

# **Gig Harbor City Council Meeting**

**October 8, 2007  
6:00 p.m.**



**AGENDA FOR  
GIG HARBOR CITY COUNCIL MEETING  
October 8, 2007 - 6:00 p.m.**

**CALL TO ORDER:**

**PLEDGE OF ALLEGIANCE:**

**SPECIAL PRESENTATION:** 2007 GH-KP Community Health Collaborative Summit – Dr. Paul Schneider

**CONSENT AGENDA:**

1. Approval of the Minutes of City Council Meeting of Sept. 24, 2007.
2. Proclamation: Domestic Violence Prevention Month.
3. Receive and File: a) Intergovernmental Affairs Committee Minutes 09/10/07; b) Joint Meeting of City Council, Planning Commission and Design Review Board Minutes 09/17/0.
4. Wetlands Review Consultant Services.
5. Eddon Boat Final Sediment Cleanup Design and Construction Documents Contract Amendment #1 – Anchor Environmental.
6. Sanitary Sewer Facilities Easement & Maintenance Agreement – Gig Harbor Peninsula Historical Society.
7. Liquor License Application for Added Privilege: Half Time Sports.
8. Special Occasion Liquor License: Knights of Columbus.
9. Approval of Payment of Bills for Oct. 8, 2007:  
Checks #55491 through #55616 in the amount of \$277,928.37.
10. Approval of Payment of Payroll for September:  
Checks #4851 through #4887 and direct deposits in the amount of \$311,740.12.

**PRESENTATION OF PROCLAMATION:** Susan Adams, Director of the Crystal Judson Family Justice Center.

**OLD BUSINESS:**

1. Second Reading of Ordinance – Amendment to Public Works Standards – Decorative Traffic Poles and Street Lights.

**NEW BUSINESS:**

1. Public Hearing and First Reading of Ordinance - Minimum Lot Size Amendments.
2. Austin Estuary Park Aquatic Lease Survey – Consultant Services Contract.
3. First Reading of Ordinance – Mayor and City Council Compensation.

**STAFF REPORT:**

1. Green Building Update - Dick Bower
2. Neighborhood Design Areas Map -Tom Dolan
3. PenMet Youth Athletic Facilities Grant

**PUBLIC COMMENT:**

**MAYOR'S REPORT / COUNCIL COMMENTS / COUNCIL COMMITTEE REPORTS:**

**ANNOUNCEMENT OF OTHER MEETINGS:**

1. GH North Traffic Options Committee – Wednesday, October 24th, at 9:00 a.m. in Community Rooms A&B.
2. Special Council Meeting with State Legislators October 15, 2007, 6 p.m.
3. Open House re: Burnham/Borgen/SR16 Roundabouts October 17, 2007 5-7 p.m.
4. Regular Council Meeting October 22, 2007, 6 p.m.
5. Special Council Meeting October 29, 2007, 6 p.m., re: Mayor's Proposed 2008 Budget and Downtown Business Plan

**ADJOURN:**

## GIG HARBOR CITY COUNCIL MEETING OF SEPTEMBER 24, 2007

**PRESENT:** Councilmembers Ekberg, Young, Franich, Dick, Payne, Kadzik and Mayor Hunter. Councilmember Conan was absent.

**CALL TO ORDER:** 6:02 p.m.

**PLEDGE OF ALLEGIANCE:**

### **CONSENT AGENDA:**

1. Approval of the Minutes of City Council Meeting of Sept. 10, 2007.
2. Receive and File: a) Parks CPI Worksession of Sept. 10, 2007
3. 45<sup>th</sup> Street Pedestrian Improvement Project – Construction Contract Authorization.
4. 45<sup>th</sup> Street Pedestrian Improvement Project – Materials Testing Services Contract.
5. Benson Street Water Main Materials – Purchase Authorization.
6. Liquor License Renewals: Fred Meyer Marketplace; Gig Harbor 76; Harvester Restaurant; QFC #864; and QFC #886.
7. Approval of Payment of Bills for Sept. 24, 2007:  
Checks #55361 through #55490 in the amount of \$582,816.34

**MOTION:** Move to approve the Consent Agenda as presented.  
**Franich / Kadzik** – unanimously approved.

### **OLD BUSINESS:**

1. Second Reading of Ordinance – Transfer of Pierce County Right-of-Way: 36<sup>th</sup> & Point Fosdick and Peacock & Borgen Blvd. Stephen Misiurak, City Engineer, presented this ordinance that would transfer right of way in two locations in which newly constructed roundabouts are partially located on county property. He read several changes made to the ordinance at the recommendation of the city attorney.

Because there is no time constraints, Council requested that a corrected version be brought to them before adoption.

**MOTION:** Move to bring the corrected ordinance back for a third reading.  
**Ekberg / Young** – unanimously approved.

2. Second Reading of Ordinance – Amending the Environmental Review (SEPA) Chapter 18.04. Jennifer Kester, Senior Planner explained that this ordinance will incorporate changes adopted by the Washington State Legislature. She recommended one change to language in 18.04.040 (A) to allow the Planning Director to designate in writing another SEPA Official in his or her absence. She answered Council questions.

**MOTION:** Move to adopt Ordinance 1103 as amended.  
**Young / Ekberg** – unanimously approved.

## **NEW BUSINESS:**

1. Resolution – Rejecting Comprehensive Plan amendment applications COMP 07-0005 and COMP 07-0006 for processing during the 2007 Comprehensive Plan annual cycle. Jennifer Kester presented this resolution based on the Council decision at the last meeting.

**MOTION:** Move to adopt Resolution No. 726 rejecting Comprehensive Plan amendment applications COMP 07-0005 and COMP 07-0006 for processing during the 2007 annual cycle.

**Young / Ekberg** – unanimously approved.

2. Public Hearing and Resolution – Six Year Transportation Improvement Plan (TIP). Steve Misiurak presented the annual update to the Six-Year TIP.

Mayor Hunter opened the public hearing at 6:17 p.m.

Karl Geist – 3709 Picnic Point Drive NW. Mr. Geist voiced his interest in the traffic plan adding that when he was chairman of the Peninsula Advisory Committee he recognized that the transportation element of the plan is inadequate. He asked how people who don't live in the city can provide input and asked for clarification on the funding, and how project priority is set. He stressed that the Wollochet Interchange Improvements listed as number 20 should be higher on the list. He said that he came to hear more information and commented on the lack of a presentation.

Mayor Hunter explained that a workshop on a more specific list of projects is scheduled at the end of this meeting and invited Mr. Geist to stay.

Staff responded to a request by Council to further explain the difference in the TIP and Transportation Element of the CIP. Steve Misiurak stressed that staff will be initiating a 20-year "look-ahead" plan, and amendments to the TIP would come from the identified deficiencies.

No one else from the public came up to speak and the public hearing closed at 6:36 p.m.

After further discussion on the Six-Year TIP, Councilmember Young recommended that that Hunt Street Underpass be eliminated from the list, as it has legal ramifications in regards to impact fees. He also agreed with comments that the TIP should be brought back after a more thorough prioritization of projects is done.

Carol Morris explained that the deadline to adopt the Six-Year TIP is July 1<sup>st</sup>, but she is unaware of any consequences of not doing so. Councilmember Payne said that he sees this as an administrative tool set by state regulations, and that he is comfortable

with passing it as is. Councilmember Franich said that he thought it should come before the Operations Committee and made the following motion.

**MOTION:** Move to refer this back to the Operations and Public Projects Committee for further review.  
Franich / Young –

Councilmembers further discussed further delays in adopting the document and the impact of the listed projects on transportation impact fees.

**RESTATED MOTION:** Move to refer this back to the Operations and Public Projects Committee for further review.  
Franich / Young – Councilmembers Dick and Franich voted yes. Councilmembers Ekberg, Young, Payne, and Kadzik voted no. The motion failed.

**MOTION:** Move to amend the Six-Year TIP to strike priority number eight, Downtown Parking Garage.  
Young / Franich –

Councilmember Franich said that this project is premature and disagreed with bonding to pay for it. He asked to see the results of the informal study and would like a definition of underground parking.

Councilmember Ekberg asked if the garage is removed, if the downtown parking lot on the exiting TIP will be completed this year. Mr. Misiurak responded that it would.

Councilmember Young said that the TIP is the first step in calculating impact fees. You determine the total dollar amount that is growth related, divide the amount on a per-trip basis and developers pay impact fees based on that amount.

Carol Morris clarified that the impact fee calculation and formula is based on a separate project list comprised of projects that are growth related and are included in the Comp Plan and/or the TIP. When the impact fee ordinance is amended, a new list of projects is also adopted.

Councilmember Young thanked her for the clarification, and withdrew his motion to amend the TIP.

Councilmember Dick said that he is still unclear of the relationship between the TIP and the Transportation Element of the CIP, and the use of real estate excise tax for funding. Rob Karlinsey said that staff tried to reconcile that anything on the CIP would be listed on the Transportation Improvement Plan. He said that the CIP is an internal document used as a tool by the Finance Director to develop the five-year forecast for budgeting purposes. He then clarified that these projects are also listed in the Capital Facilities

Element of the Comprehensive Plan so that they can be funded with real estate excise taxes.

**MOTION:** Motion to approve Resolution No. 727 adopting the Six-Year Transportation Plan.  
**Payne / Ekberg** – five voted in favor. Councilmember Young voted no.

3. First Reading of Ordinance – Amendment to Public Works Standards – Decorative Traffic Poles and Street Lights. Steve Misiurak presented this ordinance that would require decorative traffic signal poles for all new poles. He answered questions about the design. This will return for a second reading at the next meeting.

4. First Reading of Ordinance - Utility Extension - Elimination of Zoning Requirement. Carol Morris, City Attorney, presented the background on this ordinance that repeals the city's authority to impose development requirements on property outside the city limits in order to receive utilities. She explained that this is a result of a recent court case, and if the court reverses the decision, the city can readopt the requirement. She recommended that Council consider the option adopted by Marysville that property owners cannot obtain utilities unless they annex, which was upheld by the Growth Board.

Councilmember Dick asked about leaving in the requirement until the case decision is sustained. Ms. Morris recommended against this explaining that the city has held itself out as a provider of sewer and water in this area, and per the court decision, the requirements to conform to zoning and comprehensive land use plans are not valid conditions of providing water and sewer. The only way the city can deny provision of these services is for capacity related issues.

Councilmember Franich voiced concern with losing control of development standards in the UGA. Councilmember Dick asked for clarification on whether the city is required to provide utilities in the UGA and if this can be changed.

Ms. Morris responded that the city has provided service outside city limits, and the argument can be made that it is the only provider of sewer and therefore, has a duty to provide utilities.

After further discussion, Councilmembers directed the City Attorney to draft an ordinance that property owners could not obtain utilities unless they annex to the city rather than proceeding with this proposed ordinance.

5. Resolution Setting a Public Hearing Date – Prentice Avenue & Benson Street Vacation Request – Todd Block. David Brereton, Community Development Director, presented this petition to vacate a portion of Benson Street and Prentice Avenue abutting his property. This resolution sets a hearing date of October 22<sup>nd</sup>.

Councilmembers directed staff to develop a standard checklist of information, including a closer proximity GIS map, to be included with all street vacation requests.

**MOTION:** Move to adopt Resolution No. 728 as presented.  
**Young / Ekberg** – unanimously approved.

6. Resolution Setting a Public Hearing Date – Prentice Avenue & Benson Street Vacation Request – Douglas & Annette Smith. This was discussed during the previous agenda item.

**MOTION:** Move to adopt Resolution No. 729 as presented.  
**Young / Kadzik** – unanimously approved.

7. Westside Park Design Services Contract Amendment #1–Hough Beck & Baird Inc. David Brereton, Community Development Director, presented this amendment to the design contract to develop plans, specifications and bidding documents for approval by the City and IAC prior to seeking bids for construction in February of 2008.

**MOTION:** Move to authorize the amendment to the Consultant Services Contract with Hough Beck & Baird Inc. for the completion of final plans, specifications, estimate and formal bid documents for the Westside Park Project.  
**Young / Dick** – unanimously approved.

8. Development Services Process Improvements Contract Amendment. Rob Karlinsey presented this contract amendment with Kurt Latimore to help improve the seamlessness and customer service and permit tracking processes.

**MOTION:** Move to amend the Latimore Contract for review and analysis of internal development services processes.  
**Payne / Kadzik** – unanimously approved.

#### **STAFF REPORT:**

1. Burnham/Sehmel Wetlands Study. Tom Dolan, Planning Director, presented the background information on Council's request to determine the amount and location of wetlands within this annexation. He presented the proposal from Grette and Associates to perform the wetland and stream study for \$25,584.00. He asked whether Council wished to pay the entire amount, some portion, or ask the applicant to bear the entire cost of the proposed contract.

Councilmembers discussed available funds and whether this would set a precedent. Staff responded that there are funds available and clarified that the concern on the part of the applicant is due to the increase of the proposed annexation by four times at Council's request. The argument could be made that the precedent is similar participation by the city due to these circumstances.



Councilmember Franich voiced concern that this annexation is mostly residential with infrastructure costs to the city. Tom Dolan responded that the Finance Director has determined that there would be a net gain to the city.

Councilmembers commented that if the property is developed in the county, the city roads would be affected but we would not receive any impact fees. There will also be lost revenue from sales tax of construction and property tax.

Staff was asked to bring back a better map of the overview of wetland locations.

Barb Magnuson – 5801 108<sup>th</sup> Street NW. Ms. Magnuson, the applicant, clarified that a large portion of the property is zoned commercial and partially developed. The remainder east of Sehmel Drive will be developed shortly.

Councilmembers asked for a breakdown of the zoning when this returns for consideration.

**MOTION:** Move to direct staff to bring back a contract with Grette and Associates and have the city pay for the full amount.  
**Young / Payne** – five voted in favor. Councilmember Franich voted no.

2. Creating Unique Places and Enduring Legacies Conference. Rob Karlinsey reported that this upcoming conference will address cottage industry / affordable housing and recommended that a representative from Council and Staff attend. Councilmember Kadzik volunteered to attend.

3. Proposed Closure of Olympic & 56<sup>th</sup>. Steve Misiurak presented the background on the upcoming roadway improvement project, explaining that a deep sewer line and other underground structures are first part of the project to be completed. He said that due to weather, safety issues and traffic control, the contractor has requested closure of the 56<sup>th</sup> and 38<sup>th</sup> intersection for four days to be able to perform the work. The contractor will work 24 hours a day to minimize closure. In addition the contractor will be required to provide a full detour plan and outreach communication plan. Mr. Misiurak said that the Operations Committee recommended that this be brought to the full Council for discussion.

Councilmembers discussed the impact of the 4-day closure as opposed to the 16-20 days of flagged traffic and thanked staff for the thorough communication plan. Chief Davis was asked to step up patrols in the Briarwood and other neighborhoods which will become the thoroughfare for the detour.

Mr. Misiurak further addressed the signage plan for the construction work. He was asked to make sure that adjustments to the contract be made as a result of the savings due to the shortened construction time.

**PUBLIC COMMENT:** None.

## **MAYOR’S REPORT / COUNCIL COMMENTS / COUNCIL COMMITTEE REPORTS:**

Councilmember Ekberg reported that the cover of the latest version of SEA Magazine has the title “*Gig Harbor, the greatest view of the West*” with an accompanying article about our wonderful city, which is followed by an article about the opening of the new Narrows Bridge.

Councilmember Kadzik said that Council should have received an e-mail regarding a possible field trip to Bainbridge and Port Townsend to see the Mainstreet Program in place.

Councilmember Payne praised Laureen Lund, Marketing Director, for the 15 second mini-commercial on the Northwest Channel, which is very nicely done.

Councilmember Payne then asked for clarification on whether the issue of non-conformity of the tri-plexes on Harborview Drive is being addressed. Tom Dolan responded that this will be forwarded to the Planning and Building Committee for initial discussion in early October, and the intent is to bring it to Council for direct consideration after that.

## **ANNOUNCEMENT OF OTHER MEETINGS:**

1. GH North Traffic Options Committee – Wednesday, October 24th, at 9:00 a.m. in Community Rooms A & B.
2. Planning & Building Committee – Monday, October 1<sup>st</sup>, at 4:30 p.m.
3. Special Council Meeting/Downtown Business Strategy – Monday, October 1<sup>st</sup>, at 6:00 p.m.
4. City Council/Parks Commission Joint Worksession – Wednesday, October 3<sup>rd</sup>, at 6:00 p.m. in Community Rooms A&B.

**EXECUTIVE SESSION:** For the purpose of discussing pending and potential litigation per RCW 42.30.110(1)(i).

**MOTION:** Move to adjourn to Executive Session at 7:54 p.m. for the purpose of discussing pending litigation for approximately thirty minutes.  
**Franich / Young** – unanimously approved.

**MOTION:** Move to return to regular session at 8:19 p.m.  
**Franich / Young** - unanimously approved.

**MOTION:** Move to direct the City Attorney to file an appeal on the Courtyards at Skansie.

**Franich / Kadzik** - unanimously approved.

**WORKSTUDY SESSION:** Capital Improvement Plan: Transportation

Council recessed into the workstudy session at 8:20 p.m. and reconvened at 9: 37 p.m.

**ADJOURN:**

**MOTION:** Move to adjourn at 9:38 p.m.  
**Ekberg / Young** – unanimously approved.

CD recorder utilized:  
Disk #1 Tracks 1-33  
Disk #2 Tracks 1-14

---

Charles L. Hunter, Mayor

---

Molly Towslee, City Clerk

## PROCLAMATION OF THE MAYOR OF THE CITY OF GIG HARBOR

*WHEREAS, the care and protection of victims of domestic violence has traditionally been the responsibility of law enforcement agencies; and*

*WHEREAS, dedicated professionals and concerned community members have recognized the need to become involved, ensuring protection for those who may have violence imposed on them by another; and*

*WHEREAS, these victims live in fear day-to-day for their lives and the lives of their children; and*

*WHEREAS, the trauma of domestic violence includes facing emotional, financial and legal obstacles, often alone and without support; and*

*WHEREAS, the number of victims being served by our partners at the Crystal Judson Family Justice Center and the city's Domestic Violence Kiosk is increasing each month and continues to act as important tools in combating domestic violence; and*

*WHEREAS, the significant impact of domestic violence on our community and our efforts to combat this criminal activity using various methods alongside our valued partners deserves to be recognized;*

*NOW, THEREFORE, I, Charles Hunter, Mayor of the City of Gig Harbor, do proclaim the month of October, as*

### **Domestic Violence Awareness Month**

*And invite all citizens of Gig Harbor to join me in this special observance. In Witness Whereof, I have hereunto set my hand and caused the Seal of the City of Gig Harbor to be affixed this 8<sup>th</sup> day of October.*

---

Mayor, City of Gig Harbor

---

Date

## Crystal Judson Family Justice Center

### General Information

The Crystal Judson Family Justice Center (FJC) serves the needs of domestic violence victims and their children by providing comprehensive victim services in one, central, safe location. While our community has for many years had a wide variety of services for domestic violence victims, access to these services was not always easy. In a time of crisis, a victim might have traveled to a dozen or more agencies to access the services needed. As a community, we recognized the need to bring the various services providers together, under one roof, so a victim can walk through only one door and get the help they need.

The FJC is comprised of many community and government partners. A list of our partners can be found in our brochure. Clients visiting the FJC have access to victim advocacy, assistance with civil legal issues, criminal justice system advocacy, spiritual services, shelter/housing assistance, support group referrals, assistance with military issues, assistance with obtaining a protection order, and much more.

Delivery of these services is done in a warm and inviting atmosphere. The FJC is not just another government office. Our waiting area is furnished with kitchen tables and rocking chairs. A television and play area is provided for the benefit of the children visiting the center. The interview rooms are furnished with overstuffed couches and chairs. Another play area sits between the two interview rooms. Windows between the interview rooms and the play area allow the client and child to see each other, without the child having to hear what the client is discussing with the advocate.

The need for our services is great. In 2006, there were over 9500 reported domestic violence incidents made to law enforcement in our community. In the first eight months of 2007, over 800 clients with more than 300 children have visited the FJC seeking domestic violence services. In addition, the Domestic Violence Helpline has received over 1700 calls in the first six months of the year.

The FJC was created as a result of an interlocal agreement between the City of Tacoma and Pierce County. The interlocal agreement calls for the City and the County to jointly fund the FJC. The interlocal also created an Executive Board to oversee the operation of the FJC. The Executive Board is comprised of two County Council members and two City Council members and a fifth person of their choosing.

In addition to funding from the City and the County, the FJC has received financial contributions from the City of Lakewood, the Puyallup Tribe of Indians, the City of University Place, the City of Gig Harbor, and the Federal Government.



**Meeting Minutes**  
**Intergovernmental Affairs Committee**  
**September 10, 2007**

In attendance:

Councilmember Payne  
Councilmember Conan  
City Administrator Karlinsey

The meeting convened at 4:30 p.m.

The committee discussed 2008 and 2009 legislative session requests. For 2008 the City could ask for emergency funding for the sewer treatment plant expansion and outfall extension.

For 2009, the following potential requests were discussed: funding for a maritime pier, fuel dock, Donkey Creek park & road improvements, and Heritage Grants for Skansie Netshed and Eddon Boat.

As for federal requests, the committee discussed repeating this year's requests (Donkey Creek and Burnham/Hwy 16) next year.

Pre-session meetings with Gig Harbor's legislative delegation (Lantz, Seaquist, and Kilmer) are being arranged by Gordon-Thomas-Honeywell.

Karlinsey mentioned new Gordon-Thomas-Honeywell staff that will be assigned to work with the City: James McMahan and Briahna Taylor.

The committee also discussed the possibility of recognizing Congressman Dicks for the work he did to make the new Narrows Bridge a reality.

The meeting adjourned at 5:30 p.m.

**GIG HARBOR CITY COUNCIL  
PLANNING COMMISSION / DESIGN REVIEW BOARD  
JOINT WORKSESSION  
September 17, 2007 6:00 p.m. – Council Chambers**

**PRESENT:**

Councilmembers: Steve Ekberg, Derek Young, Jim Franich, Bob Dick, and Paul Kadzik and Mayor Hunter. Councilmembers Conan and Payne were absent.

Planning Commission Members: Jeanne Derebey, Jim Pasin, Chairperson Theresa Malich, Jill Guernsey, Dick Allen, and Joyce Ninen.

Design Review Board Members: Jim Pasin, Darrin Filand, Rick Gagliano, John Jernejcic, Chuck Carlson, Kae Paterson, and Jane Roth Williams.

Staff: Rob Karlinsey, Tom Dolan, and Molly Towslee. Kurt Latimore, The Latimore Company was also present.

Mayor Hunter opened the meeting at 6:03 p.m.

1. Welcome remarks and comments to the Council, Planning Commission, and DRB – Mayor Hunter. Mayor Hunter stressed the need to preserve the best of what we have in Gig Harbor. He discussed the unprecedented growth, and recommended a joint meeting of the City Council, Planning Commission and Design Review Board at least twice a year. Mayor Hunter made the following points:

- Using a “bull’s eye” approach to the Design Manual, with the downtown core as the center.
- Work hard on scale and character of development on the waterfront.
- Commercial development will increase property values and taxes. Need to keep this in balance.
- Fine tune the regulations to get the types of desired businesses.
- Health of the downtown businesses. Take 90 days to develop a vision for a downtown that attracts a mix of business and will be a draw for people.
- A meeting is scheduled on October 1st with Rod Stevens to discuss how to best accomplish the mission.
- Form a task force to develop a plan for downtown comprised of members from City Council, Design Review Board, Planning Commission, Parks Commission, Arts Commission, and members of the downtown businesses.
- How to utilize the Mainstreet Program and other tools to stimulate businesses.

Mayor Hunter finalized by complimenting Tom Dolan, Planning Director, and his staff. He announced that the 2008 Budget is in its final stages, adding that he is looking forward to making a difference in 2008. He then turned the meeting over to Tom Dolan,

Planning Director, and Kurt Latimore, The Latimore Company, to present information on plans to improve the design review process.

2. Brief overview of what the Commission and DRB have accomplished so far in 2007 in terms of Design Review Process Improvements and what's next – Kurt Latimore.

Mr. Latimore introduced the two-phase approach to improving the design review process. He explained that the improvements implemented during Phase I will allow the Design Review Process to go forward at the same time as the land use permit process. He presented the background information on how this will be done.

Tom Dolan talked about the improvements in Phase II that will provide policies for specific neighborhood design improvements. He said that eight neighborhoods around the city have been identified, and specific design goals and policies will be developed. He thanked the Planning Commission and Design Review Board, who have been working with staff on this process since February.

Mr. Dolan addressed the question of adequate public input on the neighborhoods by explaining that the Planning Commission will be holding public hearings. After further discussion, he suggested another joint work study session to allow Council the opportunity to ask questions on the map of neighborhoods before holding the public hearings. Everyone agreed that this would be a good approach.

Rick Gagliano and Teresa Malich stressed the importance of developing a vision for the city to guide discussions, which led into the next agenda item.

3. Planning Commission request for a visioning process for the entire city. Tom Dolan explained that 1990 was the last time a visioning process was done, and that several members of the DRB and PC are asking for an update.

There was discussion on the importance of having a current vision for the city before development heads down the wrong path, and whether there is time to complete a visioning process before the Phase II Comp Plan amendments go forward. It was stated that the Boards and Commissions want to know which direction in which to proceed.

Everyone agreed upon the importance of protecting the character of downtown view basin, and several comments were made that there also needs to be focus on development standards in other areas of town.

The group continued to discuss the issues of the economic feasibility of development, time constraints for a visioning process, and the difficulty in trying to obtain consensus in an ever-changing environment.



The discussion turned to the Growth Management Act, the requirement to provide buildable lands at a four unit per acre minimum, and the difficulty in having the Canterwood Development included in the Urban Growth Area calculations.

Rick Gagliano agreed that density and housing issues are among the most difficult and complicated to address. He said that trying to develop separate standards for each neighborhood would be cumbersome and very time consuming. The focus is to streamline the design review process and to reduce the volume of DRB decisions. He said that there is no perfect set of requirements to address design, scale, circulation and other issues, but it comes down to people that understand the common goal in order to steer things in the desired direction.

Councilmember Ekberg summarized that it is crucial to see which eight neighborhoods have been defined and why, then to focus on specific aspects of each. He said that the other issues such as density, topography and vegetation may be handled in a more generalized manner. Councilmember Kadzik agreed, adding that the consideration of these neighborhoods is the first step in a visioning process.

Council was asked to identify which neighborhoods, in addition to the view basin, that they would like to focus upon.

Councilmember Young stressed that a great deal of focus has been given to the downtown view basin area, and that development of the Westside is a more pressing concern. Chuck Carlson agreed, adding that the same is true of Gig Harbor North.

Jeanne Derebey said that the Planning Commission needs to move forward on defining regulations in these areas. She addressed the comments on economic feasibility by saying that developers will either find a way to comply or go elsewhere, and that it isn't the city's job to make it easier for them.

Jim Pasin agreed that a great deal of focus has been expended in the downtown view basin, but stressed the need to allow businesses such as the Post Office to expand or risk them moving out.

Mr. Gagliano talked about how the Design Review Board has to weigh, then balance the needs of an applicant and their contractor when considering a design, without being too hard core.

Mayor Hunter moved on to the next agenda item.

4. Planning Commission request for a sub-area plan for the view basin. Tom Dolan said that this was already addressed in the previous discussion. He said that a staff report on the eight identified neighborhoods would be forwarded by the October 8<sup>th</sup> Council Meeting.

5. Review of proposed efforts in 2008 for shoreline code update and affordable housing review. Mr. Dolan explained that the existing regulations are seriously out of date, and the state is requiring that they be redone. He recommended that work on this begin in 2008. He further explained that the city would be eligible to apply for state funding in 2008 to receive money in 2009, with no guarantee that funding would be approved. Mr. Dolan said that it will take approximately 18 months of dedicated work to finalize the updates.

He then passed out a copy of the Planning Commission's Work Program.

6. Review of the Planning Commission's current work program. Tom Dolan presented this program, explaining that there are over 20 potential code amendments before the Planning Commission. Coupled with the shoreline code update and affordable housing, they are going to be extremely busy. He said that he met with the Mayor and City Administrator about the possibility of appointing a blue-ribbon committee to coordinate with the Planning Commission to work on the shoreline program. That way the Planning Commission can focus on the text amendments. He said that it will be difficult for staff to meet all the expectations for this proposed work program.

Rick Gagliano suggested the creation of a group within staff to act as the long-range planning support for the boards and commissions. This group would be able to more fully prepare the materials, and it could result in shorter times for project review. The continuity would be very important.

Tom Dolan added that there are one and one-half FTEs currently working on long-range planning.

Councilmember discussed whether it would be feasible to add additional staff. Mayor Hunter said that he and the City Administrator will be sure to utilize staff to the best of their ability, and adjust staff as necessary.

Councilmember Kadzik asked if any staff members could serve on a blue-ribbon committee. Tom Dolan responded that they would have to reallocate staff resources, which would be difficult as they are all extremely busy. He added that the sewer capacity issue as well as the housing downturn may result in a slow-down in new applications, which they would monitor. He described the increased workload that resulted in the addition of another staff person.

Tom Dolan then presented the work program schedule and explained that it was for information purposes only. He said that he anticipates that the updates to the shoreline plan will end up in Tier I replacing the design review process improvement.

Councilmembers asked further questions about the need to update the shoreline plan at this time. Tom explained that Carol Morris, City Attorney, voiced concern that the

current version is inadequate. If a significant project were to come up, it would be too late if the city chooses to wait until 2009 and possible state funds.

Councilmember Young pointed out that the state is the controlling authority and the city has upland rules, and so this may not be the highest priority.

Jill Guernsey and Councilmember Bob Dick both responded that zero setbacks are the issue. Councilmember Young responded that the city just adopted the wetland buffers ordinance that addresses all of Gig Harbor Bay. He said that this was argued because the entire bay has "estuary-type" vegetation.

Councilmember Dick disagreed. There was further discussion on whether or not the code included buffering on the shoreline and Tom Dolan said that he would research the issue and report back.

Rob Karlinsey said that from a staff workload standpoint, 2008 would be better to work on updates to the shoreline plan. When the treatment plant capacity issue and traffic issues are resolved, staff will be slammed with projects.

Councilmember Young recommended adding building size limits in the DB Zone to the work program. The 6,000 s.f. limit that was put in place as a stop-gap and was never revisited leaving many areas in the DB Zone non-conforming and not allowed to remodel. At the time, there was discussion of dividing the DB Zone, and it may make sense to do it now.

It was suggested that this might fit into the Sub-area Planning for the View Basin. It is also included on the Design Review Boards list of text amendments.

Tom Dolan recommended bringing it to the Planning / Building Committee and they can recommend placement on the appropriate tier.

#### 7. Planning Commission remarks.

Dick Allen asked that a copy of a summary of the Planning Commission discussion accompany the neighborhood map when it is forwarded to the City Council.

Teresa Malich requested more public input from the people in the neighborhoods. She voiced concern with the zones outside the view basin, and the importance of letting people know about the meetings. She suggested a mass mailing prior to any public hearings. Tom Dolan said that the public hearing on the neighborhood will be scheduled for the second meeting in October.

Councilmember Franich recommended a survey to allow public input. Rob Karlinsey responded that the results from the last survey weren't high. Only 88 out of 2300 sent were returned.

Jill Guernsey commented that it sounds like a defacto decision has been made to define the neighborhoods and to work on them individually. She said that so far, this has been done without any public input, which makes her nervous. She asked for further clarification on where this is leading and what the next task will be.

Rick Gagliano responded that staff laid out a specific task to identify neighborhoods for the Design Manual. Ms. Guernsey said that she is unclear what is to be gained from this other than assistance for the Design Manual. There doesn't seem to be a consensus in opinion on where this is leading.

Chuck Carlson added that it was his understanding that it will lead to a matrix of standards for zoning.

Councilmember Ekberg said that he wants to see what has been delineated, what is contained in each neighborhood, and then review the criteria for each area one at a time. Ms. Guernsey said that so far all the direction is to define the area and talk about existing characteristics; nothing with respect to future planning.

Rick Gagliano said that once the process begins and the lines are drawn, then we can figure out why the neighborhoods are different, what's good and needs to be preserved, and what needs to be changed. He said that there is no roadmap, but this is a good process to begin looking at the other areas outside the view basin.

Councilmember Kadzik said that once we gather the information on these neighborhoods, other parameters such as zoning and business districts can be overlaid. Then a determination can be made on which direction to go with that neighborhood. He added that each time you look at elements of one neighborhood, you process all the others.

Jill Guernsey asked whether Council wanted recommendations on where we should go in the future and if we should have a vision for each neighborhood. She said that you have to set goals and there is time for next year's comp plan amendments. If Council wants them to work with the neighborhoods to develop a vision for each one, that is something they can do, but want to know if they are headed in the right direction.

Councilmember Dick said that he likes the idea, which has great promise. He said that at some point we have to make sure that the vision for each neighborhood fits with the vision for the whole city. He said that he too is concerned with getting enough public input.

Jim Pasin voiced concern with the Employment District. He asked how serious the city is with having a true Employment District and how to develop this to bring strength to the community.

Councilmember Dick said that it is an important element that hasn't had much attention devoted to it. Rick Gagliano responded that it will take the elimination of several rules to fill it because of regulations. Now, there are traffic issues.

Jill Guernsey then asked where working with these neighborhoods fits into the work load.

There was further discussion on how to proceed. Since this is new to the Council, it was recommended that now that the boundaries are set, meetings can be held and information brought back to Council in order to decide the next step to proceed.

Jeanne Derebey said that she is disappointed that Council wasn't aware of what they have been working on to date. She said that a couple of weeks ago, they were asked what they think about a visioning process to which she responded that it's too late. The city needs a visioning process for down the road, but for the problems we are facing now, it's too late and so it must be done on a neighborhood by neighborhood basis. She stressed that this doesn't mean that a 5-10 year visioning process isn't needed.

Joyce Ninen said that she thinks the Comp Plan is the vision, and that work is being done to make changes to that document. She then continued to say that special neighborhood planning groups have been very effective in other communities, admitting that trying to get people involved is difficult. She said that in order to solve the visioning problems, you have to start with the sub areas. She continued to explain that on July 19<sup>th</sup>, they held a public hearing asking for input for what people would like the city to be. Seven people spoke at this meeting and the comments were then related to the work being done. The meeting was well-publicized and so it appears that people are pretty happy with the city. Ms. Ninen suggested an e-mail survey as an easy way to communicate issues based on criteria published in either the paper or in a mailing. Ms. Ninen then continued to discuss the downtown. She said that the biggest obstacle is parking and until this is improved, the merchants will suffer.

Councilmember Franich said that an informal parking count has been done. He asked that the results be forwarded to Council and the Planning Commission.

#### 8. Design Review Board remarks.

Darrin Filand said that over the last couple of years, they have seen a lot of major developments come before the DRB, but there have been several more that have not come for review. He said that they wrestle with issues that address a small percentage of the Comp Plan goals such as the height of a retaining wall. The developers look at this with bewilderment, and it undermines the credibility of the DRB. He said that the group would like to get the big picture in order to understand things like the retention of native vegetation and natural topography so that 80% of the design is a backbone for good design. Then, they can turn loose of certain things that bog them down such as addressing the shape and color of shingles. He voiced appreciation for the participation from Jim Pasin in keeping them abreast of different zoning issues.

Rick Gagliano said that one of the most important things on their agenda is the housing and subdivision ordinance comp plan text amendments, and he would like the work plan to reflect this. Secondly, as the neighborhoods go forward he wants to make sure that they are considered as a whole with the rest of the city. He said that his last issue is that the city's core may get choked by all the development, density and additional population. We want to be very careful with traffic and how new development flows in and out of the basin.

John Jernejcic echoed the other's comments. He added that they have been working on exciting things this past year and now and we are looking at the city in a more global manner by identifying the neighborhoods and the characteristics. He said that he is looking forward to the process.

Chuck Carlson said that as we move through the process, a vision is developing. As you look at each area you determine what you do and do not like. Most of the negative comments about the Uptown Development is that it was built so close to the street. Other negative comments are about the clear cutting in Gig Harbor North area. Perhaps a vision is developing from these negative comments and from that, maybe we can create what the city wants to be. He agreed that keeping the business core in the basin is vital, and we need to do what we can to keep it going. He said that he would like to see expand the city dock to bring in more boaters during the summer season. Mr. Carlson said that he sees a problem with the zone transitions because the entire burden is upon the commercial property, using the new bank in Gig Harbor North as an example. He stressed that the responsibility should go in both directions.

Kae Paterson shared that she doesn't have a lot of background as she came into the process late. She said that she struggles with whether her vision is accurate with the town's vision and how the Growth Management Act affects it. She said that she is interested in the comment that the Canterwood Golf Course is calculated in with the density requirement. She said that she was involved in talking to boating groups about what they look for in a community. The response has been "bookstores, antiques, ice cream and bakeries," not necessarily in that order.

Jane Roth Williams said that she is enjoying taking it all in. She said that some sort of vision would help someone coming in new. She said that things do feel different in the last couple of years, and Rick's comment about "choking" has intrigued her.

#### 9. City Council remarks.

Councilmember Ekberg thanked everyone for coming to the meeting stressing that the exchange of information is extremely important. He said that he started on the Planning Commission in 1973 when Kae Paterson was there. He said that he knows what it's like to serve on a voluntary board and wonder if the Council listens. He said that they do listen, and though they may not always agree they know the amount of work that is involved. He says that Council understands the time and effort they are asking from the

boards and commissions has increased, and they really appreciate this effort. He said that they look forward to getting more frequent reports on what has transpired.

Councilmember Young echoed these comments. He said that he appreciates that the workload has increased. He stressed that Council does want to hear what the members think but if they become involved too early, it could influence the direction. He voiced appreciation for the ideas that are brought to them.

Councilmember Franich said that he had nothing to add.

Councilmember Dick thanked everyone for sharing. He said that in spite of the difficulties of a visioning process, to please continue to work towards that goal as we complete these other steps. The Comp Plan may not paint a good visual, and maybe plainer language would better articulate where we want to go.

Councilmember Kadzik also thanked everyone. He said that he knows what it's like to work hard on these committees. He said that he thinks we are headed in the right direction, and all the good things that have come to Council came externally and this is a terrific asset to have everyone here to share ideas. He said that Council wants help to know which direction to go, and then they can give direction. We rely on your work.

There were no further comments and the worksession ended at 8:17 p.m.

Respectfully submitted:

---

Molly Towslee, City Clerk



Business of the City Council
City of Gig Harbor, WA

Subject: Wetland Review Consultant Services

Proposed Council Action: Approve contract with Grette Associates LLC

Dept. Origin: Planning

Prepared by: Tom Dolan [Signature]

For Agenda of: October 8, 2007

Exhibits: Contract

Initial & Date

Concurred by Mayor:

Approved by City Administrator: [Signature] 10/2/07

Approved as to form by City Atty: [Signature] 10/2/07

Approved by Finance Director:

Approved by Department Head: [Signature] 10/1/07

Table with 4 columns: Expenditure Required, Amount Budgeted, Appropriation Required, and a final amount \$25,584.

INFORMATION / BACKGROUND

The City's critical area regulations require that a critical area review be conducted on any property proposed for annexation to the City. The City is currently processing a 380 acre annexation known as the Burnham/Sehmel Annexation. In that the scope of the annexation was expanded by the City Council, direction has been given to have the City hire a wetland consultant to perform the necessary critical area review.

FISCAL CONSIDERATION

The proposal submitted by Grette Associates is for \$25,584 to complete the necessary critical area review. Although this expenditure was not budgeted, sufficient excess funds exist within the Community Development budget to pay for the review.

BOARD OR COMMITTEE RECOMMENDATION

N/A

RECOMMENDATION / MOTION

Move to: Approve contract with Grette Associates LLC for the critical area review for the Burnham/Sehmel Annexation.



**CONSULTANT SERVICES CONTRACT  
BETWEEN THE CITY OF GIG HARBOR AND  
GRETTE ASSOCIATES**

THIS AGREEMENT is made by and between the City of Gig Harbor, a Washington municipal corporation (hereinafter the "City") and Grette Associates LLC, a limited Liability Company under the laws of the State of Washington, located and doing business at 151 South Worthen Street, Suite 101, Wenatchee, WA 98801 (hereinafter the "Consultant")

**RECITALS**

WHEREAS, under Section 18.08.090 GHMC (Wetlands – Analysis report requirements) a wetland analysis report is required with all annexation petitions; and

WHEREAS, the annexation known as the Burnham/Sehmel annexation was submitted as a 90 acre proposal; and

WHEREAS, the City Council directed the annexation applicant to significantly expand the area of the annexation to approximately 380 acres; and

WHEREAS, the City Council has determined that it is appropriate for the City to pay for the wetland report because of the requirement to expand the annexation area; and

WHEREAS, the Consultant agrees to perform the services more specifically described in the Description of Work which is attached hereto as Exhibit A – Description of Work dated September 24, 2007, and is incorporated by this reference as if fully set forth herein.

NOW, THEREFORE, in consideration of the mutual promises set forth herein, it is agreed by and between the parties as follows:

**TERMS**

**I. Description of Work**

The consultant shall perform all work as described in Exhibit "A".

**II. Payment**

A. The City shall pay the Consultant an amount as described in Exhibit "B", which shall not exceed Twenty Five Thousand, Five Hundred and Eighty

Four Dollars (\$25,584.00). This is the maximum amount to be paid under this Agreement for the work described in Exhibit "A", and shall not be exceeded without the prior written authorization of the City in the form of a negotiated and executed supplemental agreement, PROVIDED, HOWEVER, the City reserves the right to direct the Consultant's compensated services under the time frame set forth in Section IV herein before reaching the maximum amount. The parties agree that there is no minimum amount the City may be billed under this Agreement and that all fees shall be established as set forth in Exhibit B. The Consultant shall not bill the City for any services or service providers not identified in Exhibit B unless both parties agree to a modification of this contract.

B. The Consultant shall submit monthly invoices to the City after such services have been performed. The City shall pay the full amount of an invoice within forty-five (45) days of receipt. If the City objects to all or any portion of any invoice, it shall notify the Consultant of the same within fifteen (15) days from the date of receipt and shall pay that portion of the invoice not in dispute, and the parties shall immediately make every effort to settle the disputed portion.

### **III. Relationship of Parties**

The parties intend that an independent contractor-client relationship will be created by this agreement. As the Consultant is customarily engaged in an independently established trade which encompasses the specific service provided to the City hereunder, no agent, employee, representative, or sub-consultant of the Consultant shall be, or shall be deemed to be, the employee, agent, representative or sub-consultant of the City. In the performance of the work, the Consultant is an independent contractor with the ability to control and direct the performance and details of the work, the City being interested only in the results obtained under this agreement. None of the benefits provided by the City to its employees, including but not limited to, compensation, insurance, and unemployment insurance are available from the City to the employees, agents, representatives, or sub-consultants of the Consultant. The Consultant will be solely and entirely responsible for its acts and for the acts of its agents, employees, representatives, and sub-consultants during the performance of this Agreement.

The City may, during the term of this Agreement, engage other independent contractors to perform the same or similar work that the Consultant performs hereunder.

### **IV. Duration of Work**

The City and the Consultant agree that work will begin upon the execution of this contract. This Agreement shall expire on or before June 30, 2008, provided however, that the contract may be extended by agreement of both parties.

## **V. Termination**

A. Termination of Agreement. The City may terminate this Agreement, for public convenience, the Consultant's default, the Consultant's insolvency or bankruptcy, or the Consultant's assignment for the benefit of creditors, at any time prior to completion of the work described in Exhibit "A". If delivered to consultant in person, termination shall be effective immediately upon the Consultant's receipt of the City's written notice or such date stated in the City's notice, whichever is later.

B. Rights Upon Termination. In the event of termination, the City shall pay for all services satisfactorily performed by the Consultant to the effective date of termination as described on a final invoice submitted to the City, as long as the services were performed timely under the schedule in Exhibit A. Said amount shall not exceed the amount in Section II above. After termination, the City may take possession of all records and data in the Consultant's possession pertaining to this Agreement, which records and data may be used by the City without restriction. Upon termination, the City may take over the work and prosecute the same to completion, by contract or otherwise. Except in the situation where the Consultant has been terminated for public convenience, the Consultant shall be liable to the City for any additional costs incurred by the City in the completion of the Scope of Work referenced as Exhibit "A" and as modified or amended prior to termination. "Additional costs" shall mean all reasonable costs incurred by the City beyond the fees (as determined as set forth in Exhibit B) that the parties agreed would be paid to the Consultant, specified in Section II(A) above.

## **VI. Discrimination**

In the hiring of employees for the performance of work under this Agreement or any sub-contract hereunder, the Consultant, its sub-consultants, or any person acting on behalf of such Consultant or sub-consultant shall not, by reason of race, religion, color, sex, national origin, or the presence of any sensory, mental, or physical disability, discriminate against any person who is qualified and available to perform the work to which the employment relates.

## **VII. Indemnification**

The Consultant shall defend, indemnify and hold the City, its officers, officials, employees, agents and volunteers harmless from any and all claims, injuries, damages, losses or suits, including all legal costs and attorney's fees, arising out of or in connection with the performance of this Agreement, except for injuries and damages caused by the sole negligence of the City. The City's inspection or acceptance of any of the Consultant's work when completed shall not be grounds to avoid any of these covenants of indemnification.

Should a court of competent jurisdiction determine that this Agreement is subject to RCW 4.24.115, then, in the event of liability for damages arising out of bodily injury to persons or damages to property caused by or resulting from the concurrent negligence of the Consultant and the City, its officers, officials, employees, agents, and volunteers, the Consultant's liability hereunder shall be only to the extent of the Consultant's negligence.

IT IS FURTHER SPECIFICALLY AND EXPRESSLY UNDERSTOOD THAT THE INDEMNIFICATION PROVIDED HEREIN CONSTITUTES THE CONSULTANT'S WAIVER OF IMMUNITY UNDER INDUSTRIAL INSURANCE, TITLE 51 RCW, SOLELY FOR THE PURPOSES OF THIS INDEMNIFICATION. THE PARTIES FURTHER ACKNOWLEDGE THAT THEY HAVE MUTUALLY NEGOTIATED THIS WAIVER. THE CONSULTANT'S WAIVER OF IMMUNITY UNDER THIS SECTION DOES NOT INCLUDE, OR EXTEND TO, ANY CLAIMS BY THE CONSULTANT'S EMPLOYEES DIRECTLY AGAINST THE CONSULTANT.

The provisions of this section shall survive the expiration or termination of this Agreement.

### **VIII. Insurance**

A. The Consultant shall procure and maintain for the duration of the Agreement, insurance against claims for injuries to persons or damage to property which may arise from or in connection with the Consultant's own work including the work of the Consultant's agents, representatives, employees, sub-consultants or sub-contractors.

B. Before beginning work on the project described in this Agreement, the Consultant shall provide evidence, in the form of a Certificate of Insurance, of the following insurance coverage and limits (at a minimum):

1. Business auto coverage for any auto no less than a \$1,000,000 each accident limit, and
2. Commercial General Liability insurance no less than \$1,000,000 per occurrence with a \$2,000,000 aggregate. Coverage shall include, but is not limited to, contractual liability, products and completed operations, property damage, and employers liability, and
3. Professional Liability insurance with no less than \$1,000,000. All policies and coverage's shall be on a claims made basis.

C. The Consultant is responsible for the payment of any deductible or self-insured retention that is required by any of the Consultant's insurance. If the City is required to contribute to the deductible under any of the Consultant's

insurance policies, the Contractor shall reimburse the City the full amount of the deductible within 10 working days of the City's deductible payment.

D. The City of Gig Harbor shall be named as an additional insured on the Consultant's commercial general liability policy. This additional insured endorsement shall be included with evidence of insurance in the form of a Certificate of Insurance for coverage necessary in Section B. The City reserves the right to receive a certified and complete copy of all of the Consultant's insurance policies.

E. Under this agreement, the Consultant's insurance shall be considered primary in the event of a loss, damage or suit. The City's own comprehensive general liability policy will be considered excess coverage with respect to defense and indemnity of the City only and no other party. Additionally, the Consultant's commercial general liability policy must provide cross-liability coverage as could be achieved under a standard ISO separation of insured's clause.

F. The Consultant shall request from his insurer a modification of the ACORD certificate to include language that prior written notification will be given to the City of Gig Harbor at least 30-days in advance of any cancellation, suspension or material change in the Consultant's coverage.

### **IX. Exchange of Information**

The parties agree that the Consultant will notify the City of any inaccuracies in the information provided by the City as may be discovered in the process of performing work, and that the City is entitled to rely upon any information supplied by the Consultant which results as a product of this Agreement.

### **X. Ownership and Use of Records and Documents**

Original documents, drawings, designs, and reports developed under this Agreement shall belong to and become the property of the City. All written information submitted by the City to the Consultant in connection with the services performed by the Consultant under this agreement will be safeguarded by the Consultant to at least the same extent as the Consultant safeguards like information relating to its own business. If such information is publicly available or is already in Consultant's possession or known to it, or is rightfully obtained by the Consultant from third parties, the Consultant shall bear no responsibility for its disclosure, inadvertent or otherwise.

## **XI. City's Right of Inspection**

Even though the Consultant is an independent contractor with the authority to control and direct the performance and details of the work authorized under this Agreement, the work must meet the approval of the City and shall be subject to the City's general right of inspection to secure the satisfactory completion thereof. The Consultant agrees to comply with all federal, state, and municipal laws, rules, and regulations that are now effective or become applicable within the terms of this Agreement to the Consultant's performance of the work described herein, the Consultant's business, equipment, and personnel engaged in operations covered by this Agreement or accruing out of the performance of such operations.

## **XII. Consultant to Maintain Records to Support Independent Contractor Status**

On the effective date of this Agreement (or shortly thereafter), the Consultant shall comply with all federal and state laws applicable to independent contractors including, but not limited to the maintenance of a separate set of books and records that reflect all items of income and expenses of the Consultant's business, pursuant to the Revised Code of Washington (RCW) Section 51.08.195, as required to show that the services performed by the Consultant under this Agreement shall not give rise to an employer-employee relationship between the parties which is subject to RCW Title 51, Industrial Insurance.

## **XIII. Work Performed at the Consultant's Risk**

The Consultant shall take all precautions necessary and shall be responsible for the safety of its employees, agents, and sub-consultants in the performance of the work hereunder and shall utilize all protection necessary for that purpose. All work shall be done at the Consultant's own risk, and the Consultant shall be responsible for any loss of or damage to materials, tools, or other articles used or held by the Consultant for use in connection with the work.

## **XIV. Non-Waiver of Breach**

The failure of the City to insist upon strict performance of any of the covenants and agreements contained herein or to exercise any option herein conferred in one or more instances shall not be construed to be a waiver or relinquishment of said covenants, agreements, or options and the same shall be and remain in full force and effect.

## **XV. Resolution of Disputes and Governing Law**

Should any dispute, misunderstanding, or conflict arise as to the terms and conditions contained in this Agreement, the matter shall first be referred to the City Administrator and the City shall determine the term or provisions true intent or meaning. The City Administrator shall also decide all questions which may arise between the parties relative to the actual services provided or to the sufficiency of the performance hereunder.

If any dispute arises between the City and the Consultant under any of the provisions of this Agreement which cannot be resolved by the City Administrator's determination in a reasonable time, or if the Consultant does not agree with the City's decision on the disputed matter, jurisdiction of any resulting litigation shall be filed in Pierce County Superior Court, Pierce County, Washington. This agreement shall be governed by and construed in accordance with the laws of the State of Washington. The non-prevailing party in any action brought to enforce this Agreement shall pay the other parties expenses and reasonable attorney's fees.

## **XVI. Written Notice**

All communications regarding this Agreement shall be sent to the parties at the addresses listed on the signature page of this Agreement, unless notified to the contrary. Unless otherwise specified, any written notice hereunder shall become effective upon the date of mailing by registered or certified mail, and shall be deemed sufficiently given if sent to the addressee at The address stated below:

**CONSULTANT:**  
Gretty Associates, LLC  
151 South Worthen Street  
Suite 101  
Wenatchee, WA 98801

**CITY:**  
Tom Dolan  
Planning Director  
City of Gig Harbor  
3510 Grandview St.  
Gig Harbor, WA 98335  
(253) 851-6170

## **XVII. Assignment**

Any assignment of this Agreement by the Consultant without the written consent of the City shall be void. If the City shall give its consent to any assignment, this paragraph shall continue in full force and effect and no further assignment shall be made without the City's consent.

No waiver, alteration, or modification of any of the provisions of this Agreement shall be binding unless in writing and signed by a duly authorized representative of the City and the Consultant.

**XIX. Conflicts of Interest**

The City acknowledges that the Consultant is engaged in a separate practice, performing the type of work that is the subject of this Agreement, for other clients. However, a conflict of interest may arise if the Consultant is asked to perform under this Agreement by reviewing properties owned by existing or former clients. The Consultant shall notify the Planning Director if the Consultant determines that any of the properties to be reviewed under this contract are owned by existing and/or former clients of the Consultant.

**XX. Integration**

The written provisions and terms of this Agreement, together with any Exhibits attached hereto, shall supersede all prior verbal statements of any officer or other representative of the City, and such statements shall not be effective or be construed as entering into or forming a part of or altering in any manner whatsoever, this Agreement or the Agreement documents. The entire agreement between the parties with respect to the subject matter hereunder is contained in this Agreement and any Exhibits attached hereto, which may or may not have been executed prior to the execution of this Agreement. All of the above documents are hereby made a part of this Agreement and form the Agreement document as fully as if same were set forth herein. Should any language in any of the Exhibits to this Agreement conflict with any language contained in this Agreement, then this Agreement shall prevail.

**XXI. Severability.**

If any phrase, sentence or provision of this Agreement is held invalid by a court of competent jurisdiction, such invalidity shall not affect the remainder of this Agreement, and to this end the provisions of this Agreement are declared to be severable.

IN WITNESS WHEREOF, the parties have executed this Agreement on this \_\_\_\_ day of \_\_\_\_\_, 200\_\_.

CONSULTANT  
By: *Thomas B. Lietto*  
Principal

CITY OF GIG HARBOR  
By: \_\_\_\_\_  
Mayor



Notices to be sent to:

Tom Dolan  
Planning Director  
City of Gig Harbor  
3510 Grandview St.  
Gig Harbor, WA 98335  
(253) 851-6170

APPROVED AS TO FORM:

---

City Attorney

ATTEST:

---

City Clerk



STATE OF WASHINGTON )  
 ) ss.  
COUNTY OF PIERCE )

I certify that I know or have satisfactory evidence that Charles L. Hunter is the person who appeared before me, and said person acknowledged that he signed this instrument, on oath stated that he was authorized to execute the instrument and acknowledged it as the Mayor of Gig Harbor to be the free and voluntary act of such party for the uses and purposes mentioned in the instrument.

Dated: \_\_\_\_\_

\_\_\_\_\_  
\_\_\_\_\_  
(print or type name)  
NOTARY PUBLIC in and for the  
State of Washington, residing at:

My Commission expires: \_\_\_\_\_

# Exhibit A

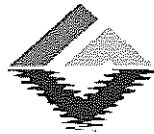

## Grette Associates<sup>LLC</sup>

ENVIRONMENTAL CONSULTANTS

**TO: Tom Dolan**  
**Planning Director**  
**City of Gig Harbor**  
**3510 Grandview Street**  
  
**Gig Harbor, WA 98335**

**Date: September 24, 2007**  
**Project Number: 207.001**  
**Project Name: City of Gig Harbor**  
**Rosedale Annexation Wetland**  
**and Stream Reconnaissance**

**SENT VIA:**

Mail  
 Fax

Hand Delivered  
 Email

**DESCRIPTION OF WORK:**

The Scope of Work detailed in the following Tasks will be limited to those properties identified in "Exhibit A" attached to the back of this contract. These properties will be referenced collectively as "Subject Property" for the purpose of this contract.

**Task 100 – GIS Analysis**

Grette Associates will perform a landscape level analysis of existing available GIS databases in order to determine the likely presence and location of wetlands and streams within the Subject Property. Analysis will include a review of soil maps, wetland mapping websites, topographic maps, and aerial imaging.

**Total Task 100** **\$2,932.00**

**Task 200 – Pierce County Public Records Review**

Grette Associates will contact Pierce County and review readily available records of existing wetland delineations, stream assessments and known wetlands and streams within the Subject Property.

**Total Task 200** **\$2,868.00**

**Task 300 – Site Verification**

Grette Associates will perform a reconnaissance level assessment of wetlands and streams within the Subject Property. This Task will be limited to visual observations conducted from public roads and right of ways. Wetlands will be identified by a predominance of hydrophytic vegetation and observable wetland hydrology. Streams location and characteristics will also be assessed. This Task does not include wetland delineation or surveying or ordinary high water mark determination.

**Total Task 300** **\$6,640.00**

2102 NORTH 30TH STREET  
TACOMA, WA 98403  
PH – 253.573.9300  
FAX – 253.573.9321

**Task 400 – Wetland Rating and Stream Typing**

Grette Associates will rate each wetland identified within the Subject Property. The ratings will be performed using Ecology's *Washington State Wetlands Rating System for Western Washington – Revised* (Hruby 2004). In cases where access is limited, ratings may be approximate. Wetland buffer widths will be determined in accordance to Gig Harbor Municipal Code 18.08.100. The typing will be performed using the WAC 22-16-030 stream type definitions. In cases where access is limited, typing may be approximate. Stream buffer widths will be determined in accordance to Gig Harbor Municipal Code 18.08.184.

**Total Task 400** **\$5,520.00**

**Task 500 – Wetland and Stream Reconnaissance Report**

Grette Associates will produce a report detailing the methods and results of the wetland and stream reconnaissance Tasks identified above. The report will include maps depicting the approximate size, shape, and location of each wetland and stream identified during this study. The report will also include a summary of findings by tax parcel.

**Total Task 500** **\$7,624.00**

**PROJECT TOTAL** **\$25,584.00**

EXHIBIT "A" (1)

SUBJECT PROPERTY

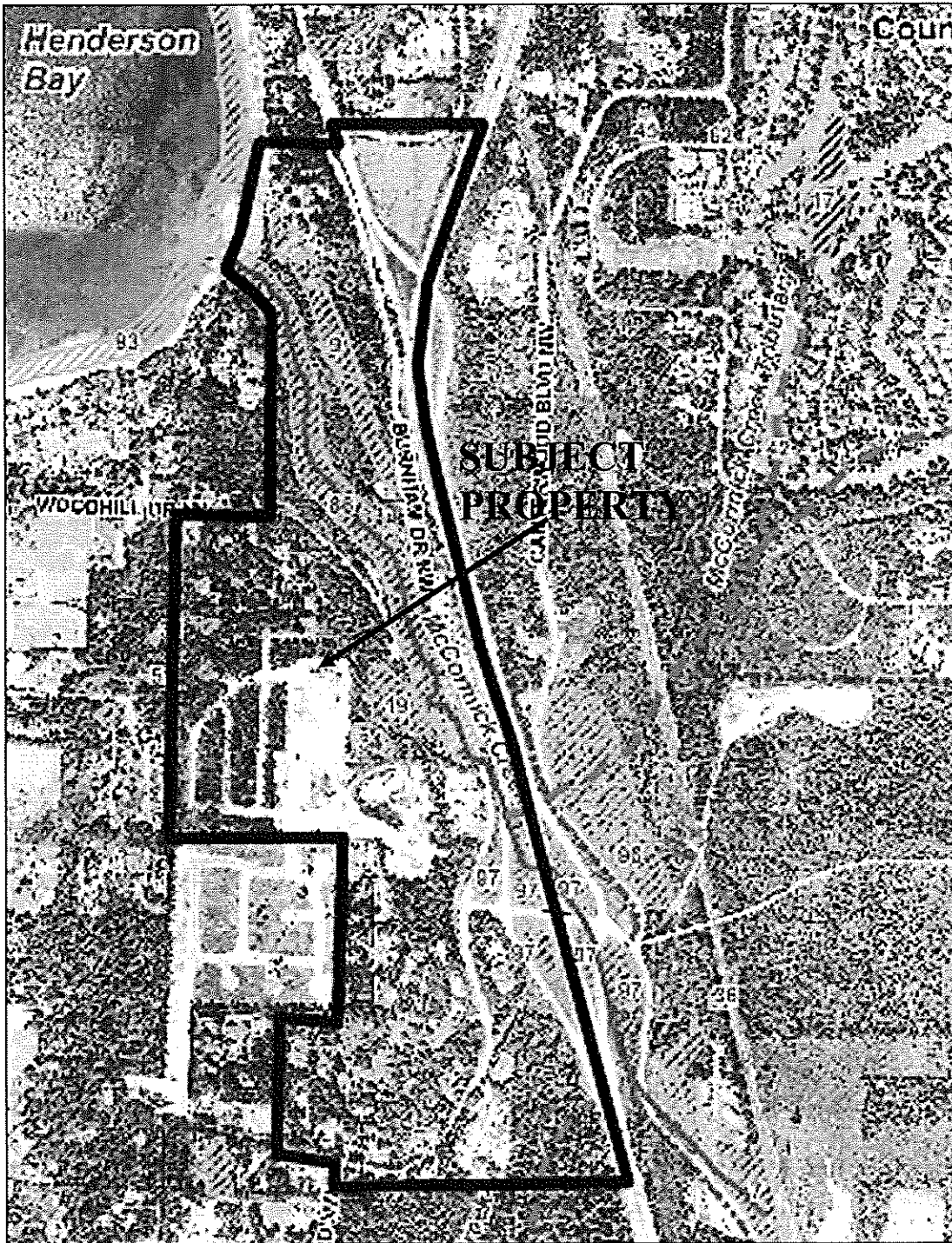

2102 NORTH 30TH STREET  
TACOMA, WA 98403  
PH - 253.573.9300  
FAX - 253.573.9321

## Exhibit "B"

### Rates

#### Grette Associates 2007 Rates

Glenn Grette	Principal	\$160.00/hr
Matthew Boyle	Principal	\$140.00/hr
	Associates	\$120.00/hr
Jim Carsner	Biologist 5	\$104.00/hr
	Biologist 4	\$95.00/hr
Larry Lehman, Scott Maharry, Ryan Walker, Melora Shelton, Jeremy Downs	Biologist 3	\$92.00/hr
Gretchen Coker	Biologist 2	\$85.00/hr
Jason Dirkse, Angela Dubois	Biologist 1	\$82.00/hr
Trina Pennington, Erin McIntyre, Tracy DeJong	Administrator	\$64.00/hr
Joel Grette	Field Assistant	\$46.00/hr
	Admin	
Danielle DeJong, Emily Goodstein	Assistant	\$46.00/hr
Subconsultants		8%
Expenses (document copying, mailing, etc)		8%
Mileage (travel from Tacoma office to Gig Harbor)		\$0.50/mile



Business of the City Council
City of Gig Harbor, WA

CA-5

Subject: Eddon Boat Final Sediment Cleanup Design and Construction Documents - Amendment #1 to Consultant Services Contract

Dept. Origin: Engineering Division

Prepared by: Stephen Misiurak, P.E. City Engineer

Proposed Council Action: Recommend that Council authorize the award and execution of the Amendment to the Consultant Services Contract with Anchor Environmental LLC for the final preparation of formal plans, specifications, engineer's estimate and bidding documents for the final sediment cleanup plan at Eddon Boat Property.

For Agenda of: October 8, 2007

Exhibits: Amendment to Consultant Services Contract

Initial & Date

Concurred by Mayor:

Approved by City Administrator: [Signature] 10/4/07

Approved as to form by City Atty: \_\_\_\_\_

Approved by Finance Director: \_\_\_\_\_

Approved by Department Head: [Signature] 10/4/07

Table with 4 columns: Expenditure Required, Amount Budgeted, Appropriation Required, See Fiscal Consideration Below. Values: \$166,341.00, \$750,000.00.

INFORMATION / BACKGROUND

This Contract Amendment provides for the final preparation of formal plans, specifications, engineer's estimate and bidding documents for the construction documents of the final sediment cleanup plan for Eddon Boat Property. Other services provided include assistance during bidding, public outreach, along with construction oversight services and inspection services during construction.

FISCAL CONSIDERATION

Funding for this expenditure will be from the Seller's escrow account. The current remaining balance available from the Seller's escrow account is \$96,541. In accordance with the terms and conditions of the purchase and sale agreement, the seller is required to replenish the escrow account when the available balance falls below \$150,000. The City in conjunction with William Joyce, legal counsel, is drafting a demand letter to the seller requesting an additional \$980,000 be deposited immediately into the account.

BOARD OR COMMITTEE RECOMMENDATION

N/A

RECOMMENDATION / MOTION

Move to: Recommend that Council authorize the award and execution of the Amendment to the Consultant Services Contract with Anchor Environmental LLC for the not-to-exceed amount of One Hundred Sixty Six Thousand Three Hundred Forty One Dollars and Zero Cents (\$166,341.00), for a revised not-to-exceed contract total of \$269,368.00.



**FIRST AMENDMENT TO CONSULTANT SERVICES CONTRACT  
BETWEEN THE CITY OF GIG HARBOR AND  
ANCHOR ENVIRONMENTAL, LLC**

THIS FIRST AMENDMENT is made to the AGREEMENT, dated July 9, 2007, by and between the City of Gig Harbor, a Washington municipal corporation (hereinafter the "City"), and Anchor Environmental, LLC, a limited liability corporation organized under the laws of the State of Washington, located and doing business at 1423 Third Avenue, Suite 300, Seattle, Washington 98101 (hereinafter the "Consultant").

**RECITALS**

WHEREAS, the City is presently engaged in the Design and Construction Documents for the Eddon Boatyard Property Final Sediment Cleanup Plan and desires that the Consultant perform services necessary to provide the following consultation services.

WHEREAS, the Consultant agreed to perform the services, and the parties executed an Agreement on July 9, 2007, (hereinafter the "Agreement"); and

WHEREAS, the existing Agreement requires the parties to execute an amendment to the Agreement in order to modify the scope of work to be performed by the Consultant, or to exceed the amount of compensation paid by the City;

NOW, THEREFORE, in consideration of the mutual promises set forth herein, it is agreed by and between the parties in this Amendment as follows:

Section 1. **Amendment to Scope of Work.** Section I of the Agreement is amended to require the Consultant to perform all work described in **Exhibit A – Scope of Work**, attached to this Amendment, which Exhibit is incorporated herein as if fully set forth.

Section 2. **Amendment to Compensation.** Section II(A) of the Agreement is amended to require the City to pay compensation to the Consultant for the work described in **Exhibit A and Table 2 dated September 27, 2007** to the Amendment in the amount of One Hundred Sixty Six Thousand Three Hundred Forty One Dollars and Zero Cents (\$166,341.00). This Amendment shall not modify any other of the remaining terms and conditions in Section II, which shall be in effect and fully enforceable.

Section 3. **Amendment to Duration of Work.** Section IV of the Agreement is amended to require the tasks described in **Exhibit A** to begin immediately upon execution of this Agreement. The parties agree that the work described in **Exhibit A** shall be completed by April 30, 2008; provided however, that additional time shall be granted by the City for excusable days or extra work.

Section 4. **Effectiveness of all Remaining Terms of Agreement.** All of the remaining terms and conditions of the Agreement between the parties shall be in effect and be fully enforceable by the parties. The Agreement shall be incorporated herein as if fully set forth, and become a part of the documents constituting the contract between the parties.

IN WITNESS WHEREOF, the parties have executed this Agreement on this \_\_\_\_\_ day of \_\_\_\_\_, 2007.

THE CITY OF GIG HARBOR

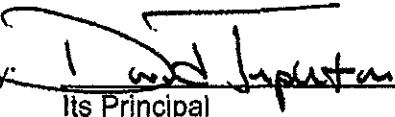
By:   
Its Principal

By: \_\_\_\_\_  
Mayor

Notices to be sent to:

CONSULTANT  
Anchor Environmental, LLC  
Attn: David Templeton, Partner  
1423 Third Avenue, Suite 300  
Seattle, Washington 98101  
(206) 287-9130

Stephen Misiurak, P.E.  
City Engineer  
City of Gig Harbor  
3510 Grandview Street  
Gig Harbor, Washington 98335  
(253) 851-6170

APPROVED AS TO FORM:

\_\_\_\_\_  
City Attorney

ATTEST:

\_\_\_\_\_  
City Clerk

STATE OF WASHINGTON     )  
  ) ss.  
COUNTY OF KING         )

I certify that I know or have satisfactory evidence that \_\_\_\_\_ is the person who appeared before me, and said person acknowledged that (he/she) signed this instrument, on oath stated that (he/she) was authorized to execute the instrument and acknowledged it as the \_\_\_\_\_ of \_\_\_\_\_ LLC, to be the free and voluntary act of such party for the uses and purposes mentioned in the instrument.

Dated: \_\_\_\_\_

\_\_\_\_\_

\_\_\_\_\_  
(print or type name)  
NOTARY PUBLIC in and for the  
State of Washington, residing at:

\_\_\_\_\_

My Commission expires: \_\_\_\_\_

STATE OF WASHINGTON        )  
  ) ss.  
COUNTY OF PIERCE         )

I certify that I know or have satisfactory evidence that Charles L. Hunter is the person who appeared before me, and said person acknowledged that he signed this instrument, on oath stated that he was authorized to execute the instrument and acknowledged it as the Mayor of Gig Harbor to be the free and voluntary act of such party for the uses and purposes mentioned in the instrument.

Dated: \_\_\_\_\_

\_\_\_\_\_

\_\_\_\_\_  
(print or type name)  
NOTARY PUBLIC in and for the  
State of Washington, residing at:

\_\_\_\_\_

My Commission expires: \_\_\_\_\_



Anchor Environmental, L.L.C.  
1423 3<sup>rd</sup> Avenue, Suite 300  
Seattle, Washington 98101  
Phone 206.287.9130  
Fax 206.287.9131

September 27, 2007

Mr. Steve Misiurak  
City of Gig Harbor  
3510 Grandview Street  
Gig Harbor, WA 98335

Mr. Bud Whitaker  
Inspectus, Inc.  
P.O. Box 401  
Gig Harbor, WA 98335

**Re: Exhibit A – Addendum No. 1 to Scope of Work for Eddon Boatyard  
Task 2 – Bid Assistance, Community Outreach, and Construction Management**

Dear Mr. Misiurak and Mr. Whitaker:

This letter presents Anchor's recommended Scope of Work and level of effort for supporting the City of Gig Harbor (the City) with bidding, community outreach, and construction management of the Eddon Boatyard sediment cleanup project. This work was defined by the City as Task 5.0 (Monitor Contractor Performance and Prepare Environmental Site Cleanup Report) under the Scope of Work detailed in its Request for Qualifications issued in early 2007 for remediation and cleanup of the Eddon Boatyard site. Anchor was awarded the contract and is currently in the process of completing Tasks 1.0 through 4.0 of the Scope of Work, including obtaining permits, community outreach, and developing design plans and specifications for the project. The proposed Scope of Work presented in this letter would encompass overall completion of the project.

Anchor submitted a Sediment Cleanup Study Report and Analysis of Brownfields Cleanup Alternatives (ABCA), collectively referred to as Revised Technical Memorandum No. 2, in February 2007 and, based on discussions with Washington State Department of Ecology

(Ecology), presented a revised preferred cleanup alternative to Ecology in March 2007. This preferred cleanup alternative was the basis of Ecology's April 17, 2007 Opinion Letter and was the basis of permit documents submitted to the various agencies in late May 2007.

A multi-agency meeting was held in April 2007 with the goal of establishing an efficient and coordinated review of the permit applications. At this meeting, a number of schedule milestones were established for implementation of the cleanup plan. The Scope of Work included herein is intended to fulfill the work requirements to meet those milestones, which are:

- Submit permit package – May 2007 (COMPLETE)
- Prepare construction package – June to September 2007 (IN PROGRESS; ON SCHEDULE)
- Permits received – November 2007 (IN PROGRESS; ON SCHEDULE)
- Contractor selection – December 2007 (PART OF CURRENT SCOPE OF WORK REQUEST)
- Construction – January to March 2008 (PART OF CURRENT SCOPE OF WORK REQUEST)

Anchor is currently developing construction plans and specifications as part of a bid-ready construction package that specifies the final design elements for the cleanup. Additional surface sediment sampling, as required by Ecology, has been conducted to inform the preparation of this construction package. An updated bathymetric survey has also been performed.

The identification and selection of the most qualified contractor at the best price will require continued close coordination with City staff to ensure that the bid process meets City requirements and results in the selection of an acceptable contractor. The contractor procurement process will be consistent with U.S. Environmental Protection Agency (EPA) Brownfields Work Plans and City procurement practices. Anchor will lead the effort for identification and selection of the most qualified contractor, in close coordination with City staff.

Once the successful bidder is under contract with the City, Anchor will provide construction management support services. These construction activities will conclude with the

development of a Final Site Cleanup Report (consistent with the requirements of the EPA Brownfields Work Plans), which will include a request to Ecology for an Opinion Letter (i.e., No Further Action letter) and negotiation of a long-term monitoring plan. We expect the Opinion Letter to include a requirement for limited monitoring of the completed cleanup.

Therefore, Anchor is hereby requesting budget authorization for Task 2 – Bid Assistance, Community Outreach, and Construction Management. Our first and immediate task under this authorization will be to initiate bid assistance for the City. The total estimated cost for Task 2 is summarized in Table 1 and described in detail in Table 2 (included as an attachment to this letter).

**Table 1  
Budget Summary**

<b>Task</b>	<b>Description</b>	<b>Current Authorization</b>	<b>Current Request</b>	<b>Duration</b>
1	Design and Construction Documents (previously authorized)	\$103,027		June to September 2007
2	Bid Assistance, Community Outreach, and Construction Management <sup>1</sup> (authorization requested)		\$166,341	December 2007 to March 2008

1 – Assumes full-time presence by an Anchor field representative during construction, as described below for Task 2. If an Anchor field representative were on site on a half-time basis, this price would decrease by \$15,000.

### **Scope of Work**

Anchor will manage the construction process in order to ensure that the project is built on schedule in accordance with the contract documents and that it meets and exceeds the expectations of the City, the interested stakeholders, and Ecology in a cost-effective manner. Anchor has a great deal of experience managing waterfront remediation projects such as this one. We have found that attention to detail, a qualifications-based contractor selection process, thorough documentation, and close observation of the contractor's work for quality and value are essential to helping the project reach its completion in a successful manner without jeopardizing grant funding reimbursement. The identification and selection of the most qualified contractor at the best price will require continued close coordination with City staff to ensure that the construction package meets City requirements and yields an acceptable bid.

The following sections describe the various subtasks that will be part of the overall work for Task 2.

***Task 2a – Bid Assistance***

Prior to completion of the construction bid package, Anchor will identify possible bidders and have informal discussions with them (as appropriate) to generate interest in competing for the work.

When the bid package is assembled, up to three Anchor representatives will attend a pre-bid meeting. This meeting will allow Anchor and the City to describe the project and show the site to potential bidders. (This meeting will not, however, function as a question-and-answer session since all answers to bidder questions will instead be issued as formal addenda, if required.) Anchor will then respond to bidder questions and will prepare addenda to the contract documents as necessary.

When bids have been received, Anchor will assist the City with evaluating the bids and selecting the most qualified contractor for the work.

***Task 2b – Community Outreach***

Anchor will assist the City with community outreach prior to the beginning of construction, including preparation of public information regarding the nature and schedule of the construction work, assistance to the City with press releases, and other tasks as necessary. We anticipate that two Anchor representatives may attend up to two public meetings related to this issue.

***Task 2c – Pre-construction Meeting***

Four representatives of the Anchor design team will attend a pre-construction meeting with the selected contractor and other key stakeholders at the site. The purpose of this meeting will be to review construction requirements, expectations, lines of communication, construction logistics, and other issues relevant to the construction process.

***Task 2d – Submittal Review***

Anchor will review required contractor submittals prior to the start of construction and throughout the construction duration. Based on our review, we will develop comments on



the submittals and will recommend to the City whether the submittal, in our opinion, should be approved, rejected, or revised and resubmitted.

***Task 2e – Field Inspection***

We recommend that Anchor stay closely involved during the construction process with the direct, on-site involvement of one of our design team members who is intimately familiar with the design rationale and who has construction phase experience. This involvement will protect the interests of the City and related parties, and will help ensure the contract documents are implemented as intended. This approach is a key facet of our construction management philosophy for complex and high-profile projects such as this one.

Our proposed field inspector for this project will be Bryan Patterson, a senior engineer who has been instrumental in the design and development of contract documents for this project, as well as other complex and high-profile sediment remediation projects in the region. (A resume for Mr. Patterson is attached.) He will observe, inspect, and record the contractor's construction operations on City-approved inspection and documentation forms to help ensure that the contractor's work is undertaken in a manner consistent with the plans, specifications, and permits. Our field inspector will remain in close communication with both the City and the contractor throughout the construction process. Such a person is typically posted at the job site on a full-time or nearly full-time basis, working out of a field office.

Although final water quality monitoring requirements have not yet been established for the project (to be established in the 401 Water Quality Certification), we anticipate that it will be necessary to perform water quality monitoring during in-water construction activities. This work will be part of our field representative's regular responsibilities on site. Our field representative will utilize a water quality meter owned by Anchor; we have assumed that a contractor-provided skiff can be used to access water monitoring locations. We do not anticipate that laboratory chemical analysis will be required as part of the water quality monitoring; therefore, it is not included as part of this Scope of Work.

As required by Ecology in their April 17, 2007 Opinion Letter, we have allowed for the collection of three surface sediment samples following dredging in the area that will not be

backfilled. These samples will be analyzed for metals, tributyltin (TBT), and polychlorinated biphenyls (PCBs).

Note that the presence of Anchor personnel at the construction site is for the purpose of providing the City a greater degree of confidence that the work will generally conform to the contract documents and that the integrity of the design concept, as reflected in the contract documents, has been implemented and preserved by the contractor. Anchor will act as the City's direct representative during construction, and in so doing will endeavor to protect all parties against defects and deficiencies in the work of the contractor. Note that Anchor shall not be responsible for safety programs in connection with the work performed by the contractor or any subcontractors.

This Scope of Work and cost estimate assumes the total duration of construction is 2 months (eight 5-day work weeks). The budget identified in this task is a level-of-effort estimate based on the hours projected, as identified in Table 2.

***Task 2f – Construction Meetings***

We have assumed attendance by up to two key Anchor team members at weekly on-site construction meetings. A third Anchor representative will attend by telephone. Again, we have assumed a total of eight weekly construction meetings for the duration of field construction work.

***Task 2g – Consultation***

Members of Anchor's design and construction team will be available to provide consultation and advice as needed to clarify the intent of the plans and specifications when questions arise during the construction of the project.

***Task 2h – Surveying***

Two surveys will be required upon completion of construction that will be used for measurement and payment as well as documenting new conditions at the site. Anchor will contract a qualified surveyor, contingency on the City's approval, to conduct the work and oversee the execution and delivery of the product. We have recently used Global Remote

Sensing (GRS) for bathymetric work and David Evans and Associates (DEA) for upland topographic work.

The first survey will be a topographic/bathymetric survey after dredging is complete. This will be used to confirm that dredging has been done to the required extent and will be used as the basis for dredging payment. The second survey will be conducted after all of the capping and upland grading is complete. This final survey will serve as the final as-built survey and will be a combination of bathymetric and upland surveying.

The City may elect to forego these surveys and instead make them part of the contractor's work requirement. However, we recommend that the City have these surveys done under its own direction to ensure the completeness and adequacy of the data, rather than relying completely on the contractor's survey results.

***Task 2i – Final Cleanup Report and Long-term Monitoring Plan***

Following the completion of construction activities, Anchor will prepare a Final Site Cleanup Report to document the successful completion of cleanup activities in accordance with project requirements and specifications. This report will include final as-built plans that depict final site grades based on a post-construction bathymetric survey (see Subtask 2h), as well as the results of inspections, monitoring, and sampling that occurred during the construction process.

A Long-term Monitoring Plan will be developed and submitted to Ecology following the completion of construction. Implementation of any required long-term monitoring, if needed, will be included in a subsequent Scope of Work.

If this Scope of Work meets the City's needs, we will assume that the City will prepare the necessary contracts. We propose to perform these tasks on a time and material basis, not to exceed a maximum cost. If the project conditions change outside the assumptions discussed in this letter, Anchor will work with the City to re-scope the necessary project elements.

Please feel free to contact me at (206) 910-4279 or [dtempleton@anchorenv.com](mailto:dtempleton@anchorenv.com) if you have any questions or would like additional information on this Scope of Work.

Sincerely,

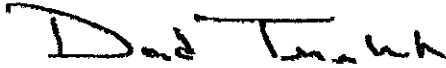

David Templeton

Partner

Anchor Environmental, L.L.C.



Michael Whelan, P.E.

Senior Project Engineer

Anchor Environmental, L.L.C.

Attachments:

Table 2 – Detailed Cost Summary

Resume – Bryan Patterson

Cc: William Joyce, Salter, Joyce, Ziker, PLLC

Table 2  
Detailed Cost Summary

**ANCHOR ENVIRONMENTAL, L.L.C.**  
**2007 PROJECT COST ESTIMATING FORM**

Proposal/Project Name: Eddon Boatyard Sediment Cleanup 040289-02  
09/27/07 City of Gig Harbor Michael Whelan

Task 2. Bid Assistance, Community Outreach, and Construction Management

Labor Categories	Billing Rate			Task 2	Total Hours	Total Dollars
Principal Engr/LA/Plan/Sci	\$ 180			237	237	\$ 42,660
Consulting Engr/LA/Plan/Sci	\$ 165			0	0	\$ -
Senior Engr/LA/Plan/Sci	\$ 145			114	114	\$ 16,530
Engr/LA/Plan/Sci	\$ 125			0	0	\$ -
Senior Staff Engr/LA/Plan/Sci	\$ 105			0	0	\$ -
Staff 2 Engr/LA/Plan/Sci	\$ 95			493	493	\$ 46,835
Staff 1 Engr/LA/Plan/Sci	\$ 85			0	0	\$ -
Senior Design/GIS/Dbase/IT	\$ 90			42	42	\$ 3,780
Design/GIS/Dbase/IT	\$ 80			0	0	\$ -
Project Assistant	\$ 70			120	120	\$ 8,400
Administrative	\$ 65			0	0	\$ -
Field Technician	\$ 65			0	0	\$ -
				0	0	\$ -
Total Hours				1,006	1,006	
Total Labor				\$ 118,205		\$ 118,205
Average Hourly Rate	\$ 118					
<b>Subconsultants</b>						
Global Remote Sensing				\$ 11,506		\$ 11,506
KPFF				\$ 3,000		\$ 3,000
David Evans and Associates				\$ 21,000		\$ 21,000
CAS Laboratories				\$ 4,000		\$ 4,000
				\$ -		\$ -
Total Cost				\$ 39,506		\$ 39,506
Markup on Subs	10.0%			\$ 3,951		\$ 3,951
<b>Reimbursables</b>						
CAD/Computer (\$/hr)	\$10.00			\$ 420		\$ 420
Mileage (\$/mile)	\$0.485			\$ 330		\$ 330
Copies (\$/copy)	\$0.10			\$ 100		\$ 100
Anchor boat (\$/day)				\$ -		\$ -
Faxes (\$/fax)	\$1.00			\$ 200		\$ 200
<b>Outside Expenses</b>						
Airfare				\$ -		\$ -
Hotel				\$ -		\$ -
Car Rental				\$ -		\$ -
Repro/Plotting				\$ 600		\$ 600
Mail/Fedex/Courier				\$ 800		\$ 800
Other Expenses				\$ 1,900		\$ 1,900
Total Cost				\$ 4,350		\$ 4,350
Outside Exp Markup	10.0%			\$ 330		\$ 330
<b>Field Equip. and Supplies Summary</b>						
				\$ -		\$ -
Markup	10.0%			\$ -		\$ -
<b>TOTAL COSTS</b>				\$ 166,341		\$ 166,341

Table 2 Detailed Cost Summary

**ANCHOR ENVIRONMENTAL, L.L.C.**  
**PROJECT COST ESTIMATING FORM**

Proposal/Project Name: Eddon Boatyard Sediment Cleanup  
 09/27/07 City of Gig Harbor

Number: 040289-02  
 Prepared by: Michael Whelan

Task 2 Total Cost	2.a Bid Assistance	\$	6,680.00	2.f Construction Meetings (8 weeks)	\$	17,620.00
\$166,341.40	2.b Community Outreach	\$	5,540.00	2.g Consultation (8 weeks)	\$	27,900.00
	2.c Pre-Construction Meeting	\$	4,634.00	2.h Surveying	\$	35,756.60
	2.d Submittal Review	\$	6,890.00	2.i Final Report and Monitoring Plan	\$	12,515.00
	2.e Field Inspection (8 weeks)	\$	48,805.80		\$	-

Billing Category	Anchor Staff	Task No. 2 Description: Bid Assistance, Community Outreach, and Construction Management										Hours or Cost
		Subtask 2.a	Subtask 2.b	Subtask 2.c	Subtask 2.d	Subtask 2.e	Subtask 2.f	Subtask 2.g	Subtask 2.h	Subtask 2.i	Subtask	
Principal Engr/LA/Plan/Sci	Berschinski, Ed	8	4	6	8	20	32	32		5		115
Principal Engr/LA/Plan/Sci	Templeton, David	8	12	6	4		12	32		10		84
Principal Engr/LA/Plan/Sci	Verduin, John					10	12	16				38
Principal Engr/LA/Plan/Sci	0											0
Senior Engr/LA/Plan/Sci	Whelan, Michael	8	4	6	8	20	24	24		20		114
Senior Engr/LA/Plan/Sci	0											0
Staff 2 Engr/LA/Plan/Sci	Page, Heather	8	16		8	14	8	8		5		67
Staff 2 Engr/LA/Plan/Sci	Patterson, Bryan	8		6	12	360				40		426
Staff 2 Engr/LA/Plan/Sci	0											0
Senior Design/GIS/Dbase/IT	Holmer, David							32		10		42
Senior Design/GIS/Dbase/IT	0											0
Project Assistant	Cohen, Brianne	8	8	12	8		24	24		12		96
Project Assistant	Goldberg, Rebecca	8			8					8		24
Project Assistant	0											0
Field Technician	Blanc, Ariel											0
Field Technician	Calleros, Jesus											0
Field Technician	Jones, Ben											0
Field Technician	Makowski, Will											0
Field Technician	Olsen, Mitch											0
Field Technician	Saugen, Steve											0
Field Technician	0											0
<b>Subconsultants</b>												<b>Cost</b>
Global Remote Sensing										\$11,506		\$11,506
KPFF								\$3,000				\$3,000
David Evans and Associates										\$21,000		\$21,000
CAS Laboratories						\$4,000						\$4,000
												\$0
<b>Reimbursables</b>												<b>Cost</b>
CAD/Computer (\$/hr)	# of hours	\$10.00						32		10		\$420
Mileage (\$/mile)	# of miles	\$0.485		400		280						\$330
Copies (\$/copy)	# of copies	\$0.10					800			200		\$100
Anchor boat (\$/day)	# of days	\$0.00										\$0
Faxes (\$/fax)	# of faxes	\$1.00						200				\$200
<b>Outside Expenses</b>												
Airfare	LS											\$0
Hotel	LS											\$0
Car Rental	LS											\$0
Repro/Plotting	LS						\$400			\$200		\$600
Mail/Fedex/Courier	LS							\$800				\$800
Other Expenses	LS				\$500	\$400	\$1,000					\$1,900



**Business of the City Council  
City of Gig Harbor, WA**

**Subject:** Sanitary Sewer Facilities Easement and Maintenance Agreement – Gig Harbor Peninsula Historical Society

**Proposed Council Action:** Approval of the Sanitary Sewer Facilities Easement and Maintenance Agreement as presented.

**Dept. Origin:** Engineering Division

**Prepared by:** Willy Hendrickson  
Engineering Technician

**For Agenda of:** October 8, 2007

**Exhibits:** Sanitary Sewer Facilities Easement and Maintenance Agreement

Initial & Date

**Concurred by Mayor:** CLH 10/3/07  
**Approved by City Administrator:** LOK 10/3/07  
**Approved as to form by City Atty:** CPM 10/3/07  
**Approved by Finance Director:** \_\_\_\_\_  
**Approved by Department Head:** Dove 10/3/07

Expenditure		Amount		Appropriation	
Required	0	Budgeted	0	Required	0

**INFORMATION / BACKGROUND**

As a condition of project approval of the Gig Harbor Peninsula Historical Society located at 4121 Harborview Drive and owned by the Gig Harbor Peninsula Historical Society, a Sanitary Sewer Facilities Maintenance Agreement is required. This will ensure that the sanitary sewer system will be constructed, operated and maintained in accordance with all applicable rules and regulations. The sanitary sewer system is located on private property and will be privately owned. The City will not be responsible for the operation and maintenance of this system. This agreement allows the City a nonexclusive right-of-entry onto those portions of the property in order to access the sanitary sewer system for inspection and monitoring of the system.

**FISCAL CONSIDERATION**

No funds will be expended for the acquisition of the described agreements.

**RECOMMENDATION / MOTION**

**Move to:** Approval of the Sanitary Sewer Facilities Easement and Maintenance Agreement as presented.

AFTER RECORDING RETURN TO:

The City of Gig Harbor  
Attn: City Clerk  
3510 Grandview St.  
Gig Harbor, WA 98335

**WASHINGTON STATE COUNTY AUDITOR/RECORDER'S INDEXING FORM**

**Document Title(s) (or transactions contained therein):**

Sanitary Sewer Facilities Easement and Maintenance Agreement

---

**Grantor(s) (Last name first, then first name and initials)**

Gig Harbor Peninsula Historical Society

---

**Grantee(s) (Last name first, then first name and initials)**

City of Gig Harbor

---

**Legal Description (abbreviated: i.e., lot, block, plat or section, township, range)**

A portion of SE1/4 of NE1/4 and the NE1/4 of SE1/4 of SEC 6, T21N, R2E

---

**Assessor's Property Tax Parcel or Account number:**

0221064001, 0221064069,  
0221064118, 4102000012, 0221064054, 0221064137

---

**Reference number(s) of documents assigned or released:** \_\_\_\_\_



**SANITARY SEWER FACILITIES EASEMENT  
AND MAINTENANCE AGREEMENT**

This Sanitary Sewer Facilities Easement and Maintenance Agreement is made this \_\_\_\_\_ day of \_\_\_\_\_, 200\_\_, by and between the City of Gig Harbor, a Washington municipal corporation (hereinafter the "City"), and Gig Harbor Peninsula Historical Society, a Non-Profit Corporation, located and doing business at 4121 Harborview Drive, Gig Harbor Washington (hereinafter the "Owner").

**RECITALS**

WHEREAS, Owner is the owner of fee title or a substantial beneficial interest in certain real property located in Gig Harbor, Washington, commonly described as Harbor History Museum located at 4121 Harborview Drive, Gig Harbor Washington, (hereinafter the "Property") and legally described in **Exhibit A-1 and A-2**, which is attached hereto and incorporated herein by this reference; and

WHEREAS, in connection with the Owner's proposed development of the Property, the City has required and the Owner has constructed a private sanitary sewer system on the Property; and

WHEREAS, such sanitary sewer system is described and shown on a construction drawing(s) prepared by the engineering firm of AHBL, dated 26 July 2007 (hereinafter the "Plans"), for the Owner's Property, a copy of which is attached hereto as **Exhibit B** and incorporated herein by this reference; and

WHEREAS, as a condition of project approval, and/or due to the nature of the development, the sanitary sewer system on the Property is private, and will not be the responsibility of and/or owned, operated and maintained by the City; and

WHEREAS, the private sanitary sewer will eventually be connected to the City's sanitary sewer system and the City desires an easement to definitively establish the permissible location of the City's access on the Property described in **Exhibit A-1 and A-2**, for the purposes described in this Agreement; and

WHEREAS, as a result of said private ownership and responsibility for operation and maintenance, including repair, rehabilitation, replacement, alterations and/or modifications, the parties have entered in to this Easement and Maintenance Agreement, in order to ensure that the sanitary sewer system will be constructed, operated and maintained in accordance with the approved Plans and all applicable rules and regulations;

NOW, THEREFORE, in consideration of the mutual agreements contained herein, as well as other good and valuable consideration, the receipt and sufficiency of which are hereby acknowledged, the Owner and the City hereby agree as follows:

**TERMS**

**Section 1. Affected Property.** The real property subject to this Agreement is legally described in **Exhibit A-1 and A-2**.

**Section 2. Definitions.** As used in this instrument:

A. The word "plat" refers to the N/A, and any other plat or plats, including short plats, covering all real property which may hereafter be made subject to the provisions of this instrument by a written instrument signed by the Owner, its successors and assigns, in accordance with this Agreement.

B. The word "lot" refers to a lot shown on any plat defined herein, but shall not include any parcel designated as a "tract" on a plat. "Lot" shall include any parcel of land that is separately subjected to this instrument without having been subdivided into two or more parcels by a plat recorded subsequent to the recording of this instrument.

C. The word "Owner" or "Owners" refers to the entity, whether an individual, corporation, joint venture or partnership which is an owner in fee simple or of a substantial beneficial interest (except for mineral estate) in all or any portion of the property in the Plat or the Property. A "substantial beneficial interest" shall include both legal and equitable interests in the Property.

D. The words "Owners' Association" refer to a nonprofit corporation which may be formed for the purpose of operating and maintaining the facilities described in **Exhibit B** on the Property, which may be independently conveyed by the Owner or its successors and assigns to an Owners' Association, and to which the Owners' Association may provide other services in order to benefit the owners of property within the plat or the Property.

**Section 3. Maintenance Obligations.** The Owner, its successors, assigns and/or owners of an after-acquired interest in the Property, hereby covenant and agree that they are jointly and severally responsible for the installation, operation, perpetual maintenance, of a sanitary sewer system on the Property, as shown on the Plans attached hereto as **Exhibit B**. The sanitary sewer system shall be operated, maintained and preserved by the Owner in accordance with the Plans and all applicable ordinances, codes, rules and regulations. The sanitary sewer system shall be preserved in conformance with the Plans until such time as all parties to this Agreement, including the City, agree in writing that the sanitary sewer system should be altered in some manner or eliminated. In the event the sanitary sewer system is eliminated as provided hereinabove, the Owner shall be relieved of operation and maintenance responsibilities. No such elimination of the sanitary sewer system will be allowed prior to the Community Development Director's written approval.

**Section 4. Notice to City.** The Owner shall obtain written approval from the Director prior to performing any alterations or modifications to the sanitary sewer system located on the Property described in Exhibit A. No part of the sanitary sewer system shall be dismantled, revised, altered or removed, except as provided hereinabove, and except as necessary for maintenance, including repair, rehabilitation, replacement, alterations, and/or other modifications.

**Section 5. Easement for Access.** The Owner hereby grants and conveys to the City a perpetual, non-exclusive easement, under, over, along, through and in the Property, as such Easement is legally described in **Exhibit C-1 and C-2**, attached hereto and incorporated herein by this reference. This Easement is granted to the City for the purpose of providing the City with ingress and egress in order to access the sanitary sewer system on the Property for inspection, and to reasonably monitor the system for performance, operational flows, defects, and/or

conformance with applicable rules and regulations. In addition, the City may use this Easement to exercise its rights as described in Section 8 herein.

**Section 6. Assignment to an Owners' Association.** In the event that an Owners' Association is formed under a Declaration of Covenants, Conditions and Restrictions which includes all of the Property in **Exhibit A**, the Owner may assign responsibility for installation and perpetual maintenance of the sanitary sewer system to such Owners' Association for so long as the Owners' Association remains in existence and upon the conditions that the Owners' Association assumes all of the obligations, liabilities, covenants and agreements of the Owner under this Agreement. Such assignment of the Owner's obligations shall be in a duly executed instrument in recordable form, and for so long as such assignment remains effective, the Owner shall have no further responsibility or liability under this Agreement.

**Section 7. Conveyances.** In the event the Owner shall convey its substantial beneficial or fee interest in any property in the Plat, any lot, or the Property, the conveying Owner shall be free from all liabilities respecting the performance of the restrictions, covenants and conditions in this Agreement; PROVIDED, HOWEVER, that the conveying Owner shall remain liable for any acts or omissions during such Owner's period of ownership of such Property.

**Section 8. Rights of the City of Gig Harbor.**

A. Execution of this Agreement shall not affect the City of Gig Harbor's present or future interest or use of any public or private sanitary sewer system. If the City determines that maintenance is required for the sanitary sewer system, and/or there is/are illegal connection(s) to or discharges into the sanitary sewer system, the Community Development Director or his/her designee shall give notice to the Owner(s) of the specific maintenance and/or changes required, and the basis for said required maintenance and/or changes. The Director shall also set a reasonable time in which the Owner(s) shall perform such work. If the maintenance required by the Director is not completed within the time set by the Director, the City may perform the required maintenance. Written notice will be sent to the Owner(s), stating the City's intention to perform such maintenance, and such work will not commence until at least five (5) days after such notice is mailed, except in situations of emergency. If, at the sole discretion of the Director, there exists an imminent or present danger to the sanitary sewer system, the City's facilities or the public health and safety, such five (5) day period will be waived, and the necessary maintenance will begin immediately.

B. In order to assure the proper maintenance of the Owner's sanitary sewer system, and to ensure there will be no damage to the City's sanitary sewer system, the City of Gig Harbor shall have the right as provided below, but not the obligation, to maintain the system, if the Owner(s) fail to do so, and such failure continues for more than five (5)-days after written notice of the failure is sent to the responsible parties. However, no notice shall be required in the event that the City of Gig Harbor determines that an emergency situation exists in which damage to person or property may result if the situation is not remedied prior to the time required for notice.

C. If the City provides notice in writing, but the Owner or Owners' Association fails or refuses to perform any maintenance or operational duties as requested by the City, the City's employees, officials, agents or representatives may enter the Property and undertake the necessary maintenance, repair or operational duties to the City's satisfaction. The City's ability

to enforce this provision is subject further to the City's right to impose materialmen's and/or laborer's liens and to foreclose upon any and all properties owned by the Owner(s).

D. If the City exercises its rights under this Section, then the Owner(s) or Owners' Association shall reimburse the City on demand for all reasonable and necessary expenses incurred incident thereto. In addition, the City is hereby given the right, power and authority acting in the name of the Owner's Association to exercise and enforce on behalf of the Association and at the Association's cost, the assessment of dues and charges for such costs and to enforce the Association's lien right for any assessments, dues and charges as herein specified. The City shall also be permitted to collect the costs of administration and enforcement through the lien attachment and collection process as is permitted under chapter 35.67 RCW, or any other applicable law.

E. In addition to or in lieu of the remedies listed in this Section, if the Owners or Owner's Association, after the written notice described in Section 8A above, fails or refuses to perform the necessary maintenance, repair, replacement or modifications, the City may enjoin, abate or remedy such breach or continuation of such breach by appropriate proceedings, and may bring an action against the violator for penalties under the Gig Harbor Municipal Code.

**Section 9. Indemnification of City.** The Owner(s) agree to defend, indemnify and hold harmless the City of Gig Harbor, its officials, officers, employees and agents, for any and all claims, demands, actions, injuries, losses, damages, costs or liabilities of any kind or amount whatsoever, whether known or unknown, foreseen or unforeseen, fixed or contingent, liquidated or unliquidated, arising from an alleged defect in the design of the sanitary sewer system as installed by the Owner(s), or arising by reason of any omission or performance under this Agreement by the Owner(s), its successors and assigns, and/or Owners' Association, of any of the obligations hereunder.

**Section 10. Rights Subject to Permits and Approvals.** The rights granted herein are subject to permits and approvals granted by the City affecting the Property subject to this Easement and Maintenance Agreement.

**Section 11. Terms Run with the Property.** The promises, conditions, covenants and restrictions contained herein shall constitute a covenant or equitable servitude, the burden and benefit of which shall run with the land and bind successive owners with equitable or legal interests in the Property. Accordingly, by its acceptance of a deed or other instrument vesting a substantial beneficial interest in all or any lot, or other portion of the Property or the Plat in such Owner, each Owner shall covenant to be bound by all the obligations incumbent upon an Owner as set forth herein, and shall be entitled to all rights and benefits accruing to an Owner hereunder. This Agreement shall be recorded in the Pierce County Assessor's Office, and shall serve as notice to holders of after-acquired interests in the Property.

**Section 12. Notice.** All notices require or permitted hereunder shall be in writing and shall either be delivered in person or sent by certified U.S. Mail, return-receipt requested, and shall be deemed delivered on the sooner of actual receipt on three (3) days after deposit in the mail, postage prepaid, addressed to the City or the Owner at the addresses set forth below:

To the City:

City Engineer  
City of Gig Harbor  
3510 Grandview Street  
Gig Harbor, WA 98335

To the Declarant:

Gig Harbor Peninsula Historical Society  
P.O. Box 744  
Gig Harbor, WA 98335

**Section 13. Severability.** Any invalidity, in whole or in part, of any provision of this Easement and Maintenance Agreement shall not affect the validity of any other provision.

**Section 14. Waiver.** No term or provision herein shall be deemed waived and no breach excused unless such waiver or consent is in writing and signed by the party claimed to have waived or consented.

**Section 15. Governing Law, Disputes.** Jurisdiction of any dispute over this Easement and Maintenance Agreement shall be solely with Pierce county Superior Court, Pierce County, Washington. This Easement and Maintenance Agreement shall be interpreted under the laws of the State of Washington. The prevailing party in any litigation arising out of this Easement and Maintenance Agreement shall be entitled to its reasonable attorneys' fees, costs, expenses and expert witness fees.

**Section 16. Integration.** This Easement and Maintenance Agreement constitutes the entire agreement between the parties on this subject matter, and supersedes all prior discussions, negotiations, and all other agreements on the same subject matter, whether oral or written.

IN WITNESS WHEREOF, the parties have caused this Easement and Maintenance Agreement be executed this \_\_\_\_ day of \_\_\_\_\_, 200\_\_.

THE CITY OF GIG HARBOR

By: \_\_\_\_\_  
Its Mayor

OWNER

By: Walter H. Smith  
Its: Pres.  
Print Name: Walter H. Smith

APPROVED AS TO FORM:

[Signature]  
\_\_\_\_\_  
City Attorney

ATTEST:

\_\_\_\_\_  
City Clerk

NOTARY BLOCK FOR A CORPORATION/PARTNERSHIP

STATE OF WASHINGTON )  
 ) ss.  
COUNTY OF Pierce )

I certify that I know or have satisfactory evidence that Walter H. Smith is the person who appeared before me, and said person acknowledged that (he/she) signed this instrument, on oath stated that (he/she) was authorized to execute the instrument and acknowledged it as the President of Gig Harbor Peninsula Historical Society, to be the free and voluntary act of such party for the uses and purposes mentioned in the instrument.

DATED: 9/19/07



Patricia McCallum  
\_\_\_\_\_  
Notary Public in and for the  
State of Washington,  
Title: Permit Coordinator  
My appointment expires: 1-22-2009

**CITY OF GIG HARBOR NOTARY BLOCK**

STATE OF WASHINGTON            )  
  ) ss.  
COUNTY OF P I E R C E        )

I certify that I know or have satisfactory evidence that Charles L. Hunter is the person who appeared before me, and said person acknowledged that he signed this instrument, on oath stated that he was authorized to execute the instrument and acknowledged it as the Mayor of Gig Harbor, to be the free and voluntary act of such party for the uses and purposes mentioned in the instrument.

DATED: \_\_\_\_\_

\_\_\_\_\_  
Notary Public in and for the  
State of Washington,  
Title: \_\_\_\_\_  
My appointment expires: \_\_\_\_\_

# EXHIBIT A-1

## PROPERTY LEGAL DESCRIPTION

PARCEL A:

ALL THAT PORTION OF THE FOLLOWING DESCRIBED TRACT, LYING EASTERLY OF THE BURNHAM-HUNT COUNTY ROAD, TO-WIT:

COMMENCING AT THE NORTHWEST CORNER OF LOT 2, SECTION 6, TOWNSHIP 21 NORTH, RANGE 2 EAST, W.M., IN PIERCE COUNTY, WASHINGTON;  
THENCE SOUTH 250 FEET MORE OR LESS TO THE CENTER OF A SMALL CREEK;  
THENCE NORTHEASTERLY ALONG CENTER OF SAID CREEK TO A POINT THAT IS 417 FEET EAST OF THE WEST LINE OF SAID LOT 2;  
THENCE NORTH 130 FEET, MORE OR LESS, TO THE NORTH LINE OF SAID LOT 2;  
THENCE WEST ALONG NORTH LINE OF SAID LOT, 417 FEET TO THE PLACE OF BEGINNING, IN PIERCE COUNTY, WASHINGTON.

TOGETHER WITH THAT PORTION OF VACATED HARBORVIEW AVENUE NORTH (BURNHAM STREET) ADJOINING, WHICH UPON VACATION, ATTACHED TO SAID PROPERTY BY OPERATION OF LAW.

PARCEL B:

BEGINNING AT NORTHWEST CORNER OF LOT 2, SECTION 6, TOWNSHIP 21 NORTH, RANGE 2 EAST OF WILLAMETTE MERIDIAN, IN PIERCE COUNTY, WASHINGTON;  
THENCE RUNNING NORTH 89°08' EAST ON NORTH SAID LOT, 417 FEET; THENCE SOUTH PARALLEL TO WEST LINE OF SAID LOT, 405.15 FEET TO NORTHEASTERLY LINE OF STATE HIGHWAY NO. 14; THENCE NORTH 46°41'20" WEST OF SAID NORTHEASTERLY LINE 68.70 FEET; THENCE NORTH PARALLEL TO WEST LINE OF SAID LOT AND ON WEST LINE OF LAND OF C.O. AUSTIN, 144.45 FEET TO TRUE POINT OF BEGINNING, THENCE SOUTH 45°10' WEST 55.09 FEET; THENCE NORTH 46°41'20" WEST 83.97 FEET; THENCE SOUTH 80°18'40" WEST 36 FEET, MORE OR LESS, TO COUNTY ROAD; THENCE ON A CURVE TO THE RIGHT RADIUS 208.75 FEET, NORTHERLY ALONG EASTERLY LINE OF SAID ROAD 43 FEET, MORE OR LESS, TO CENTER LINE OF SMALL CREEK; THENCE EASTERLY ON SAID CENTER LINE 145 FEET, MORE OR LESS, TO A POINT NORTH OF TRUE PLACE OF BEGINNING; THENCE SOUTH PARALLEL TO WEST LINE OF SAID LOT 97.92 FEET, MORE OR LESS, TO TRUE PLACE OF BEGINNING.

TOGETHER WITH THAT PORTION OF VACATED HARBORVIEW AVENUE NORTH (BURNHAM STREET) ADJOINING, WHICH UPON VACATION, ATTACHED TO SAID PROPERTY BY OPERATION OF LAW.

PARCEL C:

COMMENCING AT THE NORTHWEST CORNER OF GOVERNMENT LOT 2, SECTION 6, TOWNSHIP 21 NORTH, RANGE 2 EAST OF W.M.; THENCE NORTH 87°08'12" EAST ALONG THE NORTH LINE OF SAID LOT 417 FEET TO THE TRUE POINT OF BEGINNING OF THIS DESCRIPTION; THENCE CONTINUING NORTH 87°08'12" EAST ALONG THE NORTH LINE OF SAID LOT 138.59 FEET; THENCE SOUTH 0°38' EAST 20.13 FEET TO AN ANGLE POINT IN THE GOVERNMENT MEANDER LINE; THENCE SOUTH 15°05'25" WEST 475 FEET, MORE OR LESS, ALONG THE GOVERNMENT MEANDER LINE AND ALONG THE SEGMENT OF SAID MEANDER LINE EXTENDED TO THE NORTHERLY RIGHT-OF-WAY LINE OF STATE HIGHWAY NO. 14; THENCE NORTHWESTERLY FOLLOWING SAID RIGHT OF WAY LINE TO A POINT NORTH 87°08'12" EAST 367 FEET FROM THE WEST LINE OF SAID LOT; THENCE NORTH PARALLEL TO SAID WEST LINE OF LOT 225 FEET, MORE OR LESS, TO CENTER OF CREEK, BEING THE CREEK REFERRED TO IN CONTRACT BETWEEN J.M. GALBRAITH COMPANY AND ERVIN S. CRAIG AND WIFE, RECORDED NOVEMBER 25, 1959 UNDER RECORDING NO. 1873550, RECORDS OF SAID COUNTY; THENCE NORTH 74°30' EAST (APPROXIMATE COURSE) 51.88 FEET ALONG CENTER OF CREEK TO A POINT NORTH 87°06'12" EAST 417 FEET FROM THE WEST LINE OF SAID LOT; THENCE NORTH PARALLEL TO SAID WEST LINE OF LOT 130 FEET TO THE POINT OF BEGINNING. AND INCLUDING ANY SECOND CLASS TIDELANDS LYING WITHIN THE BOUNDARIES ABOVE DESCRIBED.

EXCEPT THEREFROM THAT PORTION CONVEYED TO HOWARD AUSTIN AND RUTH AUSTIN, HUSBAND AND WIFE, BY DEED RECORDED MARCH 7, 1968 UNDER RECORDING NO. 2229592, DESCRIBED AS FOLLOWS:

BEGINNING AT THE NORTHWEST CORNER OF GOVERNMENT LOT 2, SECTION 6, TOWNSHIP 21 NORTH, RANGE 2 EAST OF THE W.M., IN PIERCE COUNTY, WASHINGTON (SAID N.W. CORNER BEING TOWN OF BIG HARBOR UNRECORDED MONUMENT #112 STAMPED #112 AND 1/16); THENCE ALONG SAID LOT LINE, NORTH 87°08'12" EAST 470.00 FEET TO THE TRUE POINT OF BEGINNING; THENCE CONTINUING ALONG SAID LOT LINE, NORTH 87°08'12" EAST 84.79 FEET; THENCE SOUTH 0°06'55" WEST 19.88 FEET TO ANGLE POINT OF BALANCED MERIDIAN LINE; THENCE ALONG SAID MEANDER LINE SOUTH 15°05'43" WEST 6.85 FEET; THENCE SOUTH 86°22'39" WEST 39.25 FEET; THENCE NORTH 65°49'05" WEST 27.85 FEET; THENCE NORTHWESTERLY TO THE TRUE POINT OF BEGINNING.

785 Pacific Av  
Tacoma, WA 5



**EXHIBIT A-2**  
**PROPERTY LEGAL DESCRIPTION**

PARCEL D:

BEGINNING AT THE NORTHWEST CORNER OF LOT 2, SECTION 6, TOWNSHIP 21 NORTH, RANGE 2 EAST OF THE W.M., IN PIERCE COUNTY, WASHINGTON; THENCE RUNNING NORTH 89°08' EAST ON THE NORTH LINE OF SAID LOT, 417 FEET; THENCE SOUTH PARALLEL TO WEST LINE OF SAID LOT 405.15 FEET TO THE NORTHEASTERLY LINE OF FORMER STATE HIGHWAY NO. 14, NOW HARBORVIEW AVENUE WEST; THENCE NORTH 46°41'20" WEST ON SAID NORTHEASTERLY LINE 68.70 FEET TO THE TRUE POINT OF BEGINNING; THENCE NORTH 54.84 FEET; THENCE SOUTH 46°01' WEST 39.89 FEET, MORE OR LESS, TO THE NORTHEASTERLY LINE OF SAID HARBORVIEW AVENUE WEST; THENCE SOUTH 46°41'20" EAST 39.50 FEET TO THE TRUE POINT OF BEGINNING.

PARCEL E:

ALL THAT PORTION OF PROPERTY DESCRIBED IN DEED RECORDED UNDER RECORDING NO. 1670316, IN PIERCE COUNTY, WASHINGTON, LYING NORTHEASTERLY OF THE FOLLOWING DESCRIBED PROPERTY PARTITION LINE:

BEGINNING AT THE NORTHWEST CORNER OF GOVERNMENT LOT 2, SECTION 6, TOWNSHIP 21 NORTH, RANGE 2 EAST OF THE W.M., IN PIERCE COUNTY, WASHINGTON; THENCE ALONG WEST LINE OF SAID LOT 2, SOUTH 0°20'26" EAST 504.42 FEET; THENCE PARALLEL TO THE NORTH LINE OF SAID LOT 2, NORTH 87°08'12" EAST 417.00 FEET; THENCE NORTH 47°24'30" WEST 68.29 FEET TO A POINT ON THE CENTER LINE OF HARBORVIEW AVENUE WEST (A MONUMENTED STREET IN THE TOWN OF GIG HARBOR, WASH.); THENCE NORTH 0°20'26" WEST 68.29 FEET TO THE NORTHEASTERLY LINE OF SAID HARBORVIEW AVENUE WEST; THENCE CONTINUING NORTH 0°20'26" WEST 115.80 FEET TO THE TRUE POINT OF BEGINNING OF ABOVE SAID PROPERTY PARTITION LINE; THENCE ALONG PROPERTY PARTITION LINE NORTH 46°59'56" WEST TO THE NORTHWESTERLY LINE OF SAID PROPERTY DESCRIBED IN SAID DEED RECORDED UNDER RECORDING NO. 1670316.

PARCEL F:

BEGINNING AT THE NORTHWEST CORNER OF GOVERNMENT LOT 2, SECTION 6, TOWNSHIP 21 NORTH, RANGE 2 EAST OF THE W.M., IN PIERCE COUNTY, WASHINGTON (SAID NORTHWEST CORNER BEING TOWN OF GIG HARBOR, UNRECORDED MONUMENT #112-STAMPED #112 AND 1/16); THENCE NORTH 87°08'12" EAST ALONG THE NORTH LINE OF LOT 2, 309.23 FEET TO TRUE POINT OF BEGINNING ON SOUTHERLY RIGHT-OF-WAY LINE OF HARBORVIEW AVENUE NORTH; THENCE, ON LOT LINE, NORTH 87°08'12" EAST 161.57 FEET; THENCE NORTH 69°37'35" WEST 30.48 FEET; THENCE NORTH 75°08'18" WEST 27.96 FEET; THENCE NORTH 64°35' WEST 68.71 FEET TO THE SOUTHERLY RIGHT OF WAY LINE OF HARBORVIEW AVENUE NORTH; THENCE ON SAID RIGHT-OF-WAY LINE SOUTHWESTERLY TO TRUE POINT OF BEGINNING, THE ABOVE BEING PORTION OF LOT 7, BLOCK 1, EXTENSION OF THE CITY OF GIG HARBOR, PIERCE COUNTY, WASHINGTON, ACCORDING TO PLAT RECORDED IN VOLUME 6 OF PLATS AT PAGE 74, IN PIERCE COUNTY, WASHINGTON.

EXCEPT THAT PORTION CONVEYED TO THE TOWN OF GIG HARBOR BY INSTRUMENT RECORDED UNDER RECORDING NO. 1520257.

---

# EXHIBIT B

CONTRACTOR IS SUBJECT TO A CONTRACTOR PROPOSED DESIGN BY A FIRE PROTECTION ENGINEER, AND AS SUCH, THE FINAL DESIGN OF THE FIRE PROTECTION SYSTEM MAY DEVIATE FROM THE SYSTEM SHOWN. THE FIRE PROTECTION SYSTEM AS SHOWN FROM THE MAIN LINE TO THE CONNECTION AT THE BUILDING SPRAWLER IS INTENDED FOR LOCATION OF THE FIRE HYDRANTS AND FIRE DEPARTMENT CONNECTION ONLY. CONTRACTOR'S BID SHALL REFLECT THE CONNECTIONS OF THE FIRE PROTECTION ENGINEER'S DESIGN. CONTRACTOR SHALL COMPLY WITH ALL NATIONAL FIRE PROTECTION ASSOCIATION REQUIREMENTS AS SET FORTH BY NFPA 17, ITS AMENDMENTS, AND LOCAL REQUIREMENTS, INCLUDING BUT NOT LIMITED TO ACQUISITION OF ALL PERMITS.

ONLY A FIRE SPRINKLER SYSTEM, A SEPARATE DETAILED PLAN MUST BE SUBMITTED AND APPROVED BY THE FIRE MARSHAL PRIOR TO INSTALLATION.

NOTE: FUTURE EASEMENT FOR DORSEY CREEK CONSERVATION TO BE INCORPORATED WITH THE CITY OF GUNNISON UPON COMPLETION OF THE RESTORATION DESIGN.

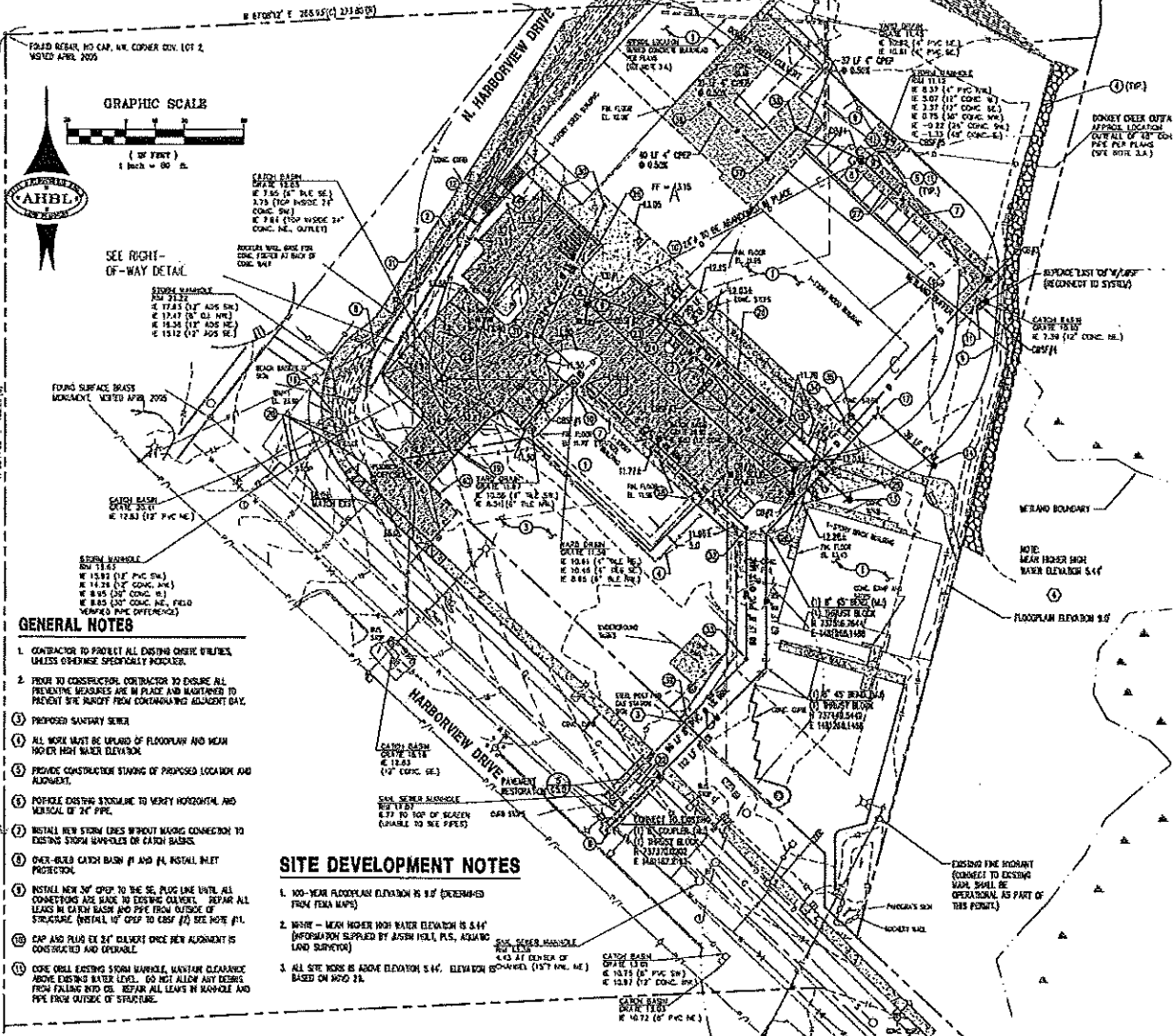

### GENERAL NOTES

1. CONTRACTOR TO PROTECT ALL EXISTING UTILITY UTILITIES UNLESS OTHERWISE SPECIFICALLY NOTED.
2. PRIOR TO CONSTRUCTION, CONTRACTOR TO ENSURE ALL FLOODING REGULATIONS ARE IN PLACE AND ADHERED TO PREVENT THE PROJECT FROM CONTAMINATING ADJACENT BAY.
3. PROPOSED SANITARY SEWER
4. ALL WORK MUST BE UPWARD OF FLOODPLAIN AND MEAN HIGHER HIGH WATER ELEVATION.
5. PROVIDE CONSTRUCTION STAKING OF PROPOSED LOCATION AND ALIGNMENT.
6. REPAIR EXISTING STRUCTURE TO VERIFY HORIZONTAL AND VERTICAL OF PIPE.
7. INSTALL NEW STORM LINES WITHOUT MAKING CONNECTION TO EXISTING STORM MANHOLES OR CATCH BASINS.
8. ONE-ENDED CATCH BASIN #1 AND #4, INSTALL INLET PROTECTION.
9. INSTALL NEW 3" CPVC TO THE SE. PUC LINE UNTIL ALL CONNECTIONS ARE MADE TO EXISTING CLEANOUT. REPAIR ALL LEAKS IN CATCH BASIN AND PIPE FROM OUTSIDE OF STRUCTURE. INSTALL 1" CPVC TO CATCH #2. SEE NOTE #11.
10. CAP AND PLUG EX. 2" CLEANOUT ONCE NEW ALIGNMENT IS CONSTRUCTED AND OPERABLE.
11. COPE OVER ALL EXISTING STORM MANHOLE, MAINTAIN CLEANOUTS ABOVE EXISTING WATER LEVEL. DO NOT ALLOW ANY DEBRIS FROM FALLING INTO CO. REPAIR ALL LEAKS IN MANHOLE AND PIPE FROM OUTSIDE OF STRUCTURE.

### SITE DEVELOPMENT NOTES

1. 100-YEAR FLOODPLAIN ELEVATION IS 5.17' (DETERMINED FROM FEMA MAPS)
2. MHHW - MEAN HIGHER HIGH WATER ELEVATION IS 5.44' (INFORMATION SUPPLIED BY ASSEN HULL, PLS, ASSESSING LAND SURVEYOR)
3. ALL SITE WORK IS ABOVE ELEVATION 5.44'. ELEVATION IS BASED ON MDD 21.

**EXHIBIT C-1**  
**EASEMENT LEGAL DESCRIPTION**

PARCEL A:

ALL THAT PORTION OF THE FOLLOWING DESCRIBED TRACT, LYING EASTERLY OF THE BURNHAM-HUNT COUNTY ROAD, TO-WIT:

COMMENCING AT THE NORTHWEST CORNER OF LOT 2, SECTION 6, TOWNSHIP 21 NORTH, RANGE 2 EAST, W.M., IN PIERCE COUNTY, WASHINGTON;  
THENCE SOUTH 250 FEET MORE OR LESS TO THE CENTER OF A SMALL CREEK;  
THENCE NORTHEASTERLY ALONG CENTER OF SAID CREEK TO A POINT THAT IS 417 FEET EAST OF THE WEST LINE OF SAID LOT 2;  
THENCE NORTH 130 FEET, MORE OR LESS, TO THE NORTH LINE OF SAID LOT 2;  
THENCE WEST ALONG NORTH LINE OF SAID LOT, 417 FEET TO THE PLACE OF BEGINNING, IN PIERCE COUNTY, WASHINGTON.

TOGETHER WITH THAT PORTION OF VACATED HARBORVIEW AVENUE NORTH (BURNHAM STREET) ADJOINING, WHICH UPON VACATION, ATTACHED TO SAID PROPERTY BY OPERATION OF LAW.

PARCEL B:

BEGINNING AT NORTHWEST CORNER OF LOT 2, SECTION 6, TOWNSHIP 21 NORTH, RANGE 2 EAST OF WILLAMETTE MERIDIAN, IN PIERCE COUNTY, WASHINGTON;  
THENCE RUNNING NORTH 89°08' EAST ON NORTH SAID LOT, 417 FEET; THENCE SOUTH PARALLEL TO WEST LINE OF SAID LOT, 405.15 FEET TO NORTHEASTERLY LINE OF STATE HIGHWAY NO. 14; THENCE NORTH 46°41'20" WEST OF SAID NORTHEASTERLY LINE 68.70 FEET; THENCE NORTH PARALLEL TO WEST LINE OF SAID LOT AND ON WEST LINE OF LAND OF C.O. AUSTIN, 144.45 FEET TO TRUE POINT OF BEGINNING, THENCE SOUTH 45°10' WEST 55.09 FEET; THENCE NORTH 46°41'20" WEST 83.97 FEET; THENCE SOUTH 80°18'40" WEST 36 FEET, MORE OR LESS, TO COUNTY ROAD; THENCE ON A CURVE TO THE RIGHT RADIUS 208.75 FEET, NORTHERLY ALONG EASTERLY LINE OF SAID ROAD 43 FEET, MORE OR LESS, TO CENTER LINE OF SMALL CREEK; THENCE EASTERLY ON SAID CENTER LINE 145 FEET, MORE OR LESS, TO A POINT NORTH OF TRUE PLACE OF BEGINNING; THENCE SOUTH PARALLEL TO WEST LINE OF SAID LOT 97.92 FEET, MORE OR LESS, TO TRUE PLACE OF BEGINNING.

TOGETHER WITH THAT PORTION OF VACATED HARBORVIEW AVENUE NORTH (BURNHAM STREET) ADJOINING, WHICH UPON VACATION, ATTACHED TO SAID PROPERTY BY OPERATION OF LAW.

PARCEL C:

COMMENCING AT THE NORTHWEST CORNER OF GOVERNMENT LOT 2, SECTION 6, TOWNSHIP 21 NORTH, RANGE 2 EAST OF W.M.; THENCE NORTH 87°08'12" EAST ALONG THE NORTH LINE OF SAID LOT 417 FEET TO THE TRUE POINT OF BEGINNING OF THIS DESCRIPTION; THENCE CONTINUING NORTH 87°08'12" EAST ALONG THE NORTH LINE OF SAID LOT 138.59 FEET; THENCE SOUTH 0°38' EAST 20.13 FEET TO AN ANGLE POINT IN THE GOVERNMENT MEANDER LINE; THENCE SOUTH 15°05'25" WEST 475 FEET, MORE OR LESS, ALONG THE GOVERNMENT MEANDER LINE AND ALONG THE SEGMENT OF SAID MEANDER LINE EXTENDED TO THE NORTHERLY RIGHT-OF-WAY LINE OF STATE HIGHWAY NO. 14; THENCE NORTHWESTERLY FOLLOWING SAID RIGHT OF WAY LINE TO A POINT NORTH 87°08'12" EAST 367 FEET FROM THE WEST LINE OF SAID LOT; THENCE NORTH PARALLEL TO SAID WEST LINE OF LOT 225 FEET, MORE OR LESS, TO CENTER OF CREEK, BEING THE CREEK REFERRED TO IN CONTRACT BETWEEN J.M. GALBRAITH COMPANY AND ERVIN S. CRAIG AND WIFE, RECORDED NOVEMBER 25, 1959 UNDER RECORDING NO. 1873550, RECORDS OF SAID COUNTY; THENCE NORTH 74°30' EAST (APPROXIMATE COURSE) 51.88 FEET ALONG CENTER OF CREEK TO A POINT NORTH 87°06'12" EAST 417 FEET FROM THE WEST LINE OF SAID LOT; THENCE NORTH PARALLEL TO SAID WEST LINE OF LOT 130 FEET TO THE POINT OF BEGINNING, AND INCLUDING ANY SECOND CLASS TIDELANDS LYING WITHIN THE BOUNDARIES ABOVE DESCRIBED.

EXCEPT THEREFROM THAT PORTION CONVEYED TO HOWARD AUSTIN AND RUTH AUSTIN, HUSBAND AND WIFE, BY DEED RECORDED MARCH 7, 1968 UNDER RECORDING NO. 2229592, DESCRIBED AS FOLLOWS:

BEGINNING AT THE NORTHWEST CORNER OF GOVERNMENT LOT 2, SECTION 6, TOWNSHIP 21 NORTH, RANGE 2 EAST OF THE W.M., IN PIERCE COUNTY, WASHINGTON (SAID N.W. CORNER BEING TOWN OF BIG HARBOR UNRECORDED MONUMENT #112 STAMPED #112 AND 1/16); THENCE ALONG SAID LOT LINE, NORTH 87°08'12" EAST 470.00 FEET TO THE TRUE POINT OF BEGINNING; THENCE CONTINUING ALONG SAID LOT LINE, NORTH 87°08'12" EAST 84.79 FEET; THENCE SOUTH 0°06'55" WEST 19.88 FEET TO ANGLE POINT OF BALANCED MERIDIAN LINE; THENCE ALONG SAID MEANDER LINE SOUTH 15°05'43" WEST 6.85 FEET; THENCE SOUTH 86°22'39" WEST 39.25 FEET; THENCE NORTH 65°49'05" WEST 27.85 FEET; THENCE NORTHWESTERLY TO THE TRUE POINT OF BEGINNING.

705 Pacific Av  
Tacoma, WA 5

**EXHIBIT C-1**  
**EASEMENT LEGAL DESCRIPTION**

PARCEL D:

BEGINNING AT THE NORTHWEST CORNER OF LOT 2, SECTION 6, TOWNSHIP 21 NORTH, RANGE 2 EAST OF THE W.M., IN PIERCE COUNTY, WASHINGTON; THENCE RUNNING NORTH 89°08' EAST ON THE NORTH LINE OF SAID LOT, 417 FEET; THENCE SOUTH PARALLEL TO WEST LINE OF SAID LOT 405.15 FEET TO THE NORTHEASTERLY LINE OF FORMER STATE HIGHWAY NO. 14, NOW HARBORVIEW AVENUE WEST; THENCE NORTH 46°41'20" WEST ON SAID NORTHEASTERLY LINE 68.70 FEET TO THE TRUE POINT OF BEGINNING; THENCE NORTH 54.84 FEET; THENCE SOUTH 46°01' WEST 39.89 FEET, MORE OR LESS, TO THE NORTHEASTERLY LINE OF SAID HARBORVIEW AVENUE WEST; THENCE SOUTH 46°41'20" EAST 39.50 FEET TO THE TRUE POINT OF BEGINNING.

PARCEL E:

ALL THAT PORTION OF PROPERTY DESCRIBED IN DEED RECORDED UNDER RECORDING NO. 1670316, IN PIERCE COUNTY, WASHINGTON, LYING NORTHEASTERLY OF THE FOLLOWING DESCRIBED PROPERTY PARTITION LINE:

BEGINNING AT THE NORTHWEST CORNER OF GOVERNMENT LOT 2, SECTION 6, TOWNSHIP 21 NORTH, RANGE 2 EAST OF THE W.M., IN PIERCE COUNTY, WASHINGTON; THENCE ALONG WEST LINE OF SAID LOT 2, SOUTH 0°20'26" EAST 504.42 FEET; THENCE PARALLEL TO THE NORTH LINE OF SAID LOT 2, NORTH 87°08'12" EAST 417.00 FEET; THENCE NORTH 47°24'30" WEST 68.29 FEET TO A POINT ON THE CENTER LINE OF HARBORVIEW AVENUE WEST (A MONUMENTED STREET IN THE TOWN OF GIG HARBOR, WASH.); THENCE NORTH 0°20'26" WEST 68.29 FEET TO THE NORTHEASTERLY LINE OF SAID HARBORVIEW AVENUE WEST; THENCE CONTINUING NORTH 0°20'26" WEST 115.60 FEET TO THE TRUE POINT OF BEGINNING OF ABOVE SAID PROPERTY PARTITION LINE; THENCE ALONG PROPERTY PARTITION LINE NORTH 46°59'56" WEST TO THE NORTHWESTERLY LINE OF SAID PROPERTY DESCRIBED IN SAID DEED RECORDED UNDER RECORDING NO. 1670316.

PARCEL F:

BEGINNING AT THE NORTHWEST CORNER OF GOVERNMENT LOT 2, SECTION 6, TOWNSHIP 21 NORTH, RANGE 2 EAST OF THE W.M., IN PIERCE COUNTY, WASHINGTON (SAID NORTHWEST CORNER BEING TOWN OF GIG HARBOR, UNRECORDED MONUMENT #112-STAMPED #112 AND 1/16); THENCE NORTH 87°08'12" EAST ALONG THE NORTH LINE OF LOT 2, 309.23 FEET TO TRUE POINT OF BEGINNING ON SOUTHERLY RIGHT-OF-WAY LINE OF HARBORVIEW AVENUE NORTH; THENCE, ON LOT LINE, NORTH 87°08'12" EAST 161.57 FEET; THENCE NORTH 69°37'35" WEST 30.48 FEET; THENCE NORTH 75°08'18" WEST 27.98 FEET; THENCE NORTH 64°35' WEST 68.71 FEET TO THE SOUTHERLY RIGHT OF WAY LINE OF HARBORVIEW AVENUE NORTH; THENCE ON SAID RIGHT-OF-WAY LINE SOUTHWESTERLY TO TRUE POINT OF BEGINNING, THE ABOVE BEING PORTION OF LOT 7, BLOCK 1, EXTENSION OF THE CITY OF GIG HARBOR, PIERCE COUNTY, WASHINGTON, ACCORDING TO PLAT RECORDED IN VOLUME 6 OF PLATS AT PAGE 74, IN PIERCE COUNTY, WASHINGTON.

EXCEPT THAT PORTION CONVEYED TO THE TOWN OF GIG HARBOR BY INSTRUMENT RECORDED UNDER RECORDING NO. 1520257.

---



NOTICE OF LIQUOR LICENSE APPLICATION

RECEIVED
SEP 25 2007
CITY OF GIG HARBOR

WASHINGTON STATE LIQUOR CONTROL BOARD
License Division - 3000 Pacific, P.O. Box 43075
Olympia, WA 98504-3075
Customer Service: (360) 664-1600
Fax: (360) 753-2710
Website: www.liq.wa.gov
DATE: 9/21/07

TO: MOLLY TOWSLEE, CITY CLERK

RE: APPLICATION FOR ADDED PRIVILEGE

UBI: 602-584-998-001-0001
License: 073240 - 1U County: 27
Tradename: HALF TIME SPORTS
Loc Addr: 5114 PT FOSDICK DR NW # J&K
GIG HARBOR WA 98335-1717
Mail Addr: 11824 70TH AVE NW
GIG HARBOR WA 98332-8503
Phone No.: 253-851-9638

APPLICANTS:
HALFTIME SPORTS, LLC
HUGHES, COREY D
1969-02-01
VANDEGRIFT, BERNICE A
1958-06-16

Privileges Upon Approval:
SPIRITS/BR/WN REST LOUNGE -
KEGS TO GO

As required by RCW 66.24.010(8), the Liquor Control Board is notifying you that the above has applied for a liquor license. You have 20 days from the date of this notice to give your input on this application. If we do not receive this notice back within 20 days, we will assume you have no objection to the issuance of the license. If you need additional time to respond, you must submit a written request for an extension of up to 20 days, with the reason(s) you need more time. If you need information on SSN, contact our CHRI Desk at (360) 664-1724.

- 1. Do you approve of applicant ?
2. Do you approve of location ?
3. If you disapprove and the Board contemplates issuing a license, do you wish to request an adjudicative hearing before final action is taken?
4. If you disapprove, per RCW 66.24.010(8) you MUST attach a letter to the Board detailing the reason(s) for the objection and a statement of all facts on which your objection(s) are based.

DATE

SIGNATURE OF MAYOR,CITY MANAGER,COUNTY COMMISSIONERS OR DESIGNEE

FILE COPY

WASHINGTON STATE LIQUOR CONTROL BOARD-License Services  
1025 E Union - P O Box 43075  
Olympia WA 98504-3075

TO: MAYOR OF GIG HARBOR

September 20, 2007

SPECIAL OCCASION # 090826

KNIGHTS OF COLUMBUS  
3510 ROSEDALE ST NW  
GIG HARBOR WA 98335

DATE: NOVEMBER 4, 2007

TIME: NOON TO 7 PM

PLACE: ST. NICHOLAS CHURCH, 3510 ROSEDALE ST NW, GIG HARBOR

CONTACT: JACK MICHEL

253-857-9123

**SPECIAL OCCASION LICENSES**

- \*  License to sell beer on a specified date for consumption at specific place.
- \*  License to sell wine on a specific date for consumption at a specific place.
- \*  Beer/Wine in unopened bottle or package in limited quantity for off premises consumption.
- \*  Spirituous liquor by the individual glass for consumption at a specific place.

If return of this notice is not received in this office within 20 days from the above date, we will assume you have no objection to the issuance of the license. If additional time is required please advise.

1. Do you approve of applicant? YES\_\_ NO\_\_
2. Do you approve of location? YES\_\_ NO\_\_
3. If you disapprove and the Board contemplates issuing a license, do you want a hearing before final action is taken? YES\_\_ NO\_\_

<b>OPTIONAL CHECK LIST</b>	<b>EXPLANATION</b>	
LAW ENFORCEMENT	_____	YES__ NO__
HEALTH & SANITATION	_____	YES__ NO__
FIRE, BUILDING, ZONING	_____	YES__ NO__
OTHER:	_____	YES__ NO__

If you have indicated disapproval of the applicant, location or both, please submit a statement of all facts upon which such objections are based.

DATE SIGNATURE OF MAYOR, CITY MANAGER, COUNTY COMMISSIONERS OR DESIGNEE



Business of the City Council
City of Gig Harbor, WA

Subject: Second Reading of Ordinance-
Amendment to Public Works Standards
-Decorative Traffic Signal Poles and
Street Lights

Proposed Council Action: Adopt Ordinance
Of an Amendment to the Public Works
Standards Regarding Traffic Signal Poles and
Street Lights.

Dept. Origin: Engineering Division

Prepared by: Stephen Misiurak, P.E.
City Engineer

For Agenda of: October 8, 2007

Exhibits: Proposed Public Works
Standards Draft Ordinance and Figures 2-33
through 2-38

Initial & Date

Concurred by Mayor: [Signature] 10/3/07
Approved by City Administrator: [Signature] 10/3/07
Approved as to form by City Atty: [Signature] 10/3/07
Approved by Finance Director:
Approved by Department Head: [Signature] 10/3/07

Table with 4 columns: Expenditure Required, Amount Budgeted, Appropriation Required, and a final 0. Values are 0, 0, 0, 0.

INFORMATION / BACKGROUND

In keeping with the same character of the City, this Ordinance would require decorative signal poles. These poles would have the same powdered forest green color, and include decorative bases and luminaires (where lighting is required). The attached Figures illustrate these decorative components. This proposed Ordinance is for future signal poles – it is not proposed that existing poles be replaced at this time.

FISCAL CONSIDERATION

The additional cost for decorative signals is approximately \$1,500 per pole. Traffic signals are often developer funded, but in some instances the City pays for new signal poles.

BOARD OR COMMITTEE RECOMMENDATION

None.

RECOMMENDATION / MOTION

Move to: Adopt Ordinance at Second Reading.

ORDINANCE NO. \_\_\_\_\_

**AN ORDINANCE OF THE CITY COUNCIL OF THE CITY OF GIG HARBOR, WASHINGTON, RELATING TO PUBLIC WORKS STANDARDS FOR NEW DEVELOPMENT IN THE CITY, AMENDING THE STANDARDS FOR DECORATIVE SIGNAL POLES AND STREETLIGHTS TO LIMIT THE SITUATIONS IN WHICH DECORATIVE SIGNAL POLES AND STREETLIGHTS MAY BE CONSTRUCTED, ESTABLISH THE DIMENSIONAL STANDARDS OF DECORATIVE SIGNAL POLES AND STREETLIGHTS, DESCRIBE THE REQUIREMENTS FOR MAINTENANCE; REPEALING SECTIONS 2E.020 AND 2F.020 OF THE CITY'S PUBLIC WORKS STANDARDS, AS ADOPTED BY ORDINANCE NO. 712; AND ADOPTING NEW SECTIONS 2E.020 AND 2F.020 TO THE CITY'S PUBLIC WORKS STANDARDS.**

---

WHEREAS, the City adopted the Public Works Standards in Ordinance No.712 ;

and

WHEREAS, the Public Works Standards currently include standards allowing for the installation of traffic signal poles; and

WHEREAS, the City installs new street lights with a decorative style, which is similar to the original street lights from the 1940 Narrows Bridge; and

WHEREAS, decorative traffic signal poles, including decorative bases, and decorative street lights, help in further defining the character and limits of the City; and

WHEREAS, the Public Works Standards require Developers to install streetlights when a development is required to provide illumination in the City's right of way ; and



WHEREAS, this ordinance is categorically exempt from SEPA under WAC 197.11.800(20); and

WHEREAS, the City Council held a public hearing and considered this Ordinance during its regular City Council meeting of September 24, 2007 ; Now, Therefore,

THE CITY COUNCIL OF THE CITY OF GIG HARBOR, WASHINGTON, ORDAINS AS FOLLOWS:

Section 1. Sections 2E.010 and 2E.020 of the City's Public Works Standards as adopted by Ordinance No. 712, and amended by Ordinances 782, 832, and 858, are hereby repealed.

Section 2. Two new Sections 2E.010 and 2E.020 are hereby added to the City of Gig Harbor Public Works Standards as adopted by Ordinance No. 712, and amended by Ordinances 858, 832, and 782.

#### 2E.010 General

Street lights will be required on all public streets or as determined by the City Engineer.

#### 2E.020 Design Standards

A street lighting plan submitted by the applicant and approved by the Public Works Director shall be required for all street light installations. Type of installation shall be as set forth in WSDOT Standard Specifications and as directed by the City except where noted herein. Street lights shall be decorative in nature, meeting the requirements of these Standards.

All public street light designs shall be prepared by an engineering firm capable of performing such work. The engineer shall be licensed by the State of Washington. All developments shall submit the lighting plan on a separate

sheet. After system design is completed and approved, a set of "record" mylars shall be submitted to the City as a permanent record.

Lights and associated foundations shall be designed in accordance with the Average Maintained Horizontal Illumination Table and related Public Works Standard Figures.

For the purposes of this section, area classes are determined by zoning as follows:

Commercial

- C1 Commercial/Light Industrial
- B1 Retail, Limited
- B2 Retail, General

Intermediate

- RB1 Residential Business
- RB2 Residential/Business
- DB Downtown Business
- WC Waterfront Commercial
- WM Waterfront Millville

Residential

- R1 Single Family
- R2 Single Family/Duplex
- R3 Multifamily

As new zones are created, they will be classified for the design of illumination by the City Engineer. If road widths differ from those in the Illuminations Standards table, other illumination spacing will be determined by the City Engineer using the following criteria:

Average Maintained Horizontal Illumination (Foot Candles, fc)				
Road Class	Area Class			
	Residential	Intermediate	Industrial	Commercial
Local	0.4	0.6	N/A	0.89
Collector	0.6	0.8	1.0	1.2
Arterial	0.8	1.2	1.4	1.6
Boulevard	N/A	1.2	1.4	1.6

Uniformity ratio: 6.1 average – minimum for 0.6 fc and less  
 4.1 average – minimum for 0.8 fc and greater

Dirt Factor = 0.85

Lamp lumen depreciation factor = 0.73  
Weak Point Light = 0.2 fc except residential local road  
Average illumination at intersections: 1.5 times the illumination required on the more highly illuminated street. Exception: In residential areas, local and collector streets intersecting other local and collector streets do not need 1.5 times the illumination provided a luminaire is placed at the intersection. These intersections shall meet the average maintained horizontal illumination for the highest road class at the intersection.

Line loss calculations shall show that no more than five percent voltage drop occurs in any circuit. Branch circuits shall serve a minimum of four luminaires.

### **GENERAL NOTES (Street Light Construction)**

1. All workmanship, materials and testing shall be in accordance with the most current edition of the WSDOT Standard Specifications, WSDOT Standard Plans, Manual on Uniform Traffic Control Devices (MUTCD), National Electrical Code (NEC), or City of Gig Harbor Public Works Standards unless otherwise specified below. In cases of conflict, the most stringent guideline shall apply.
2. Electrical permits and inspections are required for all street lighting installations within the City of Gig Harbor. The Contractor is responsible for obtaining said permits prior to any type of actual construction. These permits are available from the Washington State Department of Labor & Industries.
3. A clearly marked service disconnect shall be provided for every lighting circuit. The location and installation of the disconnect shall conform to NEC and City of Gig Harbor standards. The photo cell window shall face north unless otherwise directed by the City. The service disconnect shall not be mounted on the luminaire pole. The service disconnect shall be of a type equal to a Meyers MEUGL-M100C-UM or Unicorn CP111B-01113A service, 120/240 VAC, 103W, Caltrans Type 3B with contactors, photo electric cell and test switch. All service disconnects shall be used to their fullest capacities, i.e., maximum number of luminaires per circuit.
4. All lighting wire shall be copper with a minimum size of #8. All wire shall be suitable for wet locations. All wire shall be installed in schedule 40 PVC conduit with a minimum diameter of 1-1/4 inches. A bushing or bell-end shall be used at the end of a conduit that terminates at a junction box or luminaire pole. Conductor identification shall be an integral part of the insulation of the conductors throughout the system i.e., color coded wire. Equipment grounding conductor shall be #8 copper. All splices or taps shall be made by approved methods utilizing epoxy kits rated at 600 volts (i.e., 3-M 82-A2). All splices shall be made with pressure type connectors (wire nuts will not be allowed). Direct

burial wire will not be allowed. All other installations shall conform to NEC, WSDOT Standard Specifications and MUTCD standards.

5. Each luminaire pole shall have an in-line, fused, water-tight electrical disconnect located at the base of the pole. Access to these fused disconnects shall be through the hand-hole on the pole. The hand-hole shall be facing away from on-coming traffic. Additional conductor length shall be left inside the pole and pull or junction box equal to a loop having a diameter of one foot. Load side of in-line fuse to luminaire head shall be cable and pole bracket wire, 2 conductor, 19 strand copper #10 and shall be supported at the end of the luminaire arm by an approved means. Fuse size, disconnect installation and grounding in pole shall conform to NEC standards.
6. Approved pull boxes or junction boxes shall be installed when conduit runs are more than 200 feet. In addition, a pull box or junction box shall be located within 10 feet of each luminaire pole and at every road crossing. Boxes shall be clearly and indelibly marked as lighting boxes by the legend, "L.T." or "LIGHTING". See WSDOT Standard Plans for Road, Bridge, and Municipal Construction standard plan J-11a.
7. Mounting heights, arm length, power source, luminaire, and bolt patterns shall be as follows:

Mounting Height:	varies
Arm Length:	varies
Power Source:	240 VAC, Single Phase, 3 Wire
Luminaire Type:	250 Watt, Metal Halide (not included), ED 28 bulb, Mogul base. E.S. Type III Cut-off (asymmetrical). Sealsafe system, composed of brightened anodized aluminum hydroformed reflector, permanently assembled on a sag lens. Watertightness Ip66 rating.
Bolt Pattern:	4 Bolt, Diameter Bolt C.

8. Any modification to approved lighting plans shall be reviewed and approved by the City prior to installation.

Section 3. Section 2F.020 of the City's Public Works Standards as adopted by Ordinance No. 712, and amended by Ordinances 782, 832, and 858, is hereby repealed.

Section 4. A new Section 2F.020 is hereby added to the City of Gig Harbor Public Works Standards as adopted by Ordinance No. 712, and amended by Ordinances 858, 832, and 782.

#### 2F.020 Design Standards

Signal systems shall be designed in accordance with the most current edition of the WSDOT Standard Specifications, WSDOT Standard Plans, Manual on Uniform Traffic Control Devices (MUTCD), National Electrical Code (NEC), or City of Gig Harbor Public Works Standards unless otherwise specified, unless otherwise authorized by the City Engineer. Decorative signal poles shall also meet the requirements of these Standards.

All signal designs shall be prepared by an engineering firm capable of performing such work. The engineer shall be licensed by the State of Washington. All applicable requirements set forth in Section 2F.010 shall be included. "Figure 2-34" is hereby incorporated by this reference.

Decorative signal pole bases shall be in accordance with Figure 2-35 of these Standards. "Figure 2-35" is hereby incorporated by this reference.

All signal poles and bases located within the City's right-of-way shall be owned and maintained by the City.

Construction of decorative traffic signal poles, light poles, luminaires, and bases are the responsibility of the City for Capital Improvement Projects, and the private developer for private projects. Upon completion of the required improvements, the developer will be required to submit a statement to the City warranting that the improvements have been completed in accordance with the adopted standards and shall include a Maintenance Bond for a period of two years from the date of final acceptance.

Section 5. Severability. If any section, sentence, clause or phrase of this Ordinance is held to be invalid or unconstitutional by a court of competent jurisdiction, such invalidity or unconstitutionality shall not affect the validity or constitutionality of any other section, clause or phrase of this Ordinance.

Section 6. Effective Date. This ordinance shall take effect and be in full force five (5) days after passage and publication of an approved summary consisting of the title.

PASSED by the Council and approved by the Mayor of the City of Gig Harbor this \_\_\_\_\_ day of \_\_\_\_\_, 2005.

CITY OF GIG HARBOR

\_\_\_\_\_  
CHUCK HUNTER, MAYOR

ATTEST/AUTHENTICATED:

By: \_\_\_\_\_  
MOLLY TOWSLEE, CITY CLERK

APPROVED AS TO FORM:  
OFFICE OF THE CITY ATTORNEY:

By: \_\_\_\_\_  
CAROL A. MORRIS

FILED WITH THE CITY CLERK: \_\_\_\_\_  
PASSED BY THE CITY COUNCIL: \_\_\_\_\_  
PUBLISHED: \_\_\_\_\_  
EFFECTIVE DATE: \_\_\_\_\_  
ORDINANCE NO. \_\_\_\_\_

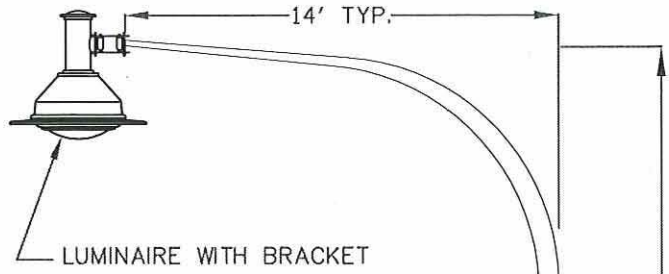

DECORATIVE LUMINAIRE SIGNAL POLE

DETAIL   
NO SCALE

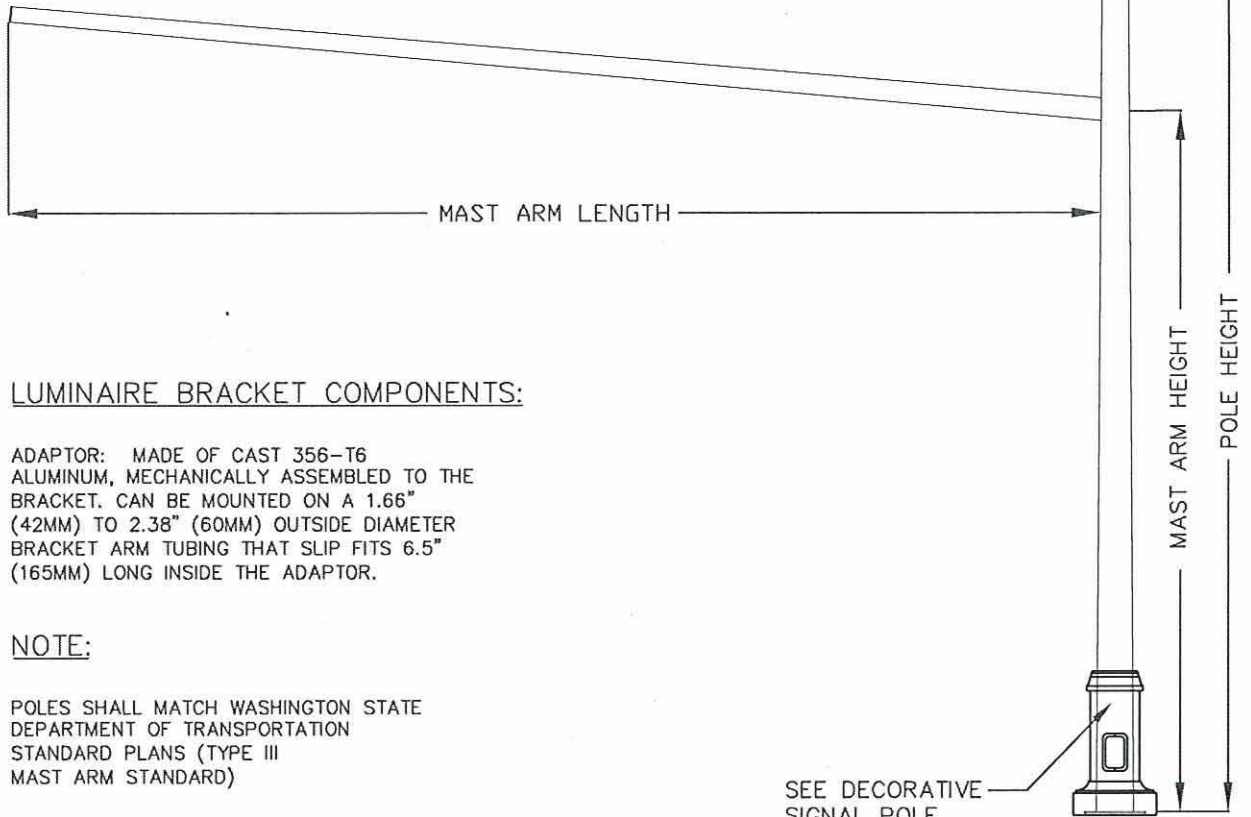

LUMINAIRE BRACKET COMPONENTS:

ADAPTOR: MADE OF CAST 356-T6 ALUMINUM, MECHANICALLY ASSEMBLED TO THE BRACKET. CAN BE MOUNTED ON A 1.66" (42MM) TO 2.38" (60MM) OUTSIDE DIAMETER BRACKET ARM TUBING THAT SLIP FITS 6.5" (165MM) LONG INSIDE THE ADAPTOR.

NOTE:

POLES SHALL MATCH WASHINGTON STATE DEPARTMENT OF TRANSPORTATION STANDARD PLANS (TYPE III MAST ARM STANDARD)

FINISH NOTES	
BASE COAT:	HOT DIPPED GALVANIZED TO ASTM A123
FINISH COAT:	TRIGLYCIDYL ISOCYANURATE (TGIC) OR URETHANE POLYESTER POWDER
COLOR:	FOREST GREEN

CITY OF GIG HARBOR DEPARTMENT OF PUBLIC WORKS			
DECORATIVE LUMINAIRE SIGNAL POLE			
APPROVED BY CITY ENGINEER _____		DATE 8/3/07	
REF	DWN ADL	CKD STM	DATE 8/3/07
			FILE FIG 2-34

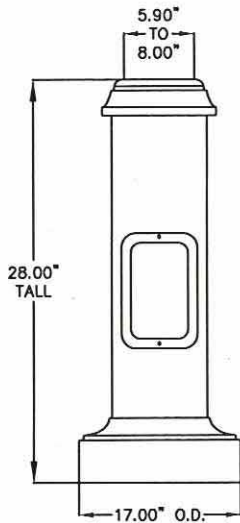

COLLAR WILL BE USED TO PROVIDE CLOSER FIT FOR 5.32" DIA. PS POLE

CLASSIC HIGH DECORATIVE BASE FOR PS POLES

17" DECORATIVE BASE

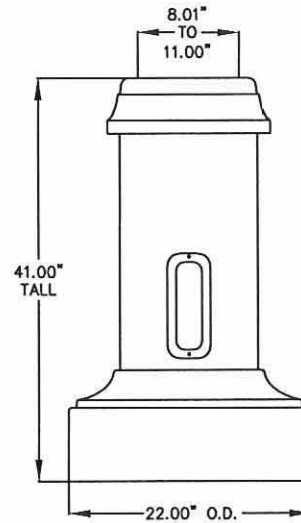

CLASSIC HIGH DECORATIVE BASE FOR POLES WITH MAXIMUM 11.00" DIA. BASE

22" DECORATIVE BASE

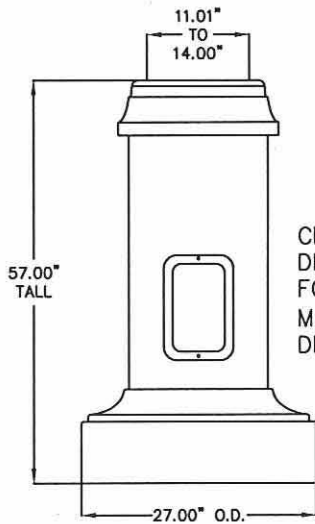

CLASSIC HIGH DECORATIVE BASE FOR POLES WITH MAXIMUM 14.00" DIA. BASE

27" DECORATIVE BASE

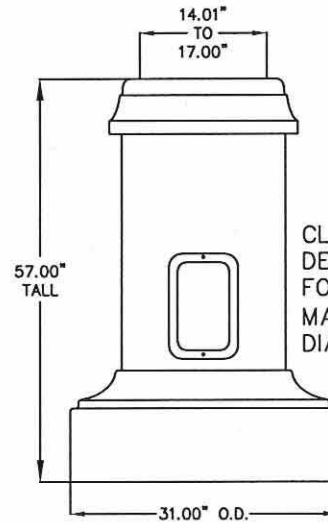

CLASSIC HIGH DECORATIVE BASE FOR POLES WITH MAXIMUM 17.00" DIA. BASE

31" DECORATIVE BASE

NOTE:

1. BASES ARE CAST ALUMINUM FOR STEEL STREET LIGHTING AND TRAFFIC POLES.
2. FACTORY FABRICATED FROM CAST AND EXTRUDED PARTS.
3. DECORATIVE BASES SHALL BE VALMONT MODEL CHXXAB OR APPROVED EQUAL.

DECORATIVE  
SIGNAL POLE BASE

DETAIL 

NO SCALE

FINISH NOTES

FINISH COAT: TRIGLYCIDYL ISOYANURATE (TGIC)  
OR URETHANE POLYESTER POWDER

APPLICATION TO BE TEXTURED

COLOR: FOREST GREEN

CITY OF GIG HARBOR  
DEPARTMENT OF PUBLIC WORKS

DECORATIVE  
SIGNAL POLE BASE

APPROVED BY \_\_\_\_\_ DATE 8/3/07  
CITY ENGINEER

REF

DWN	CKD	DATE	FILE
ADL	STM	8/3/07	FIG 2-35



**ANCHOR PLATE**

B.C.: 12 1/2"  $\phi$   
 317mm  $\phi$   
 THICKNESS: 1"  $\phi$   
 25mm

**NOTE:**

THIS ANCHOR PLATE ACCEPTS  
 • A BOLT CIRCLE FROM  
 11 1/4"  $\phi$  @ 13"  $\phi$   
 286mm  $\phi$  @ 330mm  $\phi$

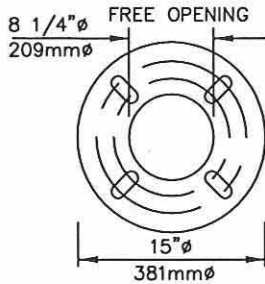

**BASE DETAILS**

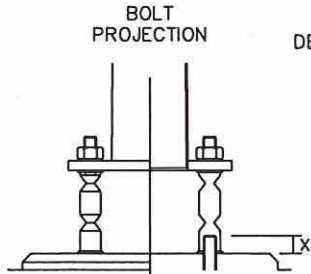

X = 1 3/8" (35mm) MAX.  
 COMES WITH 4 ANCHOR BOLTS,  
 4 BREAKAWAY COUPLINGS #4100  
 4 NUTS AND 8 WASHERS.

- ANCHORING BOLTS  
 STEEL, 1" x 36"

**DECORATIVE  
 LIGHT POLE**

**DETAIL**  
 NO SCALE

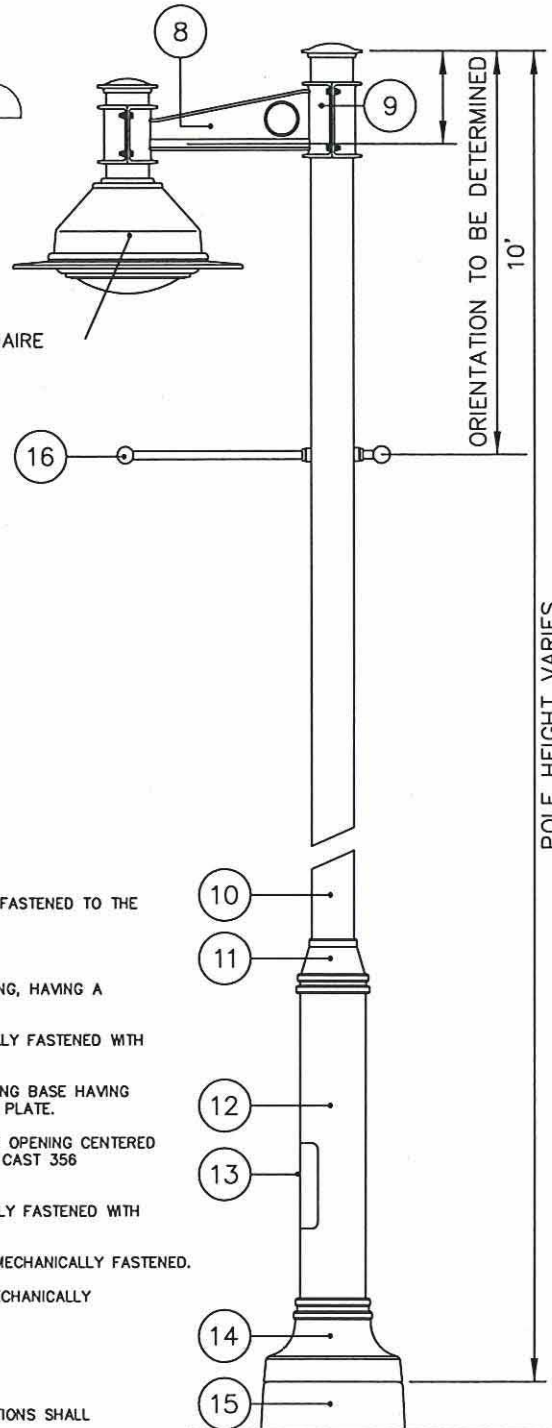

**BRACKET:**

- 8 ARM: MADE OF CAST 356 ALUMINUM, WELDED.
- 9 ADAPTOR: CLAMPS MADE OF CAST 356 ALUMINUM, WELDED TO THE ARM AND MECHANICALLY FASTENED TO THE POLE BY 4 BOLTS AND NUTS.

**POLE:**

- 10 POLE SHAFT: SHALL BE MADE FROM 5"U"(141mm) ROUND HIGH TENSILE CARBON STEEL TUBING, HAVING A 0.250" (6.4mm) WALL THICKNESS, WELDED TO THE POLE BASE.
- 11 JOINT COVER: TWO PIECE ROUND JOINT COVER MADE FROM CAST 356 ALUMINUM, MECHANICALLY FASTENED WITH STAINLESS STEEL SCREWS.
- 12 POLE BASE: SHALL BE MADE FROM A 8"K"(219mm) ROUND HIGH TENSILE CARBON STEEL TUBING BASE HAVING A 0.180" (4.6mm) WALL THICKNESS, WELDED TO BOTH THE BOTTOM AND TOP OF THE ANCHOR PLATE.
- 13 MAINTENANCE OPENING: THE POLE SHALL HAVE A 4" x 10" (102mm x 254mm) MAINTENANCE OPENING CENTERED 25'4" (641mm) FROM THE BOTTOM OF THE ANCHOR PLATE, COMPLETE WITH A WEATHERPROOF CAST 356 ALUMINUM COVER AND A FACTORY ASSEMBLED COPPER GROUND LUG.
- 14 BASE COVER: TWO PIECE ROUND BASE COVER MADE FROM CAST 356 ALUMINUM, MECHANICALLY FASTENED WITH STAINLESS STEEL SCREWS.
- 15 BREAK AWAY COVER: ONE PIECE ROUND BASE COVER MADE FROM SPUN 1100-0 ALUMINUM, MECHANICALLY FASTENED.
- 16 POLE OPTIONS: BANNER ARM MADE OF ALUMINUM TUBING, 1'6"(27mm) OUTSIDE DIAMETER, MECHANICALLY ASSEMBLED TO THE POLE.

WIRING: TYPE TEW 14 GA. 12" (305mm) MINIMUM EXCEEDING TOP OF POLE. ALL ELECTRICAL CONNECTIONS SHALL BE MADE WITH QUICK-DISCONNECT CONNECTORS.

HARDWARE: ALL EXPOSED SCREWS WILL BE IN STAINLESS STEEL. NEOPRENE AND/OR SILICONE GASKETING IS APPLIED.

FINISH: COLOR TO BE FOREST GREEN. APPLICATION OF A TEXTURED POLYESTER POWDER COAT PAINT. (4 MILS/100 MICRONS). THE CHEMICAL COMPOSITION PROVIDE A HIGHLY DURABLE UV AND SALT SPRAY RESISTANT FINISH IN ACCORDANCE TO THE ASTM-B117-73 STANDARD AND HUMIDITY PROOF IN ACCORDANCE TO THE ASTM-D2247-68 STANDARD.

CITY OF GIG HARBOR DEPARTMENT OF PUBLIC WORKS			
DECORATIVE LIGHT POLE HIGHER THAN 15 FEET			
APPROVED BY CITY ENGINEER _____		DATE 8/3/07	
REF	DWN ADL	CKD STM	DATE 8/3/07 FILE FIG 2-36

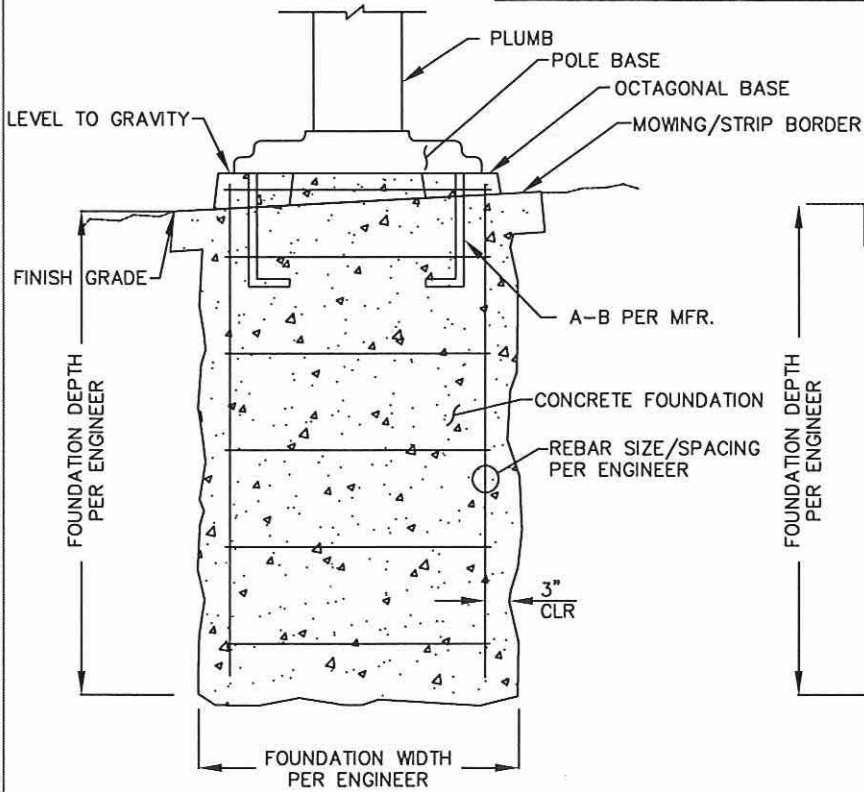
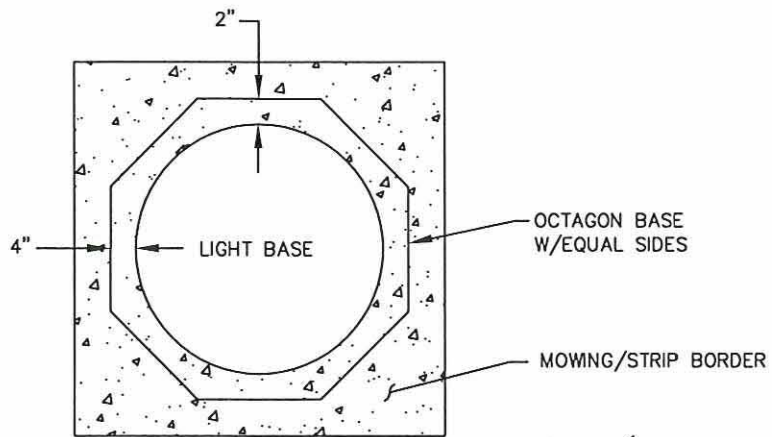

SLOPED GRADE APPLICATIONS

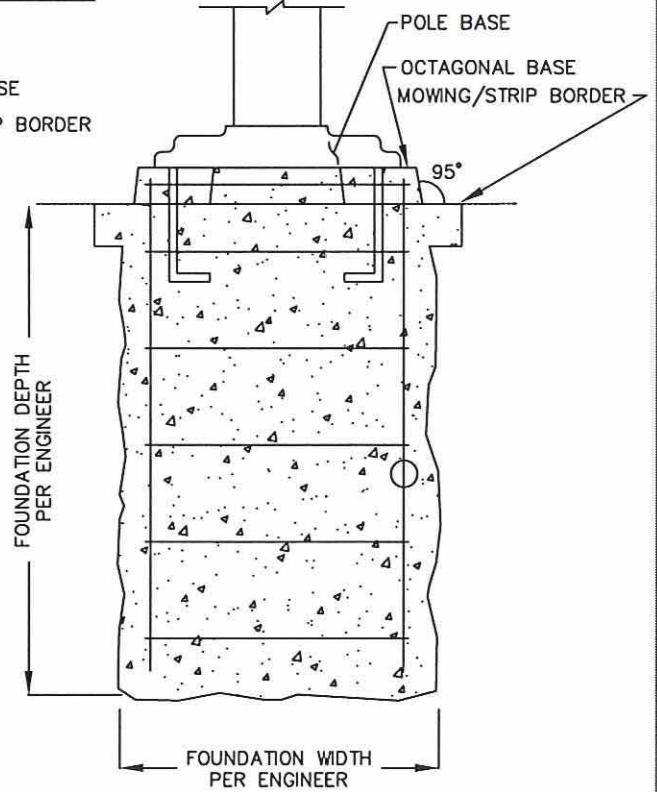

LEVEL GRADE APPLICATIONS

NOTE:  
 SIZE OF OCTAGON BASE  
 AND MOWING STRIP/BORDER  
 ARE DETERMINED BY SIZE  
 OF STREET LIGHT BASE

LUMINAIRE  
 FOUNDATION

DETAIL   
 NO SCALE

CITY OF GIG HARBOR  
 DEPARTMENT OF PUBLIC WORKS

LUMINAIRE  
 FOUNDATION DETAIL

APPROVED BY \_\_\_\_\_ DATE 8/3/07  
 CITY ENGINEER

REF

DWN	CKD	DATE	FILE
ADL	STM	8/9/07	FIG 2-37

REV. NO:

# DECORATIVE LIGHT POLE

## DETAIL

NO SCALE

LUMINAIRE: DMS50-175MH-SG3-240-GN6TX

- 1 HOOD: SPUN ALUMINUM 1100-0 DOME, MECHANICALLY ASSEMBLED ON THE LUMINAIRE.
- 2 REFLECTOR: SPUN 1100-0 ALUMINUM, MECHANICALLY ASSEMBLED ON THE LUMINAIRE.
- 3 LENS: CLEAR TEMPERED GLASS LENS, MECHANICALLY ASSEMBLED ON THE LOWER PART OF THE TECHNICAL RING WITH BRACKETS.
- 4 LAMP: (NOT INCLUDED), 175 WATT METAL HALIDE (ANSI CODE M57), ED 28 BULB, MOGUL BASE.
- 5 OPTICAL SYSTEM: (SG3), I.E.S. TYPE III (ASYMMETRICAL), REFLECTOR COMPOSED OF A CHEMICALLY BRIGHTENED MULTI-FACETED ANODIZED ALUMINUM, MOUNTED ON A WHITE FRAME. THIS ASSEMBLY ALLOWS FOR A FULL ROTATION OF THE OPTICAL SYSTEM IN 90 DEGREE INCREMENTS.
- 6 BALLAST: HIGH POWER FACTOR OF 90% PRIMARY VOLTAGE 240 VOLTS. LAMP STARTING CAPACITY -20 F DEGREES. ASSEMBLED ON A UNITIZED REMOVABLE TRAY WITH QUICK DISCONNECT PLUG.
- 7 ACCESS-MECHANISM: A DIE CAST A360 ALUMINUM TECHNICAL RING WITH LATCH AND HINGE. THE MECHANISM SHALL OFFER TOOL-FREE ACCESS TOT HE INSIDE OF THE LUMINAIRE. AN EMBEDDED MEMORY-RETENTIVE GASKET SHALL ENSURE WEATHERPROOFING.
- 8 HOUSING: IN A ROUND SHAPE, THIS HOUSING IS MADE OF CAST 356 ALUMINUM, C/W A WEATHERPROOF GROMMET, MECHANICALLY ASSEMBLED TO THE BRACKET WITH FOUR BOLTS 3/8-16 UNC. THIS SUSPENSION SYSTEM PERMITS FOR A FULL ROTATION OF THE LUMINAIRE IN 90 DEGREE INCREMENTS.

BRACKET: MM-1A-GN6TX

- 9 ARM: MADE FROM 2 3/8 IN. OUTSIDE DIAMETER ALUMINUM TUBING, WELDED.
- 10 DECORATIVE ELEMENT: MADE OF CAST 356 ALUMINUM, WELDED.
- 11 CENTRAL TUBING: MADE OF ALUMINUM 6063-T6, 4 1/2" OUTSIDE DIAMETER. SLIP-FITS 9" OVER A 4" OUTSIDE DIAMETER POLE TENON. MECHCANICALLY FASTENED BY TWO SETS OF THREE SET SCREWS AT 120 DEGREES AROUND THE BRACKET.

POLE: AMBU-15-BA-GN6TX

- 12 POLE SHAFT: SHALL BE MADE FROM A 4" ROUND EXTRUDED 6061-T6 ALUMINUM TUBING, HAVING A 0.226" WALL THICKNESS, WELDED TO THE POLE BASE.
- 13 JOINT COVER: TWO-PIECE ROUND JOINT COVER MADE FROM CAST 356 ALUMINUM, MECHANICALLY FASTENED WITH STAINLESS STEEL SCREWS.
- 14 POLE BASE: SHALL BE MADE FROM A 8 5/8" ROUND EXTRUDED 6061-T6 ALUMINUM TUBING BASE HAVING A 0.148" WALL THICKNESS, WELDED TO BOTH THE BOTTOM AND TOP OF THE ACHOR PLATE.
- 15 MAINTENANCE OPENING: THE POLE SHALL HAVE A 4" X 10" MAINTENANCE OPENING CENTERED 25 1/4" FROM THE BOTTOM OF THE ACHOR PLATE, COMPLETE WITH A WEATHERPROOF CAST 356 ALUMINUM COVER AND A COPPER GROUND LUG.
- 16 BASE COVER: TWO PIECE ROUND BASE COVER MADE FROM CAST 356 ALUMINUM, MECHANICALLY FASTENED WITH STAINLESS STEEL SCREWS.
- 17 POLE OPTIONS: (BA) SINGLE, SINGLE ARM(S) (1), FIXED STANDARD TYPE, MADE OF STEEL TUBING, 1 1/16" OUTSIDE DIAMETER, MECHANICALLY ASSEMBLED TO THE POLE, COMPLETE WITH A STANDARD CAST ALUMINUM DECORATIVE BALL, SET AT 12'0" ABOVE BASE.

### DESCRIPTION OF COMPONENTS:

WIRING: GAUGE (#14) TEW WIRES, 6" MINIMUM EXCEEDING TOP OF THE BRACKET.

HARDWARE: ALL EXPOSED SCREWS WILL BE IN STAINLESS STEAL. ALL SEALS AND SEALING DEVICES ARE MADE AND/OR SILCONE.

FINISH: COLOR TO BE FOREST GREEN TEXTURED (GN6TX). APPLICATION OF A POLYESTER COAT PAINT. (4 MILS/100 MICRONS). THE CHEMICAL COPOSITION PROVIDES A HIGHLY DURABLE UV AND SALT SPRAY RESISTANT FINISH IN ACCORDANCE TOTHE ASTM-B117-73 STANDARD AND HUMIDITY PROOF IN ACCORDANCE TO THE ASTM-D2247-68 STANDARD.

### NOTES:

1. SEE DETAIL 2-64 FOR 15' DECORATIVE LUMINAIRE CONSTRUCTION DETAILS.

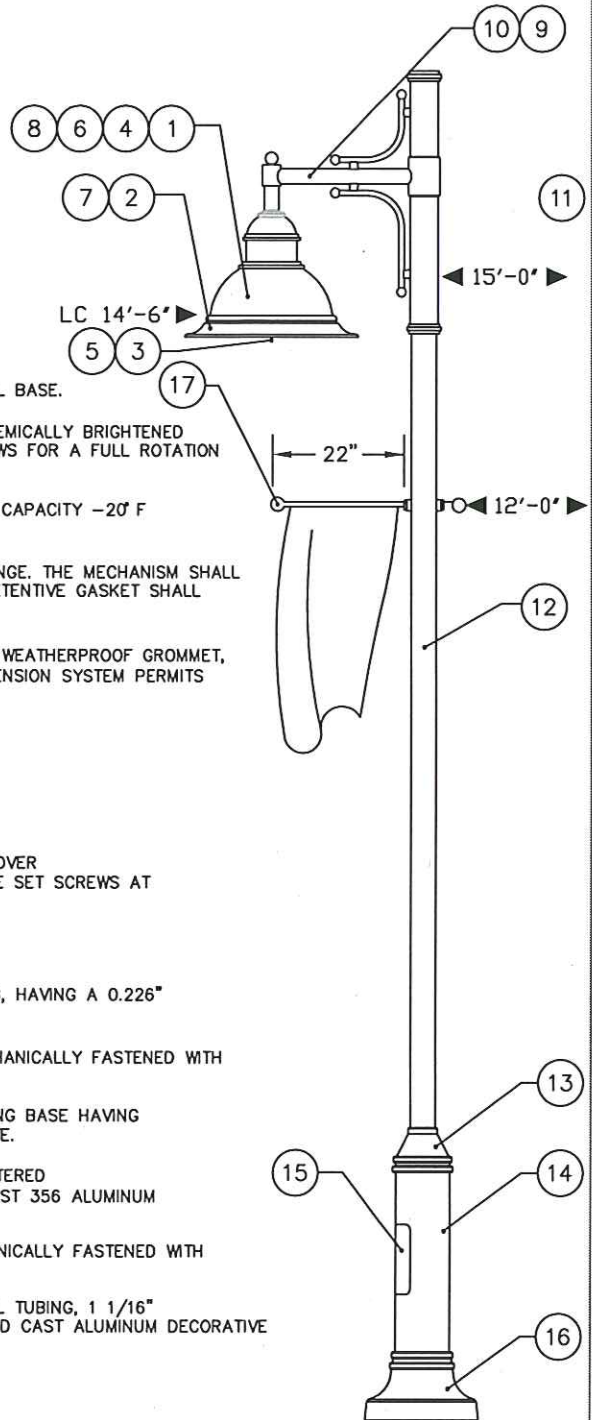

CITY OF GIG HARBOR  
DEPARTMENT OF PUBLIC WORKS

## DECORATIVE LIGHT POLE 15 FEET AND UNDER

APPROVED BY \_\_\_\_\_ DATE 9/12/07  
CITY ENGINEER \_\_\_\_\_

REF	DWN ADL	CKD STM	DATE 9/12/07	FILE FIG 2-38
-----	------------	------------	-----------------	------------------



**Business of the City Council  
City of Gig Harbor, WA**

**Subject:** Public Hearing and First Reading of Ordinance - Minimum Lot Size Amendments.

**Proposed Council Action:** Review ordinance and approve at second reading.

**Dept. Origin:** Community Development

**Prepared by:** Jennifer Kester *JK*  
Senior Planner

**For Agenda of:** October 8, 2007

**Exhibits:** Draft Ordinance

Initial & Date

**Concurred by Mayor:** *CLA 10/3/07*  
**Approved by City Administrator:** *RJK 10/3/07*  
**Approved as to form by City Atty:** *CAM 10/3/07*  
**Approved by Finance Director:** \_\_\_\_\_  
**Approved by Department Head:** *Dave 10/2/07*

Expenditure Required	0	Amount Budgeted	0	Appropriation Required	0
----------------------	---	-----------------	---	------------------------	---

**INFORMATION / BACKGROUND**

The proposed amendments relate to two exceptions to minimum lot size standards in the City's Zoning Code:

The first exception proposed relates to the combination of two legally nonconforming lots. On April 24, 2006, the City adopted a code provision amending the criteria of approval of a boundary line adjustment when an owner of two or more legally created nonconforming lots wanted to combine such lots, even if the application would transform a legally created lot into a substandard, undersized lot. Later in 2006, a Washington State Court invalidated a similar provision in another jurisdiction. Therefore, the City Attorney has indicated that the City cannot approve a boundary line adjustment application that combines two or more lots when the resulting lot does not meet minimum lot area standards of the zoning district in which it is located. The proposed amendment repeals the boundary line adjustment provision in 16.03.004 that was found to be invalid.

As an alternative to the use of a boundary line adjustment to combine two or more legal small lots into a larger but still nonconforming lot, City staff is proposing a minimum lot area exception. The provisions in the proposed ordinance (17.01.100) would allow the combination of legal nonconforming lots even if the resulting lot does not satisfy the minimum lot area requirements for the zoning district within which it is located. The amendment would reduce nonconformities and promote infill. The proposed exception would consider two or more, legally nonconforming lots, as to lot area, as one building site if combined together, no matter the resulting size. The proposed exception would allow the same combination as

contemplated in the 2006 boundary line adjustment ordinance as the resulting lot would meet the minimum lot area standards of the zoning code due to the exception and therefore the boundary line adjustment could be approved.

The second exception proposed relates to the dedication of property to the public. The exception would allow that portion of a lot remaining after dedication or sale of a portion of the lot to the City or state for street or highway purposes as a separate building site, as long as the area of the remaining lot is at least 3,000 square feet.

### **POLICY CONSIDERATIONS**

Zoning text amendments are addressed in Chapter 17.100 of the Gig Harbor Municipal Code. There are no criteria for approval of a zoning text amendment, but the Council should generally consider whether the proposed amendment furthers the public health, safety and welfare, and whether the proposed amendment is consistent with the Gig Harbor Municipal Code, the Comprehensive Plan and the Growth Management Act (chapter 36.70A RCW). Zoning text amendments are considered a Type V legislative action (GHMC 19.01.003).

### **ENVIRONMENTAL ANALYSIS**

The City's SEPA Responsible Official issued a DNS for the proposed amendments on September 12, 2007 pursuant to WAC 197-11-340.

### **FISCAL CONSIDERATION**

None

### **BOARD OR COMMITTEE RECOMMENDATION**

The Planning and Building Committee of the Council discussed the minimum lot area exception for nonconforming lots combinations and repealing of the nonconforming lot boundary line adjustment procedures at their meetings in March, April, May and June of 2007. The committee was in support of those amendments. The committee did not review minimum lot area exception for dedication of public property in those meetings.

The Planning Commission did not review this proposed ordinance, but did review the amendments to the boundary line adjustment chapter that were adopted in April of 2006. The Planning Commission was unanimous in their support of a process to allow the combination of legally nonconforming lots.

### **RECOMMENDATION / MOTION**

**Move to:** Staff recommends Council review the ordinance and approve at second reading.

ORDINANCE NO. \_\_\_\_\_

**AN ORDINANCE OF THE CITY COUNCIL OF THE CITY OF GIG HARBOR, WASHINGTON, RELATING TO LAND USE, ZONING AND BOUNDARY LINE ADJUSTMENTS, ELIMINATING THE PROCEDURE ALLOWING FOR NONCONFORMING LOT COMBINATIONS AS A RESULT OF NEW CASE LAW, DESCRIBING EXCEPTIONS TO THE MINIMUM LOT AREA REQUIREMENTS, ALLOWING TWO OR MORE LEGALLY NONCONFORMING LOTS TO BE COMBINED INTO ONE LOT, AND ALLOWING DEVELOPMENT OF A LOT EVEN THOUGH A PORTION OF THE LOT HAS BEEN DEDICATED OR SOLD TO THE CITY OR STATE FOR STREET PURPOSES, REPEALING GIG HARBOR MUNICIPAL CODE SECTION 16.03.004 AND ADDING A NEW SECTION 17.01.100 TO THE GIG HARBOR MUNICIPAL CODE.**

---

WHEREAS, the City recognizes lots that have been established through recorded plats under previous codes as legally nonconforming lots; and

WHEREAS, the City adopted a code provision that would allow an owner of two or more legally created nonconforming lots to combine such lots through a boundary line adjustment, even if the application would transform a legally created lot into a substandard, undersized lot (GHMC Section 16.03.004); and

WHEREAS, the Washington Court recently addressed this issue, and determined that RCW 58.17.040(6) does not allow a local jurisdiction to approve a boundary line application that would transform a legally created lot into a substandard, undersized lot (*Mason v. King County*, 134 Wn. App. 806, 142 P.3d 637 (2006)); and

WHEREAS, the owner of two or more legally nonconforming lots may desire to combine the lots into one, even if the resulting lot does not meet the minimum lot area requirements for the underlying zone, but the owner may not be able to do so with a boundary line adjustment or under the subdivision code; and

WHEREAS, the City believes that the combination of two or more legally nonconforming lots is desirable, even if the resulting lot does not meet the code, because the resulting lot will conform to the existing code to a greater degree; and

WHEREAS, the City seeks to encourage the dedication and/or sale of property to the City and state for street purposes, without necessity of a "friendly condemnation action" to legalize the remaining lot; and

WHEREAS, the City's SEPA Responsible Official issued a DNS for the proposed amendments on September 12, 2007 pursuant to WAC 197-11-340, which was \_\_\_\_ appealed; and

WHEREAS, the City Community Development Director forwarded a copy of this Ordinance to the Washington State Department of Community, Trade and Economic Development on August 22, 2007, pursuant to RCW 36.70A.106; and

WHEREAS, the Gig Harbor City Council considered the Ordinance at first reading and public hearing on \_\_\_\_\_; and

WHEREAS, the Gig Harbor City Council voted to \_\_\_\_\_ this Ordinance during the second reading on \_\_\_\_\_; Now, Therefore,

THE CITY COUNCIL OF THE CITY OF GIG HARBOR, WASHINGTON, ORDAINS AS FOLLOWS:

Section 1. Section 16.03.004 of the Gig Harbor Municipal Code is hereby repealed.

Section 2. A new Section 17.01.100 is hereby added to the Gig Harbor Municipal Code, which shall read as follows:

**17.01.100 Exceptions to Minimum Lot Area.**

A lot which does not satisfy the minimum lot area requirements of the applicable zone may be developed as a separate building site, according to the following:

A. Combination of legally nonconforming lots. A property owner of two or more lots that are legally nonconforming as to lot area may request that the lots be combined into one larger lot, even if the resulting lot does not satisfy the existing lot area requirements in the underlying zone, as long as the Director determines that the property owner has submitted sufficient evidence to demonstrate that the original lots are legally nonconforming. In addition, the lot combination shall satisfy the requirements of and be processed according to the procedures in chapter 16.03 GHMC, with the exception of Subsection 16.03.003(B). This section does not apply in any overlay district to allow the combination of any lots created through the Mixed Use Overlay District (MUD), a Planned Unit Development (PUD) or Planned Residential District (PRD).

B. Dedication of property to the public. That portion of a lot remaining after dedication or sale of a portion of the lot to the City or state for street or highway purposes shall be a separate building site, as long as the area of the remaining lot is at least 3,000 square feet.

Section 3. Severability. If any section, sentence, clause or phrase of this Ordinance is held to be invalid or unconstitutional by a court of competent jurisdiction, such invalidity or unconstitutionality shall not affect the validity or constitutionality of any other section, clause or phrase of this Ordinance.

Section 4. Effective Date. This Ordinance shall take effect and be in full force five (5) days after passage and publication of an approved summary consisting of the title.

PASSED by the City Council and approved by the Mayor of the City of Gig Harbor this \_\_\_ day of \_\_\_\_\_, 200\_.

CITY OF GIG HARBOR

\_\_\_\_\_  
CHARLES L. HUNTER, MAYOR

ATTEST/AUTHENTICATED:

By: \_\_\_\_\_  
MOLLY TOWSLEE, City Clerk

APPROVED AS TO FORM:  
OFFICE OF THE CITY ATTORNEY

By: \_\_\_\_\_  
CAROL A. MORRIS

FILED WITH THE CITY CLERK: \_\_\_\_\_  
PASSED BY THE CITY COUNCIL: \_\_\_\_\_  
PUBLISHED: \_\_\_\_\_  
EFFECTIVE DATE: \_\_\_\_\_  
ORDINANCE NO: \_\_\_\_\_





Business of the City Council
City of Gig Harbor, WA

Subject: Austin Estuary Park Aquatic Lease Survey

Proposed Council Action: Authorize the execution of the Consultant Services Contract with PriZm Surveying, Inc. for survey work in the amount not to exceed Nineteen Thousand Seven Hundred Fifty Dollars and No Cents (\$19,750.00).

Dept. Origin: Community Development

Prepared by: David Brereton (signature) Director of Operations

For Agenda of: October 8, 2007

Exhibits: Consultant Services Contract

Initial & Date

Concurred by Mayor: (signature) 10/3/07

Approved by City Administrator: (signature) 10/3/07

Approved as to form by City Atty: CAM 10/3/07

Approved by Finance Director: \_\_\_\_\_

Approved by Department Head: (signature) \_\_\_\_\_

Table with 3 columns: Expenditure, Amount, Appropriation. Row 1: Required \$19,750.00, Budgeted \$0, Required See Fiscal Note Below.

INFORMATION / BACKGROUND

The City of Gig Harbor has submitted application to lease state-owned aquatic lands for the public use from Washington State Department of Natural Resources adjacent to the Austin Estuary Park. A requirement of the application is to provide a record survey of the new lease area by a licensed surveyor.

After reviewing the Consultant Services Roster, the City contacted the survey firm of Prizm Surveying, Inc. and requested quotations to provide the above services. Upon review of the provided price quotations and proposals, the survey firm of PriZm Surveying, Inc. was selected to perform the work. Selection was based on their understanding of the project, extensive municipal survey experience, and outstanding recommendations from outside jurisdictions that have used the selected consultant for similar tasks.

The scope of work includes identifying the government's meander line, tide lines and the harbor lines. They will also prepare lease area legal descriptions and check for closure and record final drawing with the Pierce County Auditor.

FISCAL CONSIDERATION

This project was not anticipated in the adopted 2007 budget. However sufficient funds are available under professional services in the 2007 Park operating budget.

BOARD OR COMMITTEE RECOMMENDATION

N/A

**RECOMMENDATION / MOTION**

**Move to:** Authorize the execution of the Consultant Services Contract with PriZm Surveying, Inc. for survey work in the amount not to exceed Nineteen Thousand Seven Hundred Fifty Dollars and No Cents (\$19,750.00).

**CONSULTANT SERVICES CONTRACT  
BETWEEN THE CITY OF GIG HARBOR AND  
PRIZM SURVEYING, INC.**

THIS AGREEMENT is made by and between the City of Gig Harbor, a Washington municipal corporation (hereinafter the "City"), and PriZm Surveying, Inc., a corporation organized under the laws of the State of Washington, located and doing business at PO Box 110700, Tacoma, Washington 98411 (hereinafter the "Consultant").

**RECITALS**

WHEREAS, the City is presently engaged in the survey and mapping work for the Aquatic Lease Survey (Austin Estuary Park Site Parcel No(s) 02-21-06-4-039 and 02-21-06-4-043) for D.N.R. Application and desires that the Consultant perform services necessary to provide the following consultation services.

WHEREAS, the Consultant agrees to perform the services more specifically described in the Scope of Work, dated August 15, 2007 including any addenda thereto as of the effective date of this agreement, all of which are attached hereto as **Exhibit A – Scope of Services**, and are incorporated by this reference as if fully set forth herein.

NOW, THEREFORE, in consideration of the mutual promises set forth herein, it is agreed by and between the parties as follows:

**TERMS**

**I. Description of Work**

The Consultant shall perform all work as described in **Exhibit A**.

**II. Payment**

A. The City shall pay the Consultant an amount based on time and materials, not to exceed Nineteen Thousand Seven Hundred Fifty Dollars and No Cents (\$19,750.00) for the services described in Section I herein. This is the maximum amount to be paid under this Agreement for the work described in **Exhibit A**, and shall not be exceeded without the prior written authorization of the City in the form of a negotiated and executed supplemental agreement. PROVIDED, HOWEVER, the City reserves the right to direct the Consultant's compensated services under the time frame set forth in Section IV herein before reaching the maximum amount.

B. The Consultant shall submit monthly invoices to the City after such services have been performed, and a final bill upon completion of all the services described in this Agreement. The City shall pay the full amount of an invoice within forty-five (45) days of

receipt. If the City objects to all or any portion of any invoice, it shall so notify the Consultant of the same within fifteen (15) days from the date of receipt and shall pay that portion of the invoice not in dispute, and the parties shall immediately make every effort to settle the disputed portion.

### III. Relationship of Parties

The parties intend that an independent contractor-client relationship will be created by this Agreement. As the Consultant is customarily engaged in an independently established trade which encompasses the specific service provided to the City hereunder, no agent, employee, representative or sub-consultant of the Consultant shall be or shall be deemed to be the employee, agent, representative or sub-consultant of the City. In the performance of the work, the Consultant is an independent contractor with the ability to control and direct the performance and details of the work, the City being interested only in the results obtained under this Agreement. None of the benefits provided by the City to its employees, including, but not limited to, compensation, insurance, and unemployment insurance are available from the City to the employees, agents, representatives, or sub-consultants of the Consultant. The Consultant will be solely and entirely responsible for its acts and for the acts of its agents, employees, representatives and sub-consultants during the performance of this Agreement. The City may, during the term of this Agreement, engage other independent contractors to perform the same or similar work that the Consultant performs hereunder.

### IV. Duration of Work

The City and the Consultant agree that work will begin on the tasks described in **Exhibit A** immediately upon execution of this Agreement. The parties agree that the work described in **Exhibit A** shall be completed by December 31, 2007; provided however, that additional time shall be granted by the City for excusable days or extra work.

### V. Termination

A. Termination of Agreement. The City may terminate this Agreement, for public convenience, the Consultant's default, the Consultant's insolvency or bankruptcy, or the Consultant's assignment for the benefit of creditors, at any time prior to completion of the work described in **Exhibit A**. If delivered to consultant in person, termination shall be effective immediately upon the Consultant's receipt of the City's written notice or such date stated in the City's notice, whichever is later.

B. Rights Upon Termination. In the event of termination, the City shall pay for all services satisfactorily performed by the Consultant to the effective date of termination, as described on a final invoice submitted to the City. Said amount shall not exceed the amount in Section II above. After termination, the City may take possession of all records and data within the Consultant's possession pertaining to this Agreement, which records

and data may be used by the City without restriction. Upon termination, the City may take over the work and prosecute the same to completion, by contract or otherwise. Except in the situation where the Consultant has been terminated for public convenience, the Consultant shall be liable to the City for any additional costs incurred by the City in the completion of the Scope of Work and Cost referenced as **Exhibit A** and as modified or amended prior to termination. "Additional Costs" shall mean all reasonable costs incurred by the City beyond the maximum contract price specified in Section II(A), above.

## **VI. Discrimination**

In the hiring of employees for the performance of work under this Agreement or any sub-contract hereunder, the Consultant, its subcontractors, or any person acting on behalf of such Consultant or sub-consultant shall not, by reason of race, religion, color, sex, national origin, or the presence of any sensory, mental, or physical disability, discriminate against any person who is qualified and available to perform the work to which the employment relates.

## **VII. Indemnification**

The Consultant shall defend, indemnify and hold the City, its officers, officials, employees, agents and volunteers harmless from any and all claims, injuries, damages, losses or suits, including all legal costs and attorneys' fees, arising out of or in connection with the performance of this Agreement, except for injuries and damages caused by the sole negligence of the City. The City's inspection or acceptance of any of the Consultant's work when completed shall not be grounds to avoid any of these covenants of indemnification.

Should a court of competent jurisdiction determine that this Agreement is subject to RCW 4.24.115, then, in the event of liability for damages arising out of bodily injury to persons or damages to property caused by or resulting from the concurrent negligence of the Consultant and the City, its officers, officials, employees, agents and volunteers, the Consultant's liability hereunder shall be only to the extent of the Consultant's negligence.

IT IS FURTHER SPECIFICALLY AND EXPRESSLY UNDERSTOOD THAT THE INDEMNIFICATION PROVIDED HEREIN CONSTITUTES THE CONSULTANT'S WAIVER OF IMMUNITY UNDER INDUSTRIAL INSURANCE, TITLE 51 RCW, SOLELY FOR THE PURPOSES OF THIS INDEMNIFICATION. THE PARTIES FURTHER ACKNOWLEDGE THAT THEY HAVE MUTUALLY NEGOTIATED THIS WAIVER. THE CONSULTANT'S WAIVER OF IMMUNITY UNDER THE PROVISIONS OF THIS SECTION DOES NOT INCLUDE, OR EXTEND TO, ANY CLAIMS BY THE CONSULTANT'S EMPLOYEES DIRECTLY AGAINST THE CONSULTANT.

The provisions of this section shall survive the expiration or termination of this Agreement.

## VIII. Insurance

A. The Consultant shall procure and maintain for the duration of the Agreement, insurance against claims for injuries to persons or damage to property which may arise from or in connection with the Consultant's own work including the work of the Consultant's agents, representatives, employees, sub-consultants or sub-contractors.

B. Before beginning work on the project described in this Agreement, the Consultant shall provide evidence, in the form of a Certificate of Insurance, of the following insurance coverage and limits (at a minimum):

1. Business auto coverage for any auto no less than a \$1,000,000 each accident limit, and
2. Commercial General Liability insurance no less than \$1,000,000 per occurrence with a \$2,000,000 aggregate. Coverage shall include, but is not limited to, contractual liability, products and completed operations, property damage, and employers liability, and
3. Professional Liability insurance with no less than \$1,000,000.

All policies and coverage's shall be on an occurrence made basis.

C. The Consultant is responsible for the payment of any deductible or self-insured retention that is required by any of the Consultant's insurance. If the City is required to contribute to the deductible under any of the Consultant's insurance policies, the Contractor shall reimburse the City the full amount of the deductible within 10 working days of the City's deductible payment.

D. The City of Gig Harbor shall be named as an additional insured on the Consultant's commercial general liability policy. This additional insured endorsement shall be included with evidence of insurance in the form of a Certificate of Insurance for coverage necessary in Section B. The City reserves the right to receive a certified and complete copy of all of the Consultant's insurance policies.

E. Under this agreement, the Consultant's insurance shall be considered primary in the event of a loss, damage or suit. The City's own comprehensive general liability policy will be considered excess coverage with respect to defense and indemnity of the City only and no other party. Additionally, the Consultant's commercial general liability policy must provide cross-liability coverage as could be achieved under a standard ISO separation of insured's clause.

F. The Consultant shall request from his insurer a modification of the ACORD certificate to include language that prior written notification will be given to the City of Gig

Harbor at least 30-days in advance of any cancellation, suspension or material change in the Consultant's coverage.

### **IX. Exchange of Information**

The City warrants the accuracy of any information supplied by it to the Consultant for the purpose of completion of the work under this Agreement. The parties agree that the Consultant will notify the City of any inaccuracies in the information provided by the City as may be discovered in the process of performing the work, and that the City is entitled to rely upon any information supplied by the Consultant which results as a product of this Agreement.

### **X. Ownership and Use of Records and Documents**

Original documents, drawings, designs and reports developed under this Agreement shall belong to and become the property of the City. All written information submitted by the City to the Consultant in connection with the services performed by the Consultant under this Agreement will be safeguarded by the Consultant to at least the same extent as the Consultant safeguards like information relating to its own business. If such information is publicly available or is already in consultant's possession or known to it, or is rightfully obtained by the Consultant from third parties, the Consultant shall bear no responsibility for its disclosure, inadvertent or otherwise.

### **XI. City's Right of Inspection**

Even though the Consultant is an independent contractor with the authority to control and direct the performance and details of the work authorized under this Agreement, the work must meet the approval of the City and shall be subject to the City's general right of inspection to secure the satisfactory completion thereof. The Consultant agrees to comply with all federal, state, and municipal laws, rules, and regulations that are now effective or become applicable within the terms of this Agreement to the Consultant's business, equipment, and personnel engaged in operations covered by this Agreement or accruing out of the performance of such operations.

### **XII. Consultant to Maintain Records to Support Independent Contractor Status**

On the effective date of this Agreement (or shortly thereafter), the Consultant shall comply with all federal and state laws applicable to independent contractors including, but not limited to the maintenance of a separate set of books and records that reflect all items of income and expenses of the Consultant's business, pursuant to the Revised Code of Washington (RCW) Section 51.08.195, as required to show that the services performed by the Consultant under this Agreement shall not give rise to an employer-employee relationship between the parties which is subject to RCW Title 51, Industrial Insurance.

### **XIII. Work Performed at the Consultant's Risk**

The Consultant shall take all precautions necessary and shall be responsible for the safety of its employees, agents, and sub-consultants in the performance of the work hereunder and shall utilize all protection necessary for that purpose. All work shall be done at the Consultant's own risk, and the Consultant shall be responsible for any loss of or damage to materials, tools, or other articles used or held by the Consultant for use in connection with the work.

### **XIV. Non-Waiver of Breach**

The failure of the City to insist upon strict performance of any of the covenants and agreements contained herein, or to exercise any option herein conferred in one or more instances shall not be construed to be a waiver or relinquishment of said covenants, agreements, or options, and the same shall be and remain in full force and effect.

### **XV. Resolution of Disputes and Governing Law**

Should any dispute, misunderstanding, or conflict arise as to the terms and conditions contained in this Agreement, the matter shall first be referred to the City Engineer and the City shall determine the term or provision's true intent or meaning. The City Engineer shall also decide all questions which may arise between the parties relative to the actual services provided or to the sufficiency of the performance hereunder.

If any dispute arises between the City and the Consultant under any of the provisions of this Agreement which cannot be resolved by the City Engineer's determination in a reasonable time, or if the Consultant does not agree with the City's decision on the disputed matter, jurisdiction of any resulting litigation shall be filed in Pierce County Superior Court, Pierce County, Washington. This Agreement shall be governed by and construed in accordance with the laws of the State of Washington. The non-prevailing party in any action brought to enforce this Agreement shall pay the other parties' expenses and reasonable attorney's fees.



## **XVI. Written Notice**

All communications regarding this Agreement shall be sent to the parties at the addresses listed on the signature page of the agreement, unless notified to the contrary. Unless otherwise specified, any written notice hereunder shall become effective upon the date of mailing by registered or certified mail, and shall be deemed sufficiently given if sent to the addressee at the address stated below:

CONSULTANT  
Gary D. Letzring, P.L.S.  
PriZm Surveying Inc.  
PO Box 110700  
Tacoma, Washington 98411  
(253) 404-0983

David Brereton  
Director of Operations  
City of Gig Harbor  
3510 Grandview Street  
Gig Harbor, Washington 98335  
(253) 851-6170

## **XVII. Assignment**

Any assignment of this Agreement by the Consultant without the written consent of the City shall be void. If the City shall give its consent to any assignment, this paragraph shall continue in full force and effect and no further assignment shall be made without the City's consent.

## **XVIII. Modification**

No waiver, alteration, or modification of any of the provisions of this Agreement shall be binding unless in writing and signed by a duly authorized representative of the City and the Consultant.

## **XIX. Entire Agreement**

The written provisions and terms of this Agreement, together with any Exhibits attached hereto, shall supersede all prior verbal statements of any officer or other representative of the City, and such statements shall not be effective or be construed as entering into or forming a part of or altering in any manner whatsoever, this Agreement or the Agreement documents. The entire agreement between the parties with respect to the subject matter hereunder is contained in this Agreement and any Exhibits attached hereto, which may or may not have been executed prior to the execution of this Agreement. All of the above documents are hereby made a part of this Agreement and form the Agreement document as fully as if the same were set forth herein. Should any language in any of the Exhibits to this Agreement conflict with any language contained in this Agreement, then this Agreement shall prevail.

IN WITNESS WHEREOF, the parties have executed this Agreement on this \_\_\_\_\_ day of \_\_\_\_\_, 200\_\_.

By: CONSULTANT  
  
Its Principal

CITY OF GIG HARBOR  
By: \_\_\_\_\_  
Mayor

Notices to be sent to:  
CONSULTANT  
Gary D. Letzring, P.L.S.  
PriZm Surveying Inc.  
PO Box 110700  
Tacoma, Washington 98411  
(253) 404-0984

David Brereton  
Director of Operations  
City of Gig Harbor  
3510 Grandview Street  
Gig Harbor, Washington 98335  
(253) 851-6170

APPROVED AS TO FORM:  
  
\_\_\_\_\_  
City Attorney

ATTEST:  
\_\_\_\_\_  
City Clerk

STATE OF WASHINGTON )  
 ) ss.  
COUNTY OF PIERCE )

I certify that I know or have satisfactory evidence that GARY LETZERING is the person who appeared before me, and said person acknowledged that (he/she) signed this instrument, on oath stated that (he/she) was authorized to execute the instrument and acknowledged it as the VICE-PRESIDENT of PRIZM SURVEYING Inc., to be the free and voluntary act of such party for the uses and purposes mentioned in the instrument.

Dated: SEPT 20, 2007



REBEL L. ANDERSON

(print or type name)

NOTARY PUBLIC in and for the  
State of Washington, residing at:

TACOMA

My Commission expires: 11.05.08

STATE OF WASHINGTON        )  
  ) ss.  
COUNTY OF PIERCE         )

I certify that I know or have satisfactory evidence that Charles L. Hunter is the person who appeared before me, and said person acknowledged that he signed this instrument, on oath stated that he was authorized to execute the instrument and acknowledged it as the Mayor of Gig Harbor to be the free and voluntary act of such party for the uses and purposes mentioned in the instrument.

Dated: \_\_\_\_\_

\_\_\_\_\_

\_\_\_\_\_  
(print or type name)

NOTARY PUBLIC in and for the  
State of Washington, residing at:

\_\_\_\_\_  
My Commission expires: \_\_\_\_\_

## Exhibit A

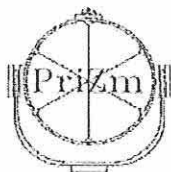

**PRIZM**  
SURVEYING INC.

P.O. Box 110700  
Tacoma, WA 98411  
Office: 253-404-0983  
Fax: 253-404-0984  
ablaisdell@prizmsurveying.com

Mr. David Brereton, Director of Operations  
City of Gig Harbor  
3510 Grandview Street  
Gig Harbor, WA 98335

August 15, 2007

Re: Aquatic Lease Survey (Scofield Site Parcel No(s) 02-21-06-4-039 and 02-21-06-4-043) for D.N.R. Application.

Dear Mr. Brereton,

Prizm Surveying is pleased to provide you with this proposal for Surveying Services. The following is our proposed scope of work.

### Task 1 – Aquatic Lease Survey:

1. Perform office research of the City of Gig Harbor's, Pierce County's and the Department of Natural Resources Records for relevant monumentation, Right of way, Tideland, Lease and Control surveys in the vicinity of the proposed lease area.
2. Perform a random field traverse survey locating relevant monumentation as recoverable through a diligent search and access to monumentation.
3. Perform mathematical computations, and analyze the record boundaries, easements and restrictions as disclosed, which may benefit or burden those portions of the proposed lease area.
4. Field traverse and survey the property lines and proposed lease lines, locating all accessible evidence of possession within 10 feet of said line locations. All Driveways, walks, buildings, bulkheads, docks and visible utility crossings across the subject area will also be located. *Encroachments, if any, will be located; and noted on the final survey. The resolution of any possible encroachments is the responsibility of the city.*
5. Identify the Gov't meander line, tide lines and the harbor lines.
6. Prepare lease area legal descriptions and check for closure.
7. Reduce field notes, plot data obtained from the fieldwork, and prepare an AutoCAD drawing of the above at a convenient scale showing the data collected. Verify that items required by DNR are shown or identified on the drawing. The RECORD OF SURVEY drawing will be reviewed and certified by a Professional Land Surveyor. Provide paper copies to the City of Gig Harbor for your review.
8. Make any corrections as desired by the City. Finalize the drawing for submittal with the Department of Natural Resources.
9. Make corrections, if any, as required by the Department of Natural Resources - Aquatics Division.
10. Record the final drawing with the Pierce County Auditor.

PriZm Surveying, Inc  
August 15, 2007  
Page 2

This estimate is based on the project proceeding in an expeditious manner and may not reflect the time needed by the city and/or State Department of Natural Resources for review. Prizm Surveying does not guarantee that the project will be approved and will not be held liable for project non-approval.

The scope of this survey is based on reasonable and immediate access for field personnel to enter the site and improvements related to this lease survey. If access is denied, the total estimated cost could increase depending on the time required to complete this project.

Specifically excluded from our described scope of services are geotechnical studies, wetland or traffic studies, landscaping, or any engineering services.

All survey related data, field and/or office, as it relates to this project, is the property of Prizm Surveying, Inc and is not to be used, in whole or in part, for any project without written authorization of Prizm Surveying, Inc.

Prizm Surveying will send you an invoice each month for work in progress. In the event your invoices are not paid according to the terms of the contract, your project will not receive priority scheduling until payment arrangements are made. Prizm Surveying will require that; at the completion of the above described tasks, full payment for the task shall be collected prior to proceeding.

The Client will pay all costs of title reports, filing fees, and other governmental fees and assessments not specifically identified within this proposal.

The costs outlined in this proposal are an estimate only, based on the circumstances presented by you and perceived by Prizm Surveying at the time of contract preparation. They are not a guarantee that the costs will not exceed the amount of this estimate. Prizm Surveying is hereby authorized to exceed the estimated costs by up to ten percent without prior written notice to the Client if circumstances encountered in the performance of Prizm's obligations result in an overrun.

The total estimated cost could vary depending on the time required to complete this project due to governmental or construction delay or if the project is put on hold at your request. If the completion of the services outlined in this document exceeds 4 months, this contract is subject to modification in accordance with Prizm's most current hourly rates.

Prizm Surveying will perform additional services beyond the basic scope of work upon your request. No extra work will be undertaken without your prior authorization. Revisions to work completed or in progress, requested by you or your agents through no fault of Prizm Surveying, will be considered extra services for which additional compensation is due. If you require a written proposal and authorization for additional services, this should be addressed at the time the work is requested.

PROJECT COST ESTIMATE

<u>Task</u>	<u>Estimated Cost</u>
<u>Task 1, Initial Research and Lease Survey Map</u>	\$19,750.00
<b>TOTAL ESTIMATED COST</b>	<b>\$19,750.00</b>

\*\*\*\*Other costs, such as governmental fees, reimbursable expenses, and design changes, are not included in this cost estimate.

Any part of this proposal is negotiable pending your particular survey requirements. We look forward to working with you, and if you have any questions or comments regarding this proposal, please call me at (253) 404-0983.

Sincerely,

Aaron B. Blaisdell, P.L.S.  
Member:  
Land Surveyor's Association of Washington,  
National Society of Professional Land Surveyors,  
American Congress on Surveying and Mapping

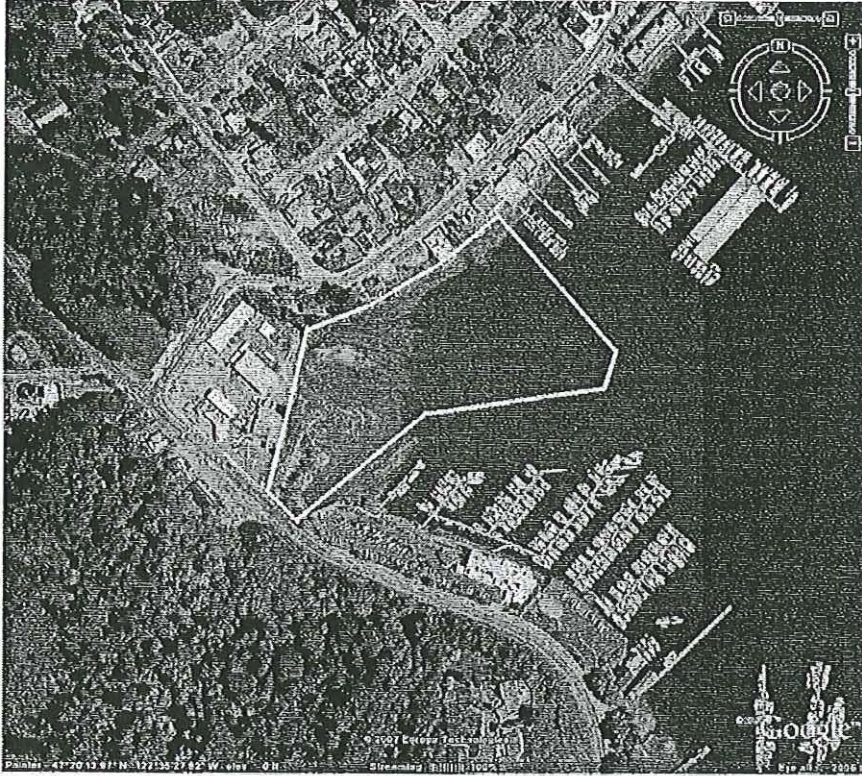





Business of the City Council  
City of Gig Harbor, WA

NB-3

**Subject: Mayor and City Council Compensation (Salaries & Benefits)**

**Dept. Origin:** Administration

**Prepared by:** Rob Karlinsey

**For Agenda of:** October 8, 2007

**Exhibits:** Ordinance  
Compensation Survey

**Proposed Council Action:**

First Reading: Consider an ordinance that would increase compensation (salary & benefits) for the Mayor and City Council.

Initial & Date

**Concurred by Mayor:** \_\_\_\_\_

**Approved by City Administrator:** RSK 10/4/07

**Approved as to form by City Atty:** \_\_\_\_\_

**Approved by Finance Director:** \_\_\_\_\_

**Approved by Department Head:** \_\_\_\_\_

Expenditure	Amount	Appropriation
Required: See fiscal note below	Budgeted: See below	Required: See below.

**INFORMATION / BACKGROUND**

Due to population growth combined with the City's increasing role as a regional service center and commercial hub, demands on the City's elected officials' time and involvement has increased dramatically. Various meetings, including special Council meetings, Council committee meetings, and other meetings has increased substantially in recent years. Therefore, the City Administrator recommends that the Mayor and City Council be compensated for their increased time and resources that they contribute to the City.

A salary increase to \$700 per month per Councilmember (currently \$254/mo.) and \$1,600 per month for the Mayor (currently \$923/mo.) is recommended and is in keeping with jurisdictions of similar size, budget, and/or workload. This proposed salary increase would go into effect on January 1, 2008 for those Councilmembers elected on or after November 6, 2007. Only three of the seven Council positions are up for election this year, so only those three positions would realize the salary increase in 2008. The other four positions and the Mayor would not realize the increase until 2010 (unless a Councilmember or Mayor was appointed before 2010). A cost of living increase of 3% per year, starting in 2009, is also included in the proposal.

In addition to a salary increase and for the same reasons, it is recommended that the City Council receive health insurance benefits starting in 2010. Under this proposal a minimum monthly health allowance and a maximum monthly contribution limit would be established whereby the City would pay for health insurance (medical, dental, and vision). The City would

pay 100% of the Councilmembers' health insurance premiums up to a minimum allowance. For every insurance premium dollar above the minimum allowance, the City would pay 90% of the premium until the City's total payment reached the contribution limit. Any premium beyond the City contribution limit would be paid 100% by the Councilmember.

For Councilmembers whose total premiums would fall below the minimum allowance, the Councilmember could take the difference as cash or roll it into a deferred compensation retirement plan or tax-sheltered health savings plan (if such plans are offered by the City).

### **FISCAL CONSIDERATION**

The increase in salaries will have an impact on the budget of approximately \$41,210 in 2008, and this impact would increase by 3% per year thereafter. This increase is included in the Mayor's preliminary budget proposal.

The added Councilmember health insurance benefit in 2010 would cost approximately \$101,000 in 2010, depending on health insurance rate increases and whether Councilmembers enroll dependents.

### **BOARD OR COMMITTEE RECOMMENDATION**

None.

### **RECOMMENDATION / MOTION**

**Move to:**     **First Reading.** Consider an ordinance that would increase compensation for the Mayor and City Council.

ORDINANCE NO. \_\_\_\_\_

AN ORDINANCE OF THE CITY COUNCIL OF THE CITY OF GIG HARBOR, WASHINGTON, RELATING TO COMPENSATION OF CITY OFFICERS, INCREASING THE SALARIES OF THE MAYOR AND CITY COUNCILMEMBERS, ALLOWING FOR AN AUTOMATIC COST OF LIVING ADJUSTMENT TO THE SALARIES, TO BE EFFECTIVE BEGINNING JANUARY 1, 2008, AND PROVIDING A LIMITED HEALTH ALLOWANCE BENEFIT FOR THE CITY COUNCIL, TO BE EFFECTIVE BEGINNING JANUARY 1, 2010, REPEALING GIG HARBOR MUNICIPAL CODE SECTION 2.40.010 AND 2.40.020 AND ADDING NEW SECTIONS 2.40.010 AND 2.40.010.

---

WHEREAS, compensation for the Mayor and Councilmembers has not been adjusted since 1998; and

WHEREAS, the Mayor's salary in 2007 is \$923 per month and the Councilmembers' salary is \$254 per month; and

WHEREAS, due to population growth combined with the City's increasing role as a regional service center and commercial hub, demands on the City's elected officials' time and involvement has increased dramatically; and

WHEREAS, various meetings, including special Council meetings, Council committee meetings, and other meetings has increased substantially in recent years; and

WHEREAS, the Mayor and City Council should be compensated for the increased time and resources that they contribute to the City; and

WHEREAS, the City's SEPA Responsible Official issued a threshold determination of EXEMPT for this Ordinance on October 8, 2007; NOW, THEREFORE,

THE CITY COUNCIL OF THE CITY OF GIG HARBOR, WASHINGTON, ORDAINS AS FOLLOWS:

**Section 1.** Section 2.40.010 of the Gig Harbor Municipal Code is hereby repealed.

**Section 2.** A new Section 2.40.010 is hereby added to the Gig Harbor Municipal Code, which shall read as follows:

**2.40.010 Salaries and Cost of living adjustments for the Mayor and Council members.**

A. Effective January 1, 2008, salaries for the Mayor and City Council members who have been elected to or appointed to office on or after November 6, 2007, shall be as follows:

Mayor:	\$1,600 per month
Council Member:	\$700 per month

B. On January 1, 2009, and on January 1st of every year thereafter, salaries for the Mayor and City Council members who have been elected or appointed to office on or after November 6, 2007, shall be increased by three percent.

**Section 3.** Section 2.40.020 of the Gig Harbor Municipal Code is hereby repealed.

**Section 4.** A new Section 2.40.020 is hereby added to the Gig Harbor Municipal Code, which shall read as follows:

**2.40.020. Limited health allowance benefit for City Council members.**

A. Effective January 1, 2010, City Council members who have been elected to or appointed to office on or after November 6, 2007, shall be eligible for the following benefits:

1. Full participation in any health, dental and vision insurance plans offered by the City's health plan providers; provided, that there will be a City monthly minimum health allowance and a total contribution limit for each City Councilmember. Participation by the City Council members in health, vision and dental insurance programs is contingent upon meeting all underwriting conditions imposed by the carriers including minimum group participation rates.

2. Effective January 1, 2010, the monthly minimum health allowance for Councilmembers who have been elected to or appointed to office on or after November 6, 2007, shall be \$800. The City will pay 100% of the medical, dental, and vision insurance premiums up to the minimum health allowance. If a Councilmember enrolls a spouse and/or dependents in the City's medical, dental, or vision plans, and doing so causes the total premium to exceed the minimum health allowance, the City will pay 90 percent of the premium amount over the minimum health allowance, up to a total City contribution limit of \$1,800 per month per Councilmember. Each Council member will be responsible, via payroll deductions, for 10 percent of their own premiums over the minimum health allowance and 100 percent of their own premiums exceeding the total City contribution limit. If a Councilmember's medical, dental, and vision insurance premiums are below the minimum health allowance, the Councilmember may elect to take the difference as cash or allocate a

portion to a 457 Deferred Compensation Retirement Plan or a tax-sheltered health savings plan (if such plans are offered by the City).

3. Effective January 1, 2011, and on January 1<sup>st</sup> of every year thereafter, the minimum monthly health allowance for Councilmembers who have been elected or appointed to office on or after November 6, 2007, shall increase by the lesser of 20 percent or the actual dollar amount of the employee plus spouse medical/dental/vision monthly premium increase. Effective January 1, 2011, and on January 1<sup>st</sup> of every year thereafter, the monthly total City contribution limit shall increase by the lesser of 20 percent or the actual dollar amount of the full family (employee, spouse, and two children) medical/dental/vision premium increase. If the City offers more than one medical, dental, or vision plan, the health allowance and contribution limit dollar increase calculation will assume the plan(s) with the higher premium for that year in which the minimum allowance and total contribution limit will apply.

4. In the event the Councilmembers demonstrate proof of comparable medical coverage to that offered by the City through another health insurance plan, or if less than four of the seven Council members choose to participate in the City's medical plan, then Council members may choose to take all or a portion of the monthly minimum health allowance as cash or allocate a portion to a 457 Deferred Compensation Retirement Plan or retiree health savings plan (if such plans are offered by the City).

Section 5. Severability. If any section, sentence, clause or phrase of this Ordinance is held to be invalid or unconstitutional by a court of competent jurisdiction, such invalidity or unconstitutionality shall not affect the validity or constitutionality of any other section, clause or phrase of this Ordinance.

Section 6. Effective Date. This Ordinance shall be published after passage. Sections 1, 2, and 3 of this Ordinance shall be in effect beginning January 1, 2008. Section 4 of this Ordinance shall be in effect beginning January 1, 2010.

PASSED by the City Council and approved by the Mayor of the City of Gig Harbor this \_\_\_ day of \_\_\_\_\_, 200\_\_.

CITY OF GIG HARBOR

\_\_\_\_\_  
CHARLES L. HUNTER, MAYOR

ATTEST/AUTHENTICATED:

By: \_\_\_\_\_  
MOLLY TOWSLEE, City Clerk

APPROVED AS TO FORM:  
OFFICE OF THE CITY ATTORNEY

By: \_\_\_\_\_  
CAROL A. MORRIS

FILED WITH THE CITY CLERK: 10/4/07  
PASSED BY THE CITY COUNCIL:  
PUBLISHED:  
EFFECTIVE DATE:  
ORDINANCE NO:

# Mayor and Councilmember Compensation Survey 2007

## Salary

City	Mayor	Council Member
Bremerton (35,910)	\$8518/month	\$1000/month
Port Orchard (8,310)	\$1397/month	\$386/meeting, 2 meetings/month
University Place (31,140)	\$1500/month	\$1288/month
Lakewood (59,000)	\$900/month	\$700/month
Fircrest (6,260)	\$100/month, plus \$150/regular meeting, \$50/special meeting	\$100/month, plus \$100/regular meeting \$50/special meeting
Puyallup (36,360)	\$1210/month	\$875/month
Sumner (9,025)	\$1,800/month	\$750/month
Steilacoom (6,200)	\$750/month	\$300/month
Gig Harbor (6,765)	\$923/month	\$254/month

## Benefits

City	Mayor	Council Member
Bremerton (35,910)	Mayor receives benefits and Council does not. City does not pay for retirement beyond the Federal requirement. The Mayor has a choice of Group Health	

or KPS for Medical. Delta Dental for Dental and VSP for Vision.

Port Orchard (8,310)	Mayor receives benefits and Council does not. Mayor pays a percentage of premiums with the City paying the majority percentage. No retirement beyond Federal requirement. The mayor has the same options for medical that employees have through AWC.
University Place (31,140)	Full Health Insurance for Mayor & Council members – Medical, Dental and Vision. Min-max health allowance whereby City pays 100% of employee only premiums and 90% of dependent medical premiums.
Lakewood (59,000)	Social Security Replacement (Don't pay in to SS) Long-term Disability Standard Life Insurance Survivor Life Insurance
Fircrest (6,260)	No Benefits
Puyallup (36,360)	Mayor and Council: \$50,000 AD&D Insurance plus \$1,000 for spouse and each dependant. 100% of the Health Care accrual rates for full-family coverage. (medical, dental and vision)
Sumner (9,025)	No Benefits
Steilacoom (6,200)	Opportunity to participate in state PERS. (not required)
Gig Harbor (6,765)	No Benefits





**Business of the City Council  
City of Gig Harbor, WA**

**Subject: Staff Report:  
Green Building/Sustainable Development**

**Proposed Council Action: Information only**

**Dept. Origin: Building and Fire Safety**

**Prepared by: Bower** *[Signature]*

**For Agenda of: October 10, 2007**

**Exhibits:**

Initial & Date

**Concurred by Mayor:** CLH 10/3/07  
**Approved by City Administrator:** ADK 10/3/07  
**Approved as to form by City Atty:** \_\_\_\_\_  
**Approved by Finance Director:** \_\_\_\_\_  
**Approved by Department Head:** Dane 10/3/07

Expenditure Required	0	Amount Budgeted	0	Appropriation Required	0
----------------------	---	-----------------	---	------------------------	---

**INFORMATION / BACKGROUND**

Green, or sustainable, building and low impact development are rising stars in the development and construction industries. The purpose of this report is to provide you with some general information on statewide and regional green building and sustainable development programs and potential opportunities for the City to promote this type of development.

In general, green building and sustainable development programs are designed to provide buildings and developments that take an environmentally friendly approach to development. In the case of sustainable development, the State department of Ecology web site stresses the importance of storm water management, maintenance of water quality, ground water recharge, and limiting erosion and siltation in development activities. Green building, on the other hand focuses more on creating safe, healthy structures that operate efficiently, save energy and resources, protect the environment, and ultimately save the owner and occupants money.

The general strategies of most green building/sustainable development programs currently in effect in the state include such things as:

- Developing sites to preserve natural water flows
- Reducing construction waste
- Designing buildings and using equipment and materials that support good indoor air quality and efficient use of natural and energy resources.

There are two main types of programs currently being promoted in the state's construction industry. One, the Leadership in Energy and Environmental Design, or LEEDS program developed by the U.S.Green Building Council, applies to both residential and commercial construction, though because of the program parameters it is predominantly being applied to commercial work at this time. LEEDS has received acceptance at the State level and is referred to under RCW 39.35D030, Standards for Major Facility Projects, which mandates a level of LEEDS certification for construction of state funded building projects over 5,000 sq. ft is floor area.

Some LEEDS ideals have also been incorporated into the Evergreen Sustainable Development Standard developed in part by the Dept. of Community, Trade and Economic Development in response to the requirements of RCW 39.35D.080 for sustainable development in state supported affordable housing projects. By law, this program will go into effect on or before July 1, 2008.

The other program, Built Green™ Washington, is a project of the state Department of Ecology and is actually a cooperative of regional green home building programs administered by many of the state's regional home builder/master builders associations. These programs are voluntary partnerships whereby builders use a checklist of applicable features and techniques developed by the association and in line with accepted state program guidelines to achieve a green building designation. Typical partners include the building and development industry, state and local government, manufacturers/suppliers, utilities, lenders, and related non-profit organizations. Built Green™ programs are currently in use or development around the state in areas ranging from Pierce, Kitsap, King, Clallam, and Clark Counties on the west side to Spokane, the Tri-Cities, and lower Columbia areas on the east.

The Pierce Co. program, administered by the Tacoma-Pierce Co. Master Builders Assn. was established in 2003 under a partnership of the MBA, DOE, Puget Sound Energy, and the City of Tacoma. This program is a "market driven" program in that contractors are encouraged to become involved by market conditions and consumer preferences rather than through regulation.

Tacoma-Pierce Co. MBA's Built Green™ program, which has modules for home builders, remodelers, land developers, and multi-family builders, provides the technical criteria for rating green building and sustainable development techniques as check lists of action items to be addressed during construction. Each activity is given a point value, the sum of which result in a "Star" rating of between 1 and 5, with 5 being the highest level recognized by the program. The action items focus on such things as:

- Energy efficient insulation, glazing, appliances, fans etc.
- Building materials from sustainable sources including the use of recycled products, use of oriented strand board and engineered wood products, and products from sustainable resources such as bamboo, cork, concrete and similar products.
- Preservation of open space during design and development of housing projects including techniques to minimize disruption of existing vegetation and preserving natural water drainage on the site.
- Air infiltration concerns such as sealing of building openings, and use of high efficiency HVAC equipment.

Participating builders/developers in the program:

- Participate in a voluntary self-certification rating system for plats, new homes and remodel construction demonstrating that they meet standards that exceed the regulatory requirements.
- Work in partnership to create safer, healthier, more efficient homes while reducing construction and development impacts and improving and protecting community and natural resources.
- Members receive an orientation to the program, education, access to local and national resources and approval to use the Built Green™ designation in their marketing efforts.

The program was developed in consultation with stakeholders including building contractors, developers, the MBA, Tacoma Solid Waste Division, Puget Sound Energy, Tacoma Public Utilities, the WSU cooperative extension service, the state Dept. of Ecology, The City of Tacoma and Fannie Mae. Many of these stake holders continue to be involved as partners or sponsors of the program, and the MBA continues to seek support from governmental and non-governmental sources. At this time they are working with the City of Puyallup in an effort to enlist the City's participation and support.

Should the City of Gig Harbor desire to promote green building and sustainable development within the City limits, there are a number of avenues through which we can be involved. The City can choose to support the MBA program through a resolution endorsing the program. Other options include providing funding or in-kind support to the program, participation in the programs steering committee, and/or developing incentives to promote green building and sustainable development in the community.

Examples of incentives currently offered by King County include:

- A "Green Track" for permitting where knowledgeable staff members offer assistance to applicants on sustainable development techniques.
- Customized review schedules that include an assigned staff "project manager" at no extra charge for projects achieving a 5-star rating.
- Free green building technical consulting by appointment.
- Cost sharing and fee discounts for the use of low impact development best management practices.
- Providing for product displays in the permit center lobby.

At first glance, many of these incentives are within the City of Gig Harbor's capabilities and in fact would complement our existing programs with minor modifications. Such things as pre-application and permit fee reductions for green building / sustainable development projects meeting certain criteria are possible with Council approval. Space could be made for product displays in the cases or lobby of the Civic Center. And the current "team approach" model to staff assignments to projects could be modified to provide green building/sustainable development expertise. Additionally, options could be explored that would provide for density adjustments, "skinny streets", or other similar incentives to encourage sustainable developments and the use of green building techniques.

## **FISCAL CONSIDERATION**

There is no fiscal impact associated with this staff report. Fiscal concerns would need to be addressed should the City desire to move ahead with some type of green building/sustainable development program. These could range from no fiscal impact for a resolution of endorsement of the Built Green™ program or of green building/sustainable development projects in general, to reduced fee income from monetary incentives and additional training costs necessary to bring staff up-to-speed with green building/sustainable development practices.

## **BOARD OR COMMITTEE RECOMMENDATION**

None

## **RECOMMENDATION / MOTION**

Staff recommends that the City consider green building and sustainable development as an emerging, and desirable trend in the development and construction industries and incorporate environmentally friendly development encompassing both disciplines in any future discussions about sustainable community activities. Staff would also recommend exploring opportunities to support the current MBA program including a resolution of support for the program and involvement in the steering committee should that opportunity become available.

### **Move to:**

This staff report is for informational purposes only. No motion is requested at this time.



Business of the City Council
City of Gig Harbor, WA

Subject: Staff Report – Comprehensive Plan
Neighborhood Design Areas

Proposed Council Action:
Review

Dept. Origin: Planning

Prepared by: Tom Dolan

Handwritten signature of Tom Dolan

For Agenda of: October 8, 2007

Exhibits: Draft Neighborhood Design Area
Map

Initial & Date

Concurred by Mayor:

Handwritten initials and date: CHH 10/3/07

Approved by City Administrator:

Handwritten initials and date: RBK 10/3/07

Approved as to form by City Atty:

Blank line for signature

Approved by Finance Director:

Handwritten initials and date: Dune 10/3/07

Approved by Department Head:

Handwritten initials and date: Dune 10/3/07

Table with 4 columns: Expenditure Required, Amount Budgeted, Appropriation Required, and a final column with value 0.

INFORMATION / BACKGROUND

The Planning Commission's 2007 work program (which was approved by the City Council) included a major effort to improve the design review process. The Planning Commission and the Design Review Board have been meeting jointly since February to identify and develop several needed text amendments that simplify and streamline the design review process. The needed code amendments were identified as Phase 1 of the overall effort. To date, a number of code amendments have been adopted by the City Council. These code amendments have already had a significant positive effect on the design process.

Phase 2 was identified in the initial stages of the project as the development of needed amendments to the City's Comprehensive Plan which would address additional process improvements. One of the goals of Phase 2 was to examine whether or not the design review standards need to be the same throughout the City. Concern was expressed at an early stage that the existing design standards were originally developed for the view basin and that not all of the standards were appropriate for every area of the City. For example, requiring commercial buildings to be located to the front property line might be appropriate for the downtown area but that same standard may not be appropriate for the west side commercial or Gig Harbor North. Another example affects the employment districts. Questions have been raised as to whether the same design requirements for building modulation and materials should be applied to both warehouses and commercial buildings.

The Planning Commission and Design Review Board considered these issues at several meetings. At this point, their proposal has been to designate 8 neighborhood design areas

within the City and the adjacent Urban Growth Area. Copies of the draft neighborhood design areas map are attached. It is important to understand that the boundaries on the map are in draft form and that under further study they may change. One potential result of the development of the 8 neighborhood design areas could be the development of area specific design standards that are consistent with the desired character for the area.

The draft neighborhood areas are tentatively designated as: Soundview, View basin, Rosedale/Hunt, Westside, Peacock Hill, Gig Harbor North, Purdy and the Employment District.

The Planning Commission is scheduled to hold a public hearing on all of the 2007 Comprehensive Plan Amendments on Thursday, October 18. Over 4,000 postcards advertising the public hearing have been mailed out and a large advertisement will be placed in the Gateway newspaper. One of the amendments is the designation of neighborhood design areas. It is anticipated that there will be a substantial discussion of the proposal at the public hearing. The Planning Commission is scheduled to forward their final recommendations on the 2007 Comprehensive Plan Amendments to the City Council in November. Additional opportunity for public input will be available during the City Council's consideration of the amendments.

**FISCAL CONSIDERATION**

None

**BOARD OR COMMITTEE RECOMMENDATION**

N/A

**RECOMMENDATION / MOTION**

None/Informational Purposes Only

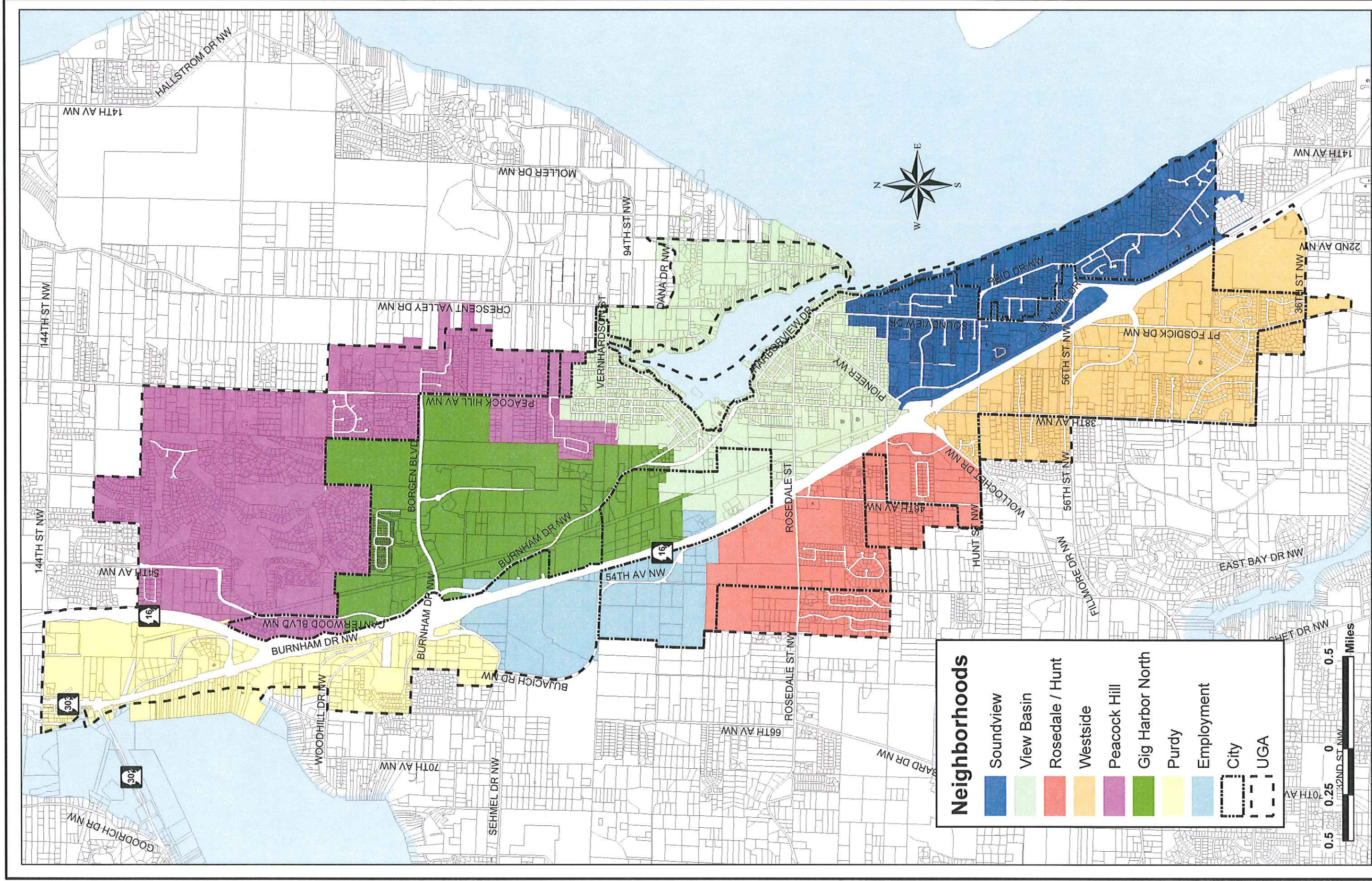

**Neighborhoods**

- Soundview
- View Basin
- Rosedale / Hunt
- Westside
- Peacock Hill
- Gig Harbor North
- Purdy
- Employment
- City
- UGA



City of Gig Harbor  
Comprehensive Plan

# Draft Neighborhoods



Date: October 3, 2007  
To: Mayor and City Council  
From: Rob Karlinsey, City Administrator   
Subject: PenMet Youth Athletic Facilities Grant

Recently, PenMet approached us and asked the City to apply for a State Youth Athletic Facilities (YAF) grant on their behalf. Under current YAF rules, special purpose districts like PenMet are not allowed to apply for YAF grants (cities and non-profits are allowed).

As a result, PenMet is asking the City to apply for a YAF grant on their behalf. The grant would help fund ball fields at the new Homestead Park. Because the City of Gig Harbor does not have an abundance of its own ball fields, I believe it is in our citizens' interest to help adjacent jurisdictions like PenMet develop ball fields that residents of both incorporated and unincorporated Gig Harbor can enjoy.

As part of applying for and accepting the YAF, the City will be required to provide a match and also to receive the funds. Therefore, an interlocal agreement with Penmet will be needed in order to guarantee that PenMet will meet the match obligations and that the City will transmit the funding to PenMet.

There will be more details to follow when we come back to the City Council with a proposed interlocal agreement between the City and PenMet.

The City could have applied for its own YAF funding but was not in a good position to do so for the following reasons:

**WESTSIDE NEIGHBORHOOD PARK.** We were advised by Myra Barker, our project manager for the state, that we should not apply for funding until we have built what the state funded in 2007 (\$300,000 for park development). Also, after further investigation, Myra discovered that our added basketball court feature is not eligible under YAF.

**CITY PARK AT CRESCENT CREEK.** Initially, a request to upgrade the irrigation and drainage at City Park included a 50% grant match from PENMET. After meeting with PENMET, they declined funding the project and suggested partnering outside of the YAF grant process to pay for the upgrades. Those discussions are continuing. Part of the challenge is that if PENMET invests in these upgrades, they would like to provide field maintenance that is consistent with their standards for competitive play. This may mean rethinking the City's current policy at City Park which is: no reservations to play and no fees to play. The park currently provides "relaxed" field play to the community.