

# **GIG HARBOR CITY COUNCIL MEETING**



**October 13, 1997**

**7:00 P.M., CITY HALL COUNCIL CHAMBERS**



**AGENDA FOR GIG HARBOR CITY COUNCIL MEETING**  
**October 13, 1997 - 7:00 p.m.**

**CALL TO ORDER:**

**PUBLIC HEARING:** Amendments to Title 17, GHMC; Wireless Communication Facilities.

**APPROVAL OF MINUTES:**

**CORRESPONDENCE / PROCLAMATIONS:**

**OLD BUSINESS:**

1. Second Reading of Ordinance - Planning Commission Recommendation, Amendments to Title 17, GHMC; Wireless Communication Facilities.
2. Second Reading of Ordinance - Collection of Debt.
3. Pioneer Park Rotary Project.

**NEW BUSINESS:**

1. First Reading of Ordinance - Telecommunications, Use of Public Property.
2. Talmo Street Vacation Request.
3. First Reading of Ordinance - Part Time Personnel Benefits.
4. Request for Time Extension - SUB 94-01, Rod Nilsson.
5. Underground Storage Tank Removal - Contract Award.
6. Consolidation of Copier Maintenance Contracts.
7. Liquor License Application - Harbor Humidor.
8. Special Occasion Liquor License - Knights of Columbus.
9. Liquor License Renewals - Bayview Grocery; Gig Pub & Grill; and Olympic Village BP.
10. Discontinued Sales of Liquor - The Captains Mate & The Captains Keep.

**PUBLIC COMMENT/DISCUSSION:**

**MAYOR'S REPORT:**

**COUNCIL COMMENTS:**

**STAFF REPORTS:**

Chief Mitch Barker - GHPD Stats.

**ANNOUNCEMENTS OF OTHER MEETINGS:**

**APPROVAL OF BILLS:**

**EXECUTIVE SESSION:** For the purpose of discussing litigation, potential litigation, and personnel.

**ADJOURN:**



**REGULAR GIG HARBOR CITY COUNCIL MEETING OF SEPTEMBER 22, 1997**

**PRESENT:** Councilmembers Markovich, Picinich, Owel, Platt, Ekberg and Mayor Wilbert.

**CALL TO ORDER:** 7:04 p.m.

**APPROVAL OF MINUTES:**

**MOTION:** Move approval of the minutes of the September 8, 1997 as presented.  
Ekberg/Owel - unanimously approved. Councilmember Platt abstained.

**CORRESPONDENCE/PROCLAMATIONS:** None scheduled.

**OLD BUSINESS:**

1. Second Reading - Adult Entertainment Licensing Ordinance. Howard Jensen, Legal Counsel, explained that this ordinance would govern the licensing of adult cabarets, arcades and other adult facilities.

**MOTION:** Move to adopt Ordinance No. 768.  
Picinich/Markovich - unanimously approved.

**NEW BUSINESS:**

1. First Reading of Ordinance - Planning commission Recommendation, Amendments to Title 17, GHMC: Wireless Communication Facilities. Ray Gilmore, Planning Director, introduced this update to the zoning code in regards to telecommunications standards. He explained that this ordinance was the product of several months of work by the Planning Commission, Legal Counsel, and the Planning Staff to address the requirements of the 1996 Federal Communications Act. He reminded Council that Ordinance No. 739 adopted in October of last year imposed a one-year moratorium on citing of telecommunications facilities in order to allow sufficient time to develop a telecommunications ordinance which would address the citing and location of these facilities. He answered questions and added that there would be a public hearing on this ordinance at the second reading on October 13th, and any changes could be addressed at that time.
2. First Reading of Ordinance - Collection of Debt. Mark Hoppen, City Administrator, explained that the RCWs had been amended to allow collection costs to be added to debt owed to the city, which would should increase the return to the city. He added that this would return for a second reading.
3. Resolution - Setting Charges and Fees for Business Licenses. Mark Hoppen explained that this resolution adjusted the business license fee schedule by adding adult entertainment facilities.

**MOTION:** Move approval of Resolution No. 502.  
Ekberg/Platt - unanimously approved.

4. Employment Contract - Finance Director. Mark Hoppen introduced David Rodenbach and explained that he was the person chosen for the position of Finance Director. He added that he was very happy to have someone with Dave's abilities joining the staff and asked Council's approval of the employment contract.

**MOTION:** Move to approve the attached contract at the starting salary of \$4,399, for the start date of October 1, 1997.  
Owel/Ekberg - unanimously approved.

5. Information Systems Specialist - Job Description and Salary Range. Mark Hoppen presented the job description and salary range for a new position titled Information Systems Specialist. He explained the need to maintain the computer system for the City of Gig Harbor and added that he had studied both in-house and out-source options. He gave an overview of the information that had been obtained and recommended that the best available option was to adopt the new in-house position. Mark explained that Tom Enlow, while acting as Finance Director, had functioned as the network administrator, and that he had saved the city a great deal of money over the years. He asked Council's approval to transfer Tom to the position of Information Systems Specialist on a half-time basis if the position were approved.

**MOTION:** Move to approve the Information Systems Specialist job description, that we direct the Finance Director to adjust the 1997 Budget to account for the new position; that we direct staff to return with a resolution which defines proportional benefits contribution for part-time, regular employees who work less than full-time; and that we direct the City Administrator to transfer Tom Enlow to the Information Systems Specialist position as a .5 FTE regular employee effective October 1, 1997, after adopting Ordinance No. 769, in one reading, to adjust the 1997 salary range to include the Information Systems Specialist position.  
Markovich/ Ekberg -

Councilmember Platt suggested that the city advertise the position and go through the regular hiring process. Mark Hoppen explained that he had the ability to transfer an existing employee to the position without going out to hire, but that he would like to do it with Council's consent. Councilmember Markovich added that Tom Enlow seems to know the computer system and that he would be very helpful during the transition period for the new Finance Director. Councilmember Ekberg agreed and said it was a timely solution.

**RESTATED MOTION:** Move to approve the Information Systems Specialist job description, that we direct the Finance Director adjust the 1997 Budget to account for the new position, that we direct staff to return with a resolution

which defines proportional benefits contribution for part-time, regular employees who work less than full-time; and that we direct the City Administrator to transfer Tom Enlow to the Information Systems Specialist position as a .5 FTE regular employee effective October 1, 1997, after we adopt Ordinance 769 in one reading to adjust the 1997 salary range to include the Information Systems Specialist position.  
Markovich/ Ekberg -

Markovich/ Ekberg - unanimously approved.

6. Contract Award - Pioneer Way Pavement Repair. Mark Hoppen gave a history of the damage to the roadway along Pioneer Way, and presented the contract to repair the damage, recommending it be awarded to the low bidder, Woodworth and Company.

**MOTION:** Move approval of the execution of the contract for the Pioneer Way Pavement Repair to Woodworth & Sons, Inc., in the amount of fourteen thousand, three hundred nineteen dollars and sixty cents (\$14,319.60).  
Picinich/Ekberg - unanimously approved.

7. Contract Award - Bogue Building Painting. Mark Hoppen presented this contract to paint the Bogue Building and recommended awarding the contract to the low bidder, Jones Painting, Inc. Councilmember Markovich asked why the job could not be done by the Public Works Crew. Mark explained that due to the recent annexations, the crew was working at maximum capacity, and could not take on the project without neglecting routine duties.

**MOTION:** Move to authorize the Mayor to execute the contract for the Bogue Building Painting to Jones Painting, Inc., for the amount of two-thousand forty-one dollars and fifty-five cents (\$2,241.55).  
Ekberg/Picinich - unanimously approved.

8. Appointment of Councilmember Ekberg to the DOT Local Improvement Committee for Narrows Bridge. Mayor Wilbert explained that Councilmember Ekberg had volunteered to serve on this committee.

**MOTION:** Move to approve the appointment of elected official Councilmember Ekberg to the Local Improvement Committee.  
Picinich/Markovich - unanimously approved.

9. Re-appointment of Jerry Crutchfield to the Civil Service Board. Mayor Wilbert recommended the re-appointment of Mr. Crutchfield to serve an additional six years on the Civil Service Board.

**MOTION:** Move to approve the re-appointment of Jerry Crutchfield to the Civil Service

Board for an additional six years.  
Ekberg/Picinich - unanimously approved.

10. Liquor License Application - Baskets to Go. No action taken.
11. Special Occasion Liquor License - North American Gymnastic Boosters. No action taken.

**PUBLIC COMMENT:** No one signed up.

**MAYOR'S REPORT:** Cities by Nature's Design.

Mayor Wilbert reported on her recent trip to Atlanta where she attended the conference "Cities by Nature's Design." She said that she discovered that most of the cities in this country are desperate to reforest their cities. She said the City of Gig Harbor does not have this problem, but instead, needs to maintain its existing trees. She encouraged Council to support the training of the public works department in this area and asked if anyone would like to become involved in a view reclamation effort. She shared other information from the conference and donated a red maple tree grown from seeds taken from Mt. Vernon, Virginia, George Washington's home.

**COUNCIL COMMENTS:** None.

**STAFF REPORT:** None scheduled.

**ANNOUNCEMENT OF OTHER MEETINGS:** None announced.

**APPROVAL OF BILLS:**

**MOTION:** Move approval of checks #18385 through #18392 and #18641 through #18728 in the amount of \$246,258.77.  
Owel/Ekberg - unanimously approved.

**EXECUTIVE SESSION:**

**MOTION:** Move to adjourn to Executive Session at 9:00 p.m. for approximately 20 minutes for the purpose of discussing litigation, potential litigation, and property acquisition.  
Picinich/Platt - unanimously approved.

**MOTION:** Move to return to regular session at 9:20 p.m.  
Platt/Picinich - unanimously approved.



**ADJOURN:**

**MOTION:** Move to adjourn at 9:24  
p.m.

Platt/Owel - unanimously approved.

Cassette recorder utilized.  
Tape 470 Side A 387 - end.  
Tape 470 Side B 000 - end.  
Tape 471 Side A 000 - 326.

\_\_\_\_\_  
Mayor

\_\_\_\_\_  
City Clerk





*City of Gig Harbor. The "Maritime City"*

DEPARTMENT OF PLANNING & BUILDING SERVICES  
3125 JUDSON STREET  
GIG HARBOR, WASHINGTON 98335  
(253) 851-4278

**TO: MAYOR WILBERT AND CITY COUNCIL**  
**FROM: PLANNING-BUILDING STAFF**  
**SUBJECT: SECOND READING OF ORDINANCE/PLANNING COMMISSION  
RECOMMENDATION WIRELESS COMMUNICATION FACILITIES  
ORDINANCE – PUBLIC HEARING**  
**DATE: OCTOBER 8, 1997**

### **Background/Introduction**

Attached is the Planning Commissions recommendation on a draft wireless communications ordinance for the City of Gig Harbor. The Planning Commission conducted a series of worksessions in April and May of this year and a public hearing on the draft ordinance on June 5<sup>th</sup>. Comments were received by three representatives of the telecommunication industry. A follow-up worksession was conducted on August 7<sup>th</sup>. Based upon the staff recommendation, testimony received at the public hearing and review by legal counsel, the Planning Commission prepared the submitted draft of the ordinance. Council conducted it's first reading of the ordinance on September 27, 1997.

### **Policy Issues**

On October 28, 1996, the Gig Harbor City Council adopted Ordinance 739 which imposed a one-year moratorium on the siting and location of telecommunications facilities within the city. The moratorium was imposed in order to allow the Planning Commission and City Council sufficient time to develop a telecommunications ordinance which addresses the siting and location of telecommunications facilities throughout the various zoning districts in the city.

The Federal Communications Act of 1996 precludes local government from unduly regulating the siting and construction of personal wireless service facilities (i.e. service systems for pagers, cell phones, etc.). Limitations are established which prohibit local government from unreasonably discriminating amongst providers or which have the effect of prohibiting the provision of personal wireless services. While local zoning authority is maintained, Congress imposed many restrictions on the exercise of this authority. First, cities are prohibited from regulating the environmental effects of radio frequency emissions. Presumably, this refers only to human health effects and not interference with other communications equipment within the vicinity of new or modified facilities. Second, cities may not regulate wireless facilities in such a manner as to prohibit such services. It

appears that a city may not simply ban the siting of wireless communication facilities, and, more likely, that cities must provide for the location of such facilities, either through zoning classifications or special permit process. Finally, cities are prohibited from discrimination against companies which provide equivalent services.

The ordinance recommended by the Planning Commission governs the zoning aspects of telecommunications facilities. The ordinance not only addresses wireless communication facilities but also satellite dish systems, amateur radio towers and broadcast and relay towers. Although these latter facilities are not directly the subject of the Telecommunications Act of 1996, previous federal regulations and state statutes limit local governments' ability to preclude the siting of such facilities.

With the exception of broadcast and relay towers (permitted only in the Employment Districts west of SR-16), the ordinance does not outright prohibit wireless communication facilities within the city. The proposed ordinance emphasizes co-location (attached or grouped with existing facilities) as a preferred siting method. Should that not prove to be a viable option, there is a order of siting preference. Additionally, a proposed facility may require approval by the Hearing Examiner, depending upon the zone in which it is to be located. Council is referred to the General Summary, which shows the order of siting preference.

The standards proposed are deemed reasonable in accomplishing the objectives of meeting state and federal requirements while protecting the public's welfare under through the city's zoning authority. A table which summarizes standards and location requirements is attached.

### **Fiscal Impact**

The ordinance will have negligible impact on the city's financial resources. Appropriate permit review fees will be recommended at the next update of the Fee Resolution so off-set the cost of staff review on applications.

### **Recommendation**

This is the second reading of the ordinance and a public hearing. Following the public hearing, Council may act on the ordinance at this meeting. If Council elects to continue deliberation to a third reading on October 27, staff advises that the moratorium enacted on October 28, 1996, be extended for three weeks. This is to permit sufficient time to provide publication of the summary of the ordinance and to set an effective date prior to expiration of the moratorium.

ORDINANCE NO. \_\_\_\_\_

AN ORDINANCE OF THE CITY OF GIG HARBOR RELATING TO LAND USE AND ZONING, ESTABLISHING SITING STANDARDS FOR AMATEUR RADIO ANTENNAE, SATELLITE DISH ANTENNAE, TELEVISION AND RADIO BROADCAST TOWERS, AND TELECOMMUNICATION FACILITIES REGULATED UNDER THE FEDERAL TELECOMMUNICATIONS ACT OF 1996, ADOPTING DEVELOPMENT STANDARDS, AND PROVIDING FOR SPECIAL EXCEPTIONS AND CONDITIONAL USE PERMITS; ADDING A NEW CHAPTER 17.61; ADDING NEW SECTIONS 17.04.041, 17.04.125, 17.04.225, 17.04.756, 17.04.757, 17.04.758 AND 17.64.046; AMENDING SECTIONS 17.04.055, 17.04.710, 17.45.030 AND 17.64.040 ~~TO~~ OF THE GIG HARBOR MUNICIPAL CODE.

---

WHEREAS, Wireless Personal Communications Services and Wireless Communication Facilities ("WCF") comprise a rapidly growing segment of the utilities and communications sector and have merit and value for the community and region as a whole; and,

WHEREAS, ~~growth in the~~ use of wireless communication services has grown 20% to 30% annually on a national basis since 1991, and it is estimated that half of the number of households will have wireless services by the Year 2000; and,

WHEREAS, wireless communication services contribute to the public health, safety and welfare in that they provide emergency services communications in the event of accidents and natural disasters; and,

WHEREAS, the FCC requires license holders to provide services to areas within certain, limited time frames where wireless communications licenses have been acquired; and

WHEREAS, ~~WCFs~~ wireless communications facilities are required to provide quality communication services to meet the growing needs of the public and businesses for wireless communication services ~~and;~~ and

WHEREAS, wireless communication services should be accommodated ~~just as infrastructure for utilities has been accommodated;~~ and, by the City just as the City has accommodated infrastructure for other utilities; and

WHEREAS, the Federal Tele-communications Act of 1996 preserves local authority regarding zoning issues related to wireless communication services ~~where~~ as long as local jurisdictions do not unreasonably discriminate among all the service providers, i.e., allowing one or two carriers to provide service rather than all who are in the market ~~and that;~~ and

WHEREAS, the Tele-communications Act allows each jurisdiction ~~must~~ to determine how much regulation, if any, is necessary; and,

WHEREAS, the current zoning code of the City of Gig Harbor was adopted before wireless communication facilities were anticipated, and therefore, appropriate siting and development standards do not exist; and,

WHEREAS, the Gig Harbor Code also does not address other types of communication facilities not regulated under the 1996 Tele-communications Act such as amateur (HAM) radio and satellite dish antennae; and,

WHEREAS, on October 28, 1996, the Gig Harbor City Council adopted Ordinance No. 739, ~~and~~ which declared a moratorium on the siting of wireless and tele-communications facilities for a period not to exceed one year, in order to allow City staff

sufficient time and resources to develop the necessary standards to address telecommunication and wireless communications facilities; and,

WHEREAS, the City Planning Commission held various workshop meetings on the subject of tele-communications, and on June 5, 1997, a public hearing was held on a draft ordinance; and

WHEREAS, the Planning Commission acknowledges that the City Zoning Code (Title 17 GHMC) establishes 19 specific zoning districts, consisting of 7 Residential districts, 8 Commercial and Employment Districts, 3 Waterfront districts and a Public-Institutional district; and,

WHEREAS, the Planning Commission, following its final worksession on August 7, recommends adoption of this ordinance, which describes standards ~~are applied for wireless and telecommunication~~ to be applied to wireless communication services and other types of communication facilities which distinguish between the purely commercial (non-residential) districts from the residential and waterfront (mixed use) districts.

**NOW, THEREFORE, THE CITY COUNCIL OF THE CITY OF GIG HARBOR DO ORDAIN AS FOLLOWS:**

Section

1. A new section 17.04.041 is hereby added to the Gig Harbor Municipal Code, to read as follows:

**17.04.041 Amateur radio tower** means an antenna and tower which transmits non-commercial communication signals and is licensed as an amateur radio tower by the Federal Communications Commission. Guy wires for amateur radio towers are considered part of the structure for the purposes of meeting development standards.

Section 2. Section 17.04.055 of the Gig Harbor Municipal Code is amended

to read as follows:

~~17.04.055 "Antenna" means a metallic device used for the transmission or reception of electromagnetic waves. This definition does not include satellite dish antenna. is any system of electromagnetically tuned wires, poles, rods, reflecting discs or similar devices used to transmit or receive electromagnetic waves between terrestrial and/or orbital based points; this includes, but is not limited to, radio antenna, television antenna, satellite dish antenna and cellular antenna. Types of antenna include:~~

~~1. Omnidirectional (or "whip") antenna transmits and receives radio frequency signals in a 360 degree radial pattern.~~

~~2. Directional (or "panel") antenna transmits and receives radio frequency signals in a specific pattern of less than 360 degrees.~~

~~3. Parabolic antenna (or "dish") is a bowl shaped device for the reception and/or transmission of communication signals in a specific directional pattern.~~

Antenna means any exterior apparatus designed for telephonic radio, data, Internet or television communications through the sending and/or receiving of electromagnetic waves, and includes equipment attached to a tower or building for the purpose of providing personal wireless services, included unlicensed wireless tele-communications services, wireless tele-communications services utilizing frequencies authorized by the Federal Communications Commission for "cellular," "enhanced"cellular," "enhanced specialized mobile radio," and "personal"personal communications services," "tele-communications" "tele-communications services," and its attendant base station. An "antenna array" is one or more rods, panels, discs or similar devices used for the transmission or reception of radio frequency signals, which may include omni-directional antenna (panel) and parabolic (disc). The antenna array does not include the support structure.

Section 3. A new section 17.04.125 is hereby added to the Gig Harbor

Municipal Code, to read as follows:

**17.04.125 Broadcast and Relay Towers** means a freestanding support structure, attached antenna, and related equipment intended for transmitting, receiving or re-transmitting commercial television, radio, telephone, cellular or other



communication services.

Section 4. A new ~~section 17.04.225~~ Section 17.04.203 is hereby added to the Gig Harbor Municipal Code, to read as follows:

**17.04.203 Cel-site** - A tract or parcel of land that contains wireless service facilities, including any antenna, support structure, accessory buildings and parking, and may include other uses associated with and ancillary to wireless services.

Section 5. A new section 17.04.225 is hereby added to the Gig Harbor Municipal Code, to read as follows:

**17.04.225 Co-location** - The placement and arrangement of multiple antenna and equipment on a single support structure and equipment pad area.

Section 6. A new Section 17.04.554 is hereby added to the Gig Harbor Municipal Code, to read as follows:

**17.04.554 Microcell** means a wireless communication facility consisting of an antenna that is either: (i) four feet (4') in height and with an area of not more than five hundred eighty (580) square inches; or (ii) if a tubular antenna, no more than four inches in diameter and no more than six feet (6') in length.

Section 7. Section 17.04.710 of the Gig Harbor Municipal Code is amended to read as follows:

**17.04.710 Satellite dish antenna** means a circular or parabolically shaped device of solid or mesh construction, designed and erected for receiving telecommunication signals. A small satellite dish antennae is defined as having a diameter of one meter or less and located within any zoning district or two meters or less within commercial and employment districts. A large satellite dish antennae is defined as having a diameter of greater than one meter in diameter in any residential zone or two meters in diameter in commercial and employment districts.

Section ~~6~~ 8. A new section ~~17.04.756~~ 17.04.755 is hereby added to the Gig Harbor Municipal Code, to read as follows:

~~17.04.756~~ 17.04.755 **Wireless communication facility** means any unstaffed facility for the transmission and/or reception of radio frequency (RF) signals through electromagnetic energy usually consisting of an equipment shelter or cabinet, a support tower or other structure used to achieve the necessary elevation, and the transmission and reception devices or antenna.

Section 7 9. A new section ~~17.04.757~~ 17.04.756 is hereby added to the Gig Harbor Municipal Code, to read as follows:

~~17.04.757~~ 17.04.756 **Wireless communications facility (WCF), attached** means an Antenna Array that is attached to an existing building or structure (Attachment Structure), which structures shall include but not be limited to utility poles, signs, water towers, with any accompanying pole of device (Attachment Device) which attaches the Antenna Array to the existing building or structure, transmission cables, and an Equipment Facility which may be located either inside or outside of the Attachment Structure.

Section 8 10. A new Section 17.04.757 is hereby added to the Gig Harbor Municipal Code, to read as follows:

17.04.757 **Wireless Services or Wireless Communication Services** means commercial mobile services, unlicensed wireless services, and common carrier wireless exchange access services, as defined by federal laws and regulations.

Section 11. A new section 17.04.758 is hereby added to the Gig Harbor Municipal Code to read as follows:

17.04.758 **Wireless communications support structure** means a structure designed and constructed specifically to support an Antenna Array (as defined in GHMC 17.04.055), and may include a monopole, self-supporting (lattice) tower, guy-wire support tower and other similar structures. Any device (Attachment Device) which is used to attach an ~~Attached~~ WCF to an existing building or structure (Attachment Structure) shall be excluded from the definition of and regulations applicable to Support Structures.

Section 12. A new chapter 17.61 (Communications Facilities) is hereby added to the Gig Harbor Municipal Code, to read as follows:

## COMMUNICATIONS FACILITIES

### Chapter 17.61

Sections:	17.61.010	Purpose.
	17.61.020	General Guidelines and Permit Regulations.
	17.61.030	Development Standards for all Public Institutional, Residential, Waterfront District and Downtown Business Districts (PI, R-1, R-2, R-3, RB-1, RB-2, PCD-RLD, PCD-RMD, WR, WM, WC, and DB).
	17.61.040	Development Standards for all Commercial Districts (C-1, B-1, B-2, PCD-C, and PCD-BP).
	17.61.050	Siting Standards for Employment Districts (ED).
	17.61.060	Special Exceptions.
	17.61.070	Review by Independent Consultant- Third Party Review.

#### **17.61.010 Purpose**

In addition to implementing the general purposes of the Comprehensive Plan and development regulations, this section addresses the issues of permitting, siting, appearance and safety associated with broadcast and relay towers, amateur radio towers, ~~telecommunications~~ tele-communications monopoles, satellite dish antenna, wireless communications facilities and related equipment. It provides siting opportunities at appropriate locations within the City to support existing communications technologies and to allow adapt to new technologies as needed.

This chapter provides for a wide range of locations and siting options for ~~the provisions for wireless technology which minimizes~~ wireless communications facilities which minimize associated safety hazards and visual impacts ~~sometimes associated with wireless communications facilities.~~ The siting of wireless communication facilities on existing buildings and structures, co-location of telecommunication facilities on a single support structure and visual mitigation strategies are encouraged to preserve neighborhood aesthetics and reduce visual clutter in the community.

#### **17.61.020 General Guidelines and Permit Requirements**

- A. General Guidelines. The development standards in this chapter address setback and other site specific location factors. Siting criteria for ~~broadcast and relay towers and wireless~~ all communication facilities are necessary to encourage ~~the siting of these facilities~~ in the most appropriate

locations based upon land use compatibility, neighborhood characteristics and aesthetic considerations.

B. Priority of locations. ~~Wireless communication facilities and antennae should be located, in a~~ The order of priorities for locating new wireless service facilities shall be as follows:

1. Place antennae and towers on public property, if practical.
2. Place antennae on appropriate rights-of-way.
3. Place antennae and towers in employment zoned districts.
4. Place antennae and towers in districts (in descending order of preference, ~~on existing broadcast and relay towers and wireless support structures, within employment districts, publicly owned structures, commercial structures or sites,~~ commercial districts, public institutional districts, and downtown business districts, which do not adjoin or adversely impact residential or waterfront districts.
5. Place antennae and towers on other non-residential property.
6. Place antennae and towers in the City multi-family zoned areas.
7. Place antennae and towers in multi-family residential structures exceeding thirty feet (30') in height.
8. Place antennae and towers in residential and waterfront zones-districts only if (a) locations are not available on existing structures or in non-residential districts; and (b) only on or in existing churches, parks, schools, utility facilities or other appropriate public facilities.

B. Co-location, General Requirements

C. General Requirements for Co-location. For new antenna and wireless communications facilities, co-location on existing towers and wireless support structures is preferred. Where co-location has been demonstrated to be impracticable, new towers are most appropriately located ~~in employment districts, followed by, in descending order of preference, commercial districts, public institutional districts, Downtown Business district, residential districts and waterfront districts as stated in~~

the order of preference in (B), above.

Co-location on existing wireless support structure broadcast and relay towers is encouraged by fewer standards and a simplified permit procedure. Attachment of antennae to existing nonresidential structures and buildings primarily within business park, employment and commercial districts is preferable to installation of new wireless support structures, broadcast and relay towers or monopoles. The City may request that the applicant perform feasibility studies associated with applications for communications facilities in order to demonstrate that locations on existing structures have been explored as the preferred siting alternative, or that ~~any particular height~~ height exceeding the development standards in this chapter requested by the applicant is necessary in order to provide ~~telecommunication~~ wireless communications, television, radio or other broadcast services.

The following must be demonstrated:

- a. Applicants are required to demonstrate: (i) that they have contacted the owners of structures in excess of thirty feet (30') within a one-quarter (1/4) mile radius of the proposed site and from which a location standpoint could provide part of a network for transmission of signals; (ii) have asked for permission to install the antenna on those structures; and (iii) were denied for reasons other than economic feasibility.
- b. The information submitted by the applicant shall include (i) a map of the area to be served by the tower or antenna, (ii) its relationship to other cell sites in the applicant's network, and (iii) an evaluation of existing buildings taller than thirty feet (30'), within one-quarter (1/4) mile of the proposed tower or antenna which from a location standpoint could provide part of a network to provide transmission of signals.

In addition to the above, an applicant desiring to locate a new antenna support structure in a residential or waterfront district shall demonstrate that a diligent effort has been made to locate the proposed communications facilities on a government facility, a private institutional structure, or other appropriate existing structures within a non-residential zone, and that due to valid considerations including physical constraints, and economic or technological feasibility, no appropriate location is available.

## **€ D. Permit Processing Requirements**

### **1. Permit Type**

- a. Small satellite dish antenna. Small satellite dish antenna shall comply with all Uniform Building Code requirements, and chapter 15.06 GHMC, but are otherwise exempt from the permit application procedures of Title 19 GHMC.**
- b. Large satellite dish antenna. Large satellite dish antennae and other antenna applications shall be processed as a Type II permit. A building permit shall also be required.**
- c. Amateur radio towers. Amateur radio towers applications shall be processed as a Type II permit. A building permit shall also be required.**
- d. Wireless communication facilities. A conditional use permit shall be required for wireless communication facilities in Residential, Waterfront District and Downtown Business Districts, which shall be processed as a Type III permit. For all other districts, wireless communication facilities shall be processed as a Type II permit. A building permit shall also be required.**
- e. Broadcast and relay towers. Broadcast and relay tower applications shall be processed as a Type II permit. A building permit shall also be required.**

### **2. Elements of a complete application. A complete application for the Type II permits described in this chapter shall consist an original of the following:**

- a. A site plan, drawn at a scale not less than 1 inch per 50 feet, showing the boundaries and dimensions of the parcel or site, including any adjacent public streets or easements.**
- b. An elevation of the proposed facility, including any buildings, existing or proposed, associated with the facility, and which shall include all dimensions of proposed structures.**

- c. A topographic map, based upon the most recent site survey or information available, at no less than five-foot contour intervals.
  - d. The required application fee as established pursuant to Chapter 3.40 GHMC.
  - e. Three copies of the original of the application.
  - f. A signed statement indicating that (1) the applicant and landowner agree that they will diligently negotiate in good faith to facilitate co-location of additional personal wireless service facilities by other providers on the applicant's structure or within the same site location and (2) the applicant and/or landlord agree to remove the facility within sixty (60) days after abandonment.
  - g. Copies of any environmental documents required by any federal agency. These shall include the environmental assessment required by FCC Para. 1.1307, or in the event that a FCC environmental assessment is not required, a statement that describes the specific factors that obviate the requirement for an environmental assessment.
  - h. A current map and aerial photograph showing the location of the proposed tower, a map showing the locations and service areas of other wireless service facilities operated by the applicant and those proposed by the applicant that are close enough to impact service within the City.
  - i. A statement by the applicant as to whether construction of the tower will accommodate co-location of additional facilities or antennas for future users.
3. A complete application for a conditional use permit shall, in addition to the elements described in 2(a), above, ~~shall~~ include those elements as described in Section GHMC § 17.96.050(B-D) and (L).

**17.61.030 Development Standards for all Public Institutional, Residential, Waterfront District and Downtown Business Districts (PI, R-1 R-2, R-3, RB-1, RB-2, PCD-RLD, PCD-RMD, WR, WM, WC, and DB).**

- A. Small Satellite Dish Antenna - Development Standards. Small satellite dish antenna shall not extend above the highest point of the roof.
- B. Large Satellite Dish Antenna - Development Standards. The following minimum standards apply to all Antennae:
  - 1. Siting on Lot. Large satellite dish antennae shall be ~~to-sited~~ in the rear yard as a first order of preference. If the applicant demonstrates that reception is not available in this location, the second order of preference for siting shall be the side yard. If the applicant demonstrates that reception is not available in this location, the third order of preference shall be the front yard. Finally, if reception is not available in any other location, the satellite dish antenna may be located on or attached to a roof, pursuant to the Special Exception procedures in GHMC 17.61.060.
  - 2. Height and Size. Antenna, antenna mountings and large satellite dishes shall be no taller than the minimum required for the purposes of obtaining an obstruction-free reception window. Large satellite dish antenna shall not exceed twelve feet (12') in diameter and fifteen feet (15') in height, including their bases. Height shall be measured from existing grade.
  - 3. Color. To the extent technically feasible, specific paint colors may be required to allow the antenna or large satellite dish and mounting structures to blend better with the surroundings.
  - 4. Screening, Landscaping. Screening of all large satellite dish antenna may be required with one or a combination of the following methods: fencing, walls, landscaping, structures or topography which will block the view of the antenna as much as practicable from any street and from the yards and main floor living areas of residential properties within approximately five hundred feet (500'). Screening may be located anywhere between the antenna and the above mentioned viewpoints. A dense vegetative screen (pursuant to GHMC § 17.04.269) shall be provided for large satellite dish antenna that are visible from any portion of the right-of-way. Landscaping installed for the



purposes of screening shall be maintained in healthy condition.

5. **Signs Prohibited.** Satellite dish antenna shall not be used for the purposes of signage or message display of any kind.
6. **UBC Conformance.** Construction plans and final construction of the mounting bases of all large satellite dish antenna shall be in accordance with the requirements established in the latest edition of the Uniform Building Code adopted by the City.
7. **Type of Dish.** Aluminum mesh dishes should be used, as practicable, instead of a solid fiberglass type large satellite dish antenna.
8. **Number of Dishes allowed.** Only one large dish satellite antenna shall be allowed on each residentially-zoned property.

C. **Amateur Radio Towers - Development Standards.** The following minimum standards apply to amateur radio towers:

1. **Siting on Lot.** Amateur radio towers may be ground or roof-mounted; however, ground-mounted towers must be located at a point farthest from lot lines as feasible, or the point farthest from residential structures on abutting properties.
2. **Height and Size.** The height of a ground-mounted tower may not exceed sixty-five feet (65') unless a ~~proposal~~ an applicant demonstrates that physical obstructions impair ~~the adequate use of the tower~~ reception. Telescoping towers may exceed the sixty-five foot (65') height limit only when extended and operating. The combined structure of a roof-mounted tower and antenna shall not exceed a height of twenty-five feet (25') above the existing roofline.
3. **Color.** To the extent technically feasible and in compliance with safety regulations, specific paint colors may be required to allow the tower to blend better with its setting.
4. **Screening, Landscaping.** Screening of the bases of ground-

mounted amateur radio towers shall be provided with one or a combination of the following methods: fencing, walls, landscaping, structures, and/or topography which will block the view of the antenna as much as practicable from any street and from the yards and main floor living areas of residential properties within approximately five hundred feet (500') of the tower. Screening may be located anywhere between the base and the above mentioned viewpoints. Landscaping for the purposes of screening shall be maintained in a healthy condition. Bases of amateur radio towers shall be solidly screened by a view-obscuring fence, wall, or evergreen plantings at least six feet (6') in height.

5. Signs Prohibited. No signs shall be placed or posted on amateur radio towers.
6. UBC Conformance. Construction plans and final construction of the mounting bases and towers of amateur radio towers covered by this Section shall meet the structural design requirements of this Section and shall be in accordance with the requirements established in the ~~latest edition of the~~ Uniform Building Code as adopted by the City.

D. Wireless Communication Facilities - Development Standards. The following standards shall be applied to all wireless ~~equipment~~ communication facilities, such as antenna and equipment shelters, exclusive of the broadcast and relay tower. Wireless monopoles, lattice, and guy towers are regulated by the sub-sections that govern broadcast and relay towers, ~~Section GHMC §~~ GHMC § 17.61.050(E)(2-7).

1. Siting on Lot. No wireless ~~equipment reviewed under this Section~~ communications facilities shall be located within required building setback areas.
2. Height and Size. The combined antenna and supporting structure shall not extend more than fifteen feet (15') above the existing or proposed roof structure.
3. Color, Screening, Landscaping.

- a. Wireless communication antenna installed on existing buildings shall be screened or camouflaged to the greatest practicable extent by use of shelters, compatible materials, location, color, and/or other stealth tactics to reduce visibility of the antenna as viewed from any street or residential property. The antenna shall be visually concealed utilizing color and compatible material to camouflage the facility to the greatest extent feasible.
  - b. Screening of wireless ~~equipment~~ communications facilities shall be provided with one or a combination of the following materials: fencing, walls, landscaping, structures, or topography which will block the view of the antenna and equipment shelter as much as practicable from any street and from the yards and main floor living areas of residential properties within 500 five hundred feet (500'). Screening may be located anywhere between the base and the above mentioned viewpoints.
  - c. Landscaping for the purposes of screening the wireless communications facilities shall be maintained in a healthy condition.
  - d. Any fencing required for security shall meet the screening standards of the City's Design Guidelines.
4. Signs Prohibited. No wireless equipment shall be used for the purposes of signage or message display of any kind.
  5. Conform to UBC. Wireless communication facilities shall comply with all applicable UBC requirements.
  6. Abandonment, Disrepair. A wireless communication facility shall be removed by the facility owner within 12 months of the date it ceases to be operational or if the facility falls into disrepair and is not maintained. Disrepair includes structural features, paint, landscaping, or general lack of maintenance which could result in safety or visual impacts.

7. Co-Location. Placement of a freestanding wireless communication facility may be denied if placement of the antenna on an existing structure can accommodate the operator's applicant/operator's communications needs. The applicant shall also comply with the co-location requirements of GHMC § 17.61.020(C). The co-location of a proposed antenna on an existing broadcast and relay tower or placement on an existing structure shall be explored and documented by the operator applicant/operator in order to show that reasonable efforts were made to identify alternate locations.
  
8. Equipment Shelters.
  - a. Limit on area. Associated above ground equipment shelters shall be minimized, and shall not exceed 240 two hundred forty (240) square feet (e.g. 12' x 20') unless operators can demonstrate that more space is needed.
  - b. Color. Shelters shall be painted a color that matches existing structures or the surrounding landscape.
  - c. Materials. The use of concrete or concrete aggregate shelters is not allowed.
  - d. Screening, Landscaping. A dense vegetative screen shall be created around the perimeter of the shelter.
  - e. Undergrounding. Operators shall consider undergrounding equipment if technically feasible or placing equipment within existing structures.
  - f. UBC Conformance. Equipment shelters shall comply with all UBC requirements, but may be exempt from building envelope insulation requirements (See, RCW 19.27A.027.)
  
- E. Broadcast and Relay Towers - Development Standards. Broadcast and Relay Towers are not permitted in any Residential, Waterfront District and Downtown Business districts.

**17.61.040 Siting Development Standards for all Commercial Districts (C-1, B-2, 1, B-1, 2, PCD-C, PCD-BP)**

- A. Small Satellite Dish Antenna. No additional development standards.
- B. Large Satellite Dish Antenna - Development Standards. In addition to the standards in GHMC § 17.61.030 (1-7), the following standards shall apply:
  - 1. Ground mounted antenna are subject to the following requirements:
    - a. Size. Such antenna shall not exceed twelve ~~(12)~~ feet (12') in diameter and fifteen ~~(15)~~ feet (15') in height. Height shall be measured from existing grade.
    - b. Placement. Ground-mounted antenna shall be located outside of any required landscape area and preferably located in service areas or other less visible locations.
    - c. Screening. From the time of installation, ground-mounted antenna shall be screened as high as the center of the dish when viewed from any public right-of-way. Solid screening shall be provided as high as the dish if the proposed location abuts an adjoining residential zone.
  - 2. Roof mounted antenna shall be solidly screened at least as high as the center of the dish. The screening shall be of a material and design compatible with the building, consistent with the City's Design Review Manual, and can include parapet walls or other similar screening.
- C. Amateur Radio Towers - Development Standards. In addition to the development standards in GHMC § 17.61.030(C), the following minimum standards apply:
  - 1. Placement. Amateur radio towers reviewed under this Section shall not be located within any easement, the front yard, side or rear yard building setback areas. Amateur

radio towers may be ground or roof mounted; however, ground mounted towers must be located at a point farthest from lot lines as feasible, or the point farthest from residential structures on abutting properties

2. Paint Colors. To the extent technically feasible and in compliance with safety regulations, specific paint colors may be required to allow the tower to blend better with its setting.
3. Screening. Screening of the bases of ground-mounted amateur radio towers shall be provided with one or a combination of the following methods: fencing, walls, landscaping, structures, or topography which will block the view of the antenna as much as practicable from any street and from the yards and main floor living areas of residential properties within approximately 500 five hundred feet (500'). screening may be located anywhere between the base and the above mentioned viewpoints. Landscaping for the purposes of screening shall be maintained in a healthy condition. Bases of amateur radio towers shall be solidly screened by a view-obscuring fence, wall, or evergreen plantings at least six feet (6') in height.
4. Signs. Amateur radio towers shall not be used for the purposes of signage and shall not display a sign of any kind.
5. UBC Conformance. Construction plans and final construction of the mounting bases and towers of amateur radio towers covered by this Section shall meet the structural design requirements of this Section and shall be subject to approval by the City Building Official.
7. Commercial Use prohibited. Towers Amateur radio towers located in residential districts shall not be constructed or used for commercial use purposes.
8. Height. The height of a ground-mounted tower may not exceed 65 sixty-five feet (65') unless a proposal an applicant demonstrates that physical obstructions impair the adequate use of the tower. Telescoping towers may exceed the 65 sixty-five-foot (65') height limit only when extended

and operating. The combined structure of a roof-mounted tower and antenna shall not exceed a height of ~~25~~ twenty-five feet (25') above the existing roofline.

D. **Wireless Communication Facilities - Development Standards.** In addition to the requirements of GHMC § 17.61.030(C), the following standards shall be applied to all wireless equipment communications facilities, such as antenna and equipment shelters, exclusive of any broadcast and relay tower. Wireless monopoles, lattice, and guy towers are regulated by the sub-sections that govern broadcast and relay towers, GHMC § 17.61.050(E)~~(2-7)~~.

1. Co-location. Installation of a freestanding wireless communication facility ~~shall~~ may be denied if placement of the antenna on an existing structure can accommodate the operator's communications needs. The applicant shall be required to comply with the co-location requirements of GHMC § 17.61.020(e). The co-location of a proposed antenna on an existing broadcast and relay tower or placement on an existing structure shall be explored and documented by the operator in order to show that reasonable efforts were made to identify alternate locations.
2. Location. No wireless equipment communications facilities reviewed under this Section shall be located within required building setback ~~set back~~ areas.
3. Height. The combined antenna and supporting structure shall not extend more than ~~15~~ fifteen feet (15') above the existing or proposed roof structure.
4. Signs. No wireless equipment shall be used for the purposes of signage or message display of any kind.
5. Visibility. Location of wireless communication antenna on existing buildings shall be screened or camouflaged to the greatest practicable extent by use of shelters, compatible materials, location, color, and/or other stealth tactics to reduce visibility of the antenna as viewed from any street or residential property.
6. Screening. Screening of wireless equipment shall be provided with one or a combination of the following

materials: fencing, walls, landscaping, structures, or topography which will block the view of the antenna and equipment shelter as much as practicable from any street and from the yards and main floor living areas of residential properties within ~~500~~ five hundred feet (500'). Screening may be located anywhere between the base and the above mentioned viewpoints. Landscaping for the purposes of screening shall be maintained in a healthy condition.

7. Fencing. Any fencing required for security shall meet screening codes in the same manner as applied to screening for mechanical and service areas.
8. UBC Conformance. Construction plans and final construction of the mountings of wireless antenna and equipment shelters shall be approved by the City Building Official. Applications shall document that the proposed broadcast and relay tower and any mounting bases are designed to reasonably withstand wind and seismic loads.
9. Abandonment, Disrepair. A wireless communication facility shall be removed by the facility owner within ~~12~~ twelve (12) months of the date it ceases to be operational or if the facility falls into disrepair and is not maintained. Disrepair includes structural features, paint, landscaping, or general lack of maintenance which could result in safety or visual impacts.
10. Equipment Shelters. Associated above-ground equipment shelters shall not exceed ~~240~~ two hundred forty (240) square feet (e.g. 12' x 20') unless operators can demonstrate that more space is needed. A dense vegetative screen shall be created around the perimeter of the shelter. Operators shall consider under-grounding equipment is technically feasible or placing the equipment within an existing structure. Above ground equipment shelters for antenna located on buildings shall be located within, on the sides or behind the buildings and screened to the fullest extent possible.

E. Broadcast and Relay Towers - Development Standards. Broadcast and Relay Towers are prohibited in all Commercial Districts.



**17.61.050 Siting Standards for Employment District (ED).**

- A. Small Satellite Dish Antenna. No additional development standards.
- B. Large Satellite Dish Antenna and other Antenna. The development standards in GHMC § 17.61.030(B) shall apply.
- C. Amateur Radio Towers. The development standards in GHMC § 17.61.030(C) shall apply.
- D. Wireless Communication Facilities. The development standards of GHMC § 17.61.030(D) shall apply.
- E. Broadcast and Relay Towers. The following minimum standards apply to broadcast and relay towers:
  - 1. Location. Broadcast and relay towers are restricted to Employment Districts west of SR-16, north of a line extending east-west from 97th Street NW and south of the Swede Hill interchange
  - 2. Siting on Lot. Broadcast and relay towers reviewed under this Section shall not be located within any required building setback areas.
  - 3. Height and Size. The combined height of a broadcast and relay tower and antenna shall not exceed ~~85~~ eighty-five feet (~~85'~~) except when co-location is specifically provided for, then the broadcast and relay tower shall not exceed ~~100~~ one hundred feet (100').
  - 4. Color. To the extent technically feasible and in compliance with safety regulations, specific colors of paint may be required to allow the broadcast and relay tower to blend better with its setting.
  - 5. Landscaping, Screening. Any fencing required for security shall meet screening codes in the same manner as applied to screening for mechanical and service areas.
  - 6. Signs Prohibited. Broadcast and relay towers shall not be used for

the purposes of signage to display a message of any kind.

7. Co-Location. Placement of a broadcast and relay tower may be denied if an alternative placement of the antenna on a building or other existing structure can accommodate the communications needs. Applicants shall be required to provide documentation that reasonable efforts to identify alternative locations were made.
8. Future Co-Location Accommodation. Owners and operators of a proposed broadcast and relay tower shall provide information regarding the opportunity for the co-location of other antenna and related equipment. If feasible, provision for future co-location may be required.
9. Federal Requirements. All towers and antennas must meet or exceed current standards and regulations of the FAA, the FCC, and any other agency of the federal government with the authority to regulate towers and antennas. If those standards and regulations are changed, then wireless service providers governed by this chapter shall bring their towers and antennas into compliance with the revised standards and regulations within three (3) months of their effective date or the timelines provided by the revised standards and regulations, whichever is longer. The revised standards and regulations are not retroactively applicable to existing providers, unless otherwise provided by federal law. Failure to bring towers and antennas into compliance with the revised standards and regulations shall constitute grounds for the City to remove a provider's facilities at the provider's expense.
10. Building Codes, Safety Standards. To ensure the structural integrity of towers, antennas and facilities, the applicant/owner shall ensure that they are maintained in compliance with standards contained in the applicable City building codes and the applicable standards for towers published by the Electronic Industry Association (EIA), as amended from time to time. If, upon application for a building permit or inspection, the City concludes that a tower fails to comply with such codes and standards and constitutes a danger to persons or property, then upon notice being provided to the owner of the tower, the owner shall have thirty (30') days to bring the tower into compliance with such standards. If the owner fails to bring the tower into compliance within thirty (30') days, the City may remove the tower at the owner's expense.

11. Structural design. Towers shall be constructed to Electronic Industry Association Standards, which may be amended from time to time, and to all applicable codes adopted by the City. Further, any improvements or additions to existing towers shall require submission of site plans stamped by a professional engineer which demonstrate compliance with EIA Standards and all other applicable industry practices. The plans shall be submitted and reviewed at the time applications for building permits are submitted.
12. Abandonment, Disrepair. All broadcast and relay towers shall be removed by the facility owner within 12 months of the date it ceases to be operational, or if the facility falls into disrepair and is not maintained. Disrepair includes structural features, paint, landscaping, or general lack of maintenance which could result in safety or visual impacts.

#### 17.61.060 Special Exceptions.

- A. Purpose. An applicant may apply for a special exception ~~may be considered~~ where the strict application of the standards for the specific type of facility would result in the obstruction or inability to receive a communication signal.
- B. Complete Application. An application for a Special Exception is processed under the same permit type as the underlying permit. A complete application for a Special Exception shall consist of:
  1. ~~The applicant's justification for the request for Special Exception by demonstrating that the obstruction or inability to receive a communication signal is the result of factors beyond the property owner's or applicant's control. This shall take into consideration potential permitted development on adjacent and neighboring properties respective to future "reception window obstruction". Photographs, sealed drawings, maps and/or manufacturers specifications and other technical information as necessary should be provided to demonstrate to the City that the Special Exception is necessary. A completed application form as required by the City Planning and Building Services~~

Department

2. ~~The applicant for a Special Exception shall demonstrate that the proposed material, shape and color of the antenna will minimize negative visual impacts on adjacent or nearby residential uses to the greatest extent possible. The use of certain materials, shapes and colors may be required in order to minimize visual impacts. The required application fee.~~
  3. A written statement which satisfactorily demonstrates that all of the Special Exception criteria have been met
- C. General Criteria. Each determination granting a Special Exception shall be supported by written findings of fact and conclusions demonstrating that all of the following general criteria and all specific criteria in subsection (D) below have been met:
1. The applicant has demonstrated that strict application of this Code would result in an inability to receive a signal or to effectively provide tele-communications services, and that this is the result of factors beyond the control of the applicant; and,
  2. The proposed material, shape and color of the antenna will minimize visual impacts on neighboring properties to the greatest extent possible; and,
  3. Where appropriate, the applicant has demonstrated that the antenna will allow co-location for additional antennas and/or/telecommunication facilities.
- D. Special Exception Criteria for specific facilities. In addition to the applicant's submission of materials described in subsection B above, a special exception may only be granted in accordance with the following criteria:
1. Large Satellite Dish Antenna and other Antenna - Special Exceptions
    - a. Residential Zones

- (1) Modifications to requirements for setbacks, size, screening and maximum height may be considered by Special Exception.
- (2) If a Special Exception is requested from the height limit for a ground-mounted dish, the height of the dish shall be limited to a maximum of eighteen feet (18') above the existing grade.
- (3) A rooftop location shall only be considered if the requirements of this chapter would result in reception blockage. If a Special Exception is sought to obtain a rooftop location, the diameter of the dish shall be limited to ~~4-8 meters~~ six feet (6') and a maximum permitted height of fifteen feet (15') above the roofline. The approval authority may require the applicant to place the antenna in an area of the roof which takes into consideration view blockage and aesthetics, provided reception is available.

b. Commercial and Employment Districts

- (1) Ground-mounted antenna. Exceptions to be first considered shall be from setback, landscape and service area requirements, size and screening requirements. Only if these waived regulations would still result in reception blockage shall a Special Exception from height requirements be considered. If a Special Exception is sought to vary from the height limit, the height of the dish shall be limited to a maximum of twenty feet (20') above the existing grade.
- (2) Roof-mounted antenna. The first exception to be considered shall be the center of the roof requirement; the second exception shall be from the size and screening requirements, respectively. Only if these waived

regulations would still result in the blockage of an electromagnetic signal, shall a Special Exception from height requirements be considered. A Special Exception from the height limit shall be allowed up to a maximum of twenty feet (20') above the existing or proposed structure. The approval authority may require the applicant to place the antenna in an area on the roof which takes into consideration view blockage and aesthetics, provided there is a useable signal and structural considerations allow the alternative placement.

2. Amateur Radio Towers - Special Exceptions. Residential Zones -- Where a property owner desires to vary from the height, location or setback limitations, the Special Exception Criteria must be met.
3. Wireless Communications Facilities - Special Exceptions
  - a. Residential Zones - An applicant for a proposed wireless facility that exceeds the height limit shall meet the Special Exception Criteria.
  - b. Commercial and Industrial Zones - An applicant for a proposed wireless facility that exceeds the height limit shall meet the Special Exception Criteria.
4. Broadcast and Relay Towers - Special Exceptions
  - a. Commercial and Employment Districts - An applicant for a proposed broadcast and relay tower that exceeds height limits shall be required to obtain a conditional use permit under GHMC § 17.64.046.

#### **17.61.070 Review by Independent Consultant – Third Party Review**

- A. Wireless service providers use various methodologies and analyses, including geographically based computer software, to determine the specific technical parameters of their services and low power mobile radio service facilities, such as expected coverage area, antenna configuration,

topographic constraints that affect signal paths, etc. In certain instances, a third party expert may need to review the technical data submitted by a provider. The City may require a technical review as part of the permitting process. The costs of the technical ~~The Planning Director may, at his or her discretion, require that technical information provided by the applicant in justification for a wireless or telecommunication facility, or a broadcast and relay tower at a proposed location be reviewed by a qualified individual or firm selected by the City. The costs for such review shall be borne solely by the applicant.~~ by the provider.

Section 10 The selection of the third party expert may be by mutual agreement between the provider and the City, or, at the discretion of the City, with a provision for the provider and interested parties to comment on the proposed expert and review his/her qualifications. The expert review is intended to address interference and public safety issues and be a site-specific review of technical aspects of the facilities or a review of the provider's methodology and equipment used. The expert review is not intended to be a subjective review of the site which was selected by the provider. Based on the results of the expert review, the City may require changes to the provider's application. The expert review shall address the following:

1. the accuracy and completeness of submissions;
2. the applicability of analysis techniques and methodologies;
3. the validity of the conclusions reached; and
4. any specific technical issues designated by the City.

Section 13. Section 17.45.030 of the Gig Harbor Municipal Code is amended to read as follows:

**17.45.030 Conditional uses**

Subject to the requirements, standards and procedures for conditional uses set forth in Chapter 17.64 GHMC, the following uses may be permitted in an education district:

- A. Hospitals, clinics and establishments for people convalescing from illness or operation;

- B. Senior citizen housing;
- C. Commercial child care facilities;
- D. Public utilities and public services such as libraries, electrical substations, telephone exchanges, ~~telecommunication facilities~~, police and fire stations;
- E. Recreational buildings and outdoor recreation;
- F. Houses of religious worship;
- G. Planned unit developments with a minimum of 65 percent of the site consisting of an employment based use; and
- H. Ministorage facilities.

Section 11.14. Chapter 17.64.040 of the Gig Harbor Municipal Code is amended to read as follows:

**17.64.040 Review criteria**

Each determination granting or denying a conditional use permit shall be supported by written findings of fact showing specifically wherein all of the following conditions are met:

- A. That the use for which the conditional use permit is applied for is specified by this title as being conditionally permitted within, and is consistent with the description and purpose of the zone district in which the property is located;
- B. That the granting of such conditional use permit will not be detrimental to the public health, safety, comfort, convenience and general welfare, will not adversely affect the established character of the surrounding neighborhood, and will not be injurious to the property or improvements in such vicinity and/or zone in which the property is located;
- C. That the proposed use is properly located in relation to the other land uses and to transportation and service facilities in the vicinity; and further, that the use can be adequately served by such public facilities and street capacities without placing an undue burden on such facilities and streets;
- D. That the site is of sufficient size to accommodate the proposed use and all



yards, open spaces, walls and fences, parking, loading, landscaping and other such features as are required by this title or as needed in the opinion of the examiner.

For wireless communication facilities ~~and broadcast and relay towers~~, the criteria in Section 17.64.046 shall apply.

Section 12 15. A new section 17.64.046 of the Gig Harbor Municipal code is adopted as follows:

**17.64.046 Conditional Use Permits for Review Criteria for Wireless Communication Facilities, Broadcast and Relay Towers.**

- A. Type of Permit. Applications for conditional use permits for wireless communications and broadcast and relay towers shall be processed as a Type III permit.
- B. Criteria for Approval. Applications for conditional use permits for wireless communication facilities ~~and broadcast and relay towers~~ may be approved if the applicant demonstrates all of the following:
  - 1. That there will be no injury to the neighborhood or other detriment to the public welfare;
  - 2. That there is a need for the proposed tower to be located in or adjacent to the residential area, and which shall include documentation on the procedures involved in the site selection and an evaluation of alternative sites and existing facilities on which the proposed facility could be located or co-located;
  - 3. The feasibility of future consolidated use of the proposed facility or co-location with other public utility facilities;
  - 4. The facility shall be designed to be as least intrusive as practicable, including, but not limited to, the exterior treatment of the facility so as to be harmonious with the character of the surrounding neighborhood, the use of landscaping and privacy screening to buffer the facility and activities on the site from surrounding properties and that any equipment that is not enclosed shall be designed and located on the site to minimize impacts related to noise, light and glare onto surrounding properties.

**Section 16. Severability.** If any section, sentence, clause or phrase of this ordinance should be held to be invalid or unconstitutional by a court of competent jurisdiction, such invalidity or unconstitutionality shall not affect the validity or constitutionality of any other section, sentence, clause or phrase of this ordinance.

**Section 14. 17. Effective Date.** This ordinance shall be in effect five (5) days after publication of an approved summary.

PASSED BY THE CITY COUNCIL FOR THE CITY OF GIG HARBOR AT IS  
REGULAR MEETING dated the \_\_\_\_ day of \_\_\_\_\_, 1997.

APPROVED:

By: \_\_\_\_\_

Gretchen Wilbert, Mayor

ATTEST/AUTHENTICATED:

By: \_\_\_\_\_

Molly Towslee, City Clerk

APPROVED AS TO FORM:  
OFFICE OF THE CITY ATTORNEY

By: \_\_\_\_\_  
CITY ATTORNEY

FILED WITH THE CITY CLERK:  
PASSED BY THE CITY COUNCIL:  
PUBLISHED:  
EFFECTIVE DATE:  
ORDINANCE NO.

SUMMARY OF ORDINANCE NO. \_\_\_

of the City of Gig Harbor, Washington

---

On the \_\_\_\_\_ day of \_\_\_\_\_, 1997, the City Council of the City of Gig Harbor, passed Ordinance No. \_\_\_\_\_. A summary of the content of said ordinance, consisting of the title, provides as follows:

AN ORDINANCE OF THE CITY OF GIG HARBOR CITY COUNCIL RELATING TO LAND USE AND ZONING, ~~ADOPTING DEFINITIONS FOR COMMUNICATION FACILITIES SUCH AS AMATEUR RADIO ANTENNA, SATELLITE DISH ANTENNA~~ ESTABLISHING SITING STANDARDS FOR AMATEUR RADIO ANTENNAE, SATELLITE DISH ANTENNAE, TELEVISION AND RADIO BROADCAST TOWERS, AND TELECOMMUNICATION FACILITIES REGULATED UNDER THE FEDERAL TELE-COMMUNICATIONS ACT OF 1996, ADOPTING DEVELOPMENT STANDARDS, AND PROVIDING FOR SPECIAL EXCEPTIONS AND CONDITIONAL USE PERMITS; ADDING A NEW CHAPTER 17.61; ADDING NEW SECTIONS 17.04.041, 17.04.125, 17.04.225, 17.04.756, 17.04.757, 17.04.758 AND 17.64.046; AMENDING SECTIONS 17.04.055, 17.04.710, 17.45.030 AND 17.64.040 OF THE GIG HARBOR MUNICIPAL CODE.

The full text of this Ordinance will be mailed upon request.

DATED this \_\_\_\_\_ day of \_\_\_\_\_, 1997.

---

MOLLY TOWSLEE, CITY CLERK





*City of Gig Harbor. The "Maritime City."*

3105 JUDSON STREET  
GIG HARBOR, WASHINGTON 98335  
(253) 851-8136

**TO: MAYOR WILBERT AND CITY COUNCIL**  
**FROM: MARK HOPPEN, CITY ADMINISTRATOR** *MH*  
**SUBJECT: SECOND READING OF ORDINANCE - COLLECTION OF DEBT**  
**DATE: OCTOBER 1, 1997**

**INFORMATION/BACKGROUND**

This is the second reading of an ordinance that authorizes the costs of a collection agency involved in the collection of municipal debt to be added to the costs to be paid by the debtor. This capacity increases the proportion of collectible debt that can be realized.

**RECOMMENDATION**

Staff recommends the approval of this ordinance.

ORDINANCE NO. \_\_\_\_\_

**AN ORDINANCE OF THE CITY OF GIG HARBOR, WASHINGTON, REGARDING COLLECTION OF DEBTS OWED TO THE CITY, PROVIDING THAT THE COSTS OF COLLECTION, INCLUDING COLLECTION AGENCY COSTS, SHALL BE ADDED TO THE AMOUNT OF ANY DEBTS OWED TO THE CITY, AND ADDING A NEW SECTION 3.48.030 TO THE GIG HARBOR MUNICIPAL CODE.**

---

WHEREAS, RCW 19.16.500 has authorized cities to assign the collection of any debts owed to the city to a collection agency; and

WHEREAS, a new subsection was added to RCW 19.15.500 by the 1997 Washington State Legislature permitting the costs involved in the collection of debts through the use of a collection agency to be added to and included in the debt to be paid by the debtor; and

WHEREAS, it is prudent and appropriate that the City Council authorize that the costs of collection of debts through collection agencies be added to the debt assigned to a collection agency by the City; NOW THEREFORE,

BE IT ORDAINED by the City Council of the City of Gig Harbor, Washington as follows:

Section 1. A new section 3.48.030 is hereby added to the Gig Harbor Municipal Code to read as follows:

3.48.030 Collection Costs Recoverable. In all instances where the City assigns to a collection agency for a collection of any debt owed to the city, including but not limited to past due utility charges, fines, assessments, and permit and license fees and charges, the costs involved in the collection of the debt through use of the collection agency are costs that shall be added to and included in the debt to be paid by the debtor.

Section 2. - Effective Date. This ordinance, being an exercise of a power specifically delegated to the City legislative body, is not subject to referendum. This ordinance shall take effect five (5) days after passage of publication of an approved summary thereof consisting of the title.

PASSED AND ADOPTED by the Gig Harbor City Council this \_\_\_\_ day of \_\_\_\_\_, 1997.

APPROVED:

---

MAYOR, GRETCHEN A. WILBERT

ATTEST/AUTHENTICATED:

---

CITY CLERK, MOLLY M. TOWSLEE

APPROVED AS TO FORM:  
OFFICE OF THE CITY ATTORNEY:

---

FILED WITH THE CITY CLERK:  
PASSED BY THE CITY COUNCIL:  
PUBLISHED:  
EFFECTIVE DATE:  
ORDINANCE NO.

**SUMMARY OF ORDINANCE NO.**

of the City of Gig Harbor, Washington

On the \_\_\_\_ day of \_\_\_\_\_, 199\_\_, the City Council of the City of Gig Harbor, passed Ordinance No. \_\_\_\_\_. A summary of the content of said ordinance, consisting of the title, provides as follows:

**AN ORDINANCE OF THE CITY OF GIG HARBOR, WASHINGTON, REGARDING COLLECTION OF DEBTS OWED TO THE CITY, PROVIDING THAT THE COSTS OF COLLECTION, INCLUDING COLLECTION AGENCY COSTS, SHALL BE ADDED TO THE AMOUNT OF ANY DEBTS OWED TO THE CITY, AND ADDING A NEW SECTION 3.48.030 TO THE GIG HARBOR MUNICIPAL CODE.**

The full text of this Ordinance will be mailed upon request.

DATED this \_\_\_\_ day of \_\_\_\_\_, 199\_.

---

CITY CLERK, MOLLY M. TOWSLEE





City of Gig Harbor. The "Maritime City."

3105 JUDSON STREET  
GIG HARBOR, WASHINGTON 98335  
(253) 851-8136

**TO: MAYOR WILBERT AND CITY COUNCIL**  
**FROM: MARK HOPPEN, CITY ADMINISTRATOR**  
**SUBJECT: PIONEER PARK - ROTARY PROJECT**  
**DATE: OCTOBER 5, 1997**

### INFORMATION/BACKGROUND

For years, the Rotary Club has wished to display the last remaining light pole from the original Narrows Bridge in some suitable location as an historic reference to those who worked on the original bridge, known as Galloping Gertie. KeyBank has graciously offered to provide a space just downhill from Uddenberg Street on Pioneer Way as a site for a pocket park to offer pedestrians a respite and a look at an unusual piece of local history. The light pole would stand approximately 24' high and would be functional, so lighting concerns would be evident. Low maintenance landscaping and installation would be provided by the Rotary Club of Gig Harbor. Peninsula Light Company has offered to assist Rotary in preparation of the light pole in this endeavor.

*In August, Council requested that the project be revised with the orientation of seating directed downhill and with the revised project reviewed through the design review process. The orientation of the seating proved to be problematic. In order to re-design the project for seating, the area necessary for the project needed expansion. The bank was unwilling to make this further commitment. Thus, the project as presented previously is back before Council unaltered. The project as previously presented can be built within design standard parameters according to planning staff.*

### POLICY CONSIDERATIONS

KeyBank Corporation is willing to lease the area to the City of Gig Harbor for public park purposes on the conditions expressed in the attached lease agreement. KeyBank expresses numerous conditions in the lease agreement which retain KeyBank's ability to use the property for development without expense to KeyBank. The principal such requirement is that if the city turns the property back to KeyBank, at the initiative of either KeyBank or the city, then the city is responsible to restore the property to its original condition.

The chief reason for the city's involvement with this lease is liability coverage provided by virtue of the city's immunity from liability for sites utilized for municipal park purposes.

This proposal is consistent with the City of Gig Harbor Parks, Recreation and Open Space Plan following "Goals and Objectives":

#### **Historical Resources**

Develop a high quality, diversified park system that preserves significant historical

opportunity areas and features.

**5: Historical features and interests**

b: Identify and incorporate significant historical and cultural lands, sites, *artifacts*, and facilities into a park system to preserve these interests and provide a balanced social experience - such as St. Nicholas' Catholic Church or the present Peninsula Historical Society Museum.

**FISCAL CONSIDERATIONS**

The city would be responsible for the maintenance of site.

**RECOMMENDATION**

Staff indicates that it is possible to use the site as proposed. Staff recommends approval of the attached lease agreement.

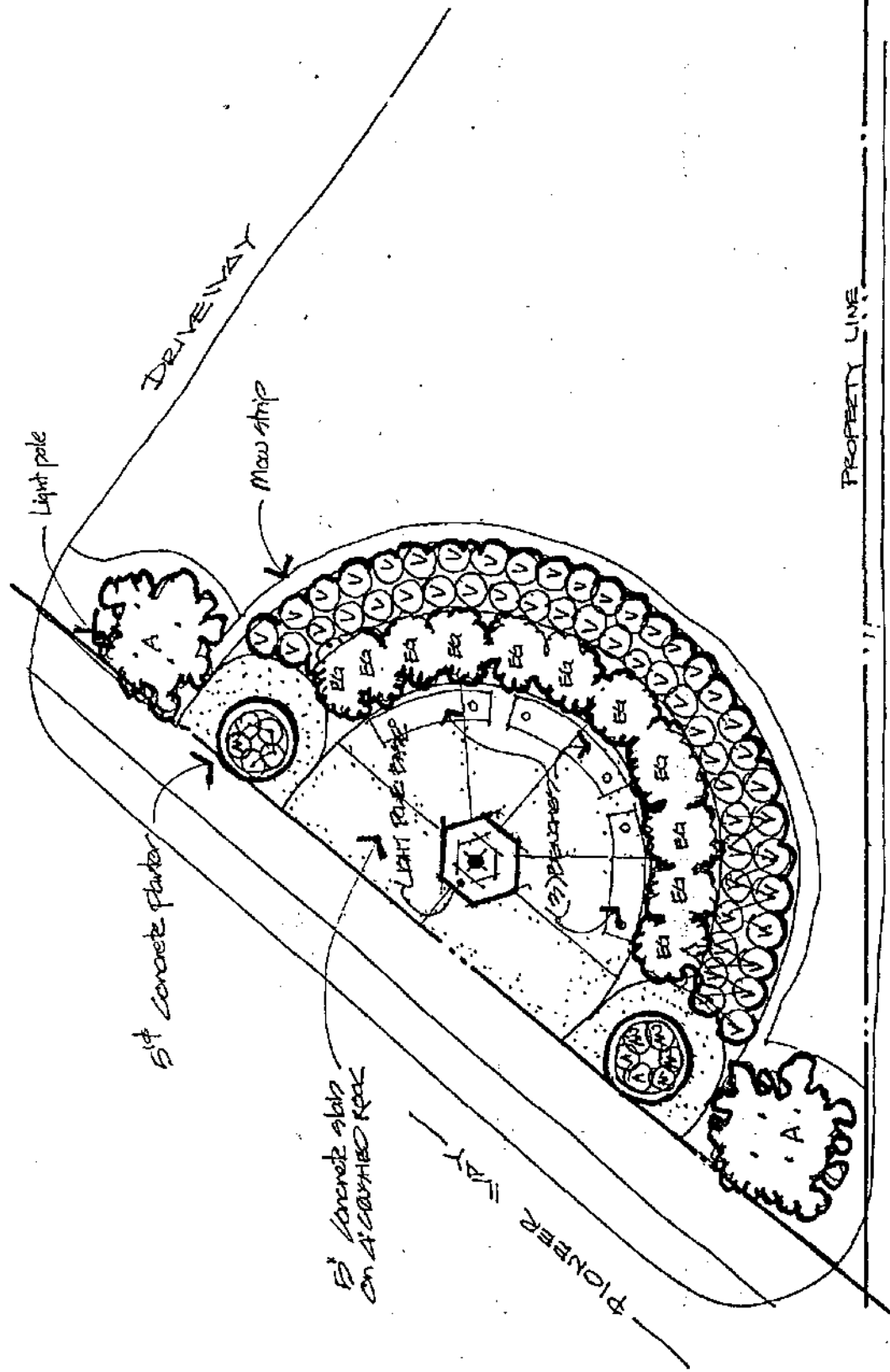

PLANTING PLAN PIONEER PARK

SCALE 1" = 10'-0"

5-4-97

## LEASE AGREEMENT

THIS LEASE, is made this 6th day of August, 1997, by and between the City of Gig Harbor, a Washington municipal corporation, hereinafter referred to as Lessee, and KeyBank National Association, formerly KeyBank of Washington, a corporation organized under the laws of the State of Washington, hereinafter referred to as Lessor.

### WITNESSETH:

1. Premises. The Lessor does hereby lease to the Lessee, and the Lessee does hereby lease from the Lessor, certain real property located at Pioneer Street and Uddenburg Lane , Gig Harbor, situate in the County of Pierce, State of Washington and legally described as follows:

*See Attached Exhibit 'A'.*

hereinafter referred to as the Premises. Lessee shall have no care, custody, control or right to use any portion of the real property other than that described below:

2. Use. The Lessee shall maintain the Premises for public park purposes only, and shall not use the Premises for any additional or illegal purposes.

3. Equipment. The Lessee shall, at Lessee's full expense, develop the Premises as illustrated in Exhibit 'B', or as may later be approved in writing by Lessor. No other erections nor improvements may be made to the Premises without the prior written consent of the Lessor, whose consent may be withheld at the Lessor's sole discretion.

4. Installation, Use, Operation and Removal. Lessee specifically agrees that in the installation, use, operation or removal of the park improvements described in paragraph 3, Lessee shall do nothing that shall in any way damage or otherwise affect real property owned by Lessor.

5. Alterations. Except as provided in paragraph 3 hereof, the Lessee shall not make any alterations, additions or improvements in the Premises, without the prior review and written consent of the Lessor. Said consent may be withheld at the sole discretion of the Lessor. In addition, all alterations, additions and improvements made by the Lessee shall be at the sole cost and expense of the Lessee, and removed by the Lessee at the termination of this lease. If the Lessee shall perform work with the consent of the Lessor, as aforesaid, the Lessee agrees to comply with all laws, ordinances, rules and regulations of the public authorities with jurisdiction, to save and hold the Lessor harmless from damage, loss or expense arising out of the said work and to remove all liens or encumbrances arising as a result of said work.

6. Care of Premises. The Lessor shall not be called upon to make any improvements or repairs of any kind upon that portion of the Premises occupied by the Lessee. The Lessee covenants and agrees that it shall occupy and use the Premises at all times in accordance with the laws and ordinances of the State of Washington and the City of Gig Harbor, and in accordance with all directions, rules, and regulations of the health officer, fire marshal, building inspector, or other proper officer of any public authority with jurisdiction, at the sole expense of the Lessee. The Lessee shall not permit waste, damage or injury to the Premises.

7. Access. The Lessee will allow the Lessor, its officials, employees and agents free access at all times to the Premises. This right of access shall not be construed as an agreement on the part of the Lessor to make any repairs on that portion of the Premises occupied by the Lessee, which repairs shall be wholly the Lessee's obligation.

8. Interference. Lessor agrees not to enter into leases for the premises with any other tenants that would be inconsistent with public park purposes. Lessor shall condition all future leases by prohibiting any new tenant from causing interference with the Lessee's use of the Premises.

9. Rent. The Lessee covenants and agrees to pay Lessor during the term, at the address in Section 1 herein, or as otherwise specified in writing, rent in the amount of one and no/100 Dollars (\$1.00) per month, to be paid yearly for the first year of said lease for the premises illustrated in Exhibit 'C'. This amount shall be payable in advance, on the first day of the year.

10. Consideration. As partial consideration for the execution of this lease, the Lessee has this date paid the Lessor the sum of twelve and no/100 Dollars (\$12.00), receipt of which is hereby acknowledged. If the Lessee shall have fully complied with all the covenants, agreements, terms and conditions of this lease, but not otherwise, this sum shall be credited on the payment of the last annual rental payment of the term of this lease.

11. Fees and Taxes. The Lessee shall pay promptly, and before they become delinquent, any applicable taxes on all personal property and improvements owned or placed by the Lessee on the Premises; shall pay all license fees and public utility charges related to the conduct of the Lessee's business on the Premises; shall pay for all permits, licenses and zoning approvals relating to the conduct of a public park on the Premises by the Lessee; and shall pay any lease tax arising as a result of the execution of this lease.

12. The Term. The term of this lease shall commence on the date of execution of this lease and shall end five years thereafter, unless sooner terminated as provided below.

13. Extensions. At the end of the initial five year Term, Lessor agrees to permit Lessee additional annual (12 month duration) extensions of this Agreement, IF (a) Lessee is not in violation

of any terms and conditions of this Agreement, and (b) Lessor is not then electing to exercise its options for early termination as permitted in Section 16 below.

14. Holdover. If the Lessee shall, with the written consent of the Lessor, holdover after the expiration of the term of this lease, the holdover tenancy shall be for an indefinite period of time on a month to month basis, which tenancy may be terminated by the provision of 30 days advance written notice by the party seeking termination of the tenancy to the other party. During such tenancy, the Lessee agrees to pay the Lessor the same rate of rental as was paid during the immediate past lease term unless a different rate is established by the Lessor, and further agrees to be bound by all of the terms, covenants, agreements and conditions as herein specified, so far as applicable.

15. Termination, Default and Reentry. Anytime during the term, including any extensions of this Agreement, Lessor and/or Lessee may terminate said Agreement by providing a minimum of 90-days written notice to the other party of its intent to so Terminate.

16. Non-Release of Obligations upon Termination. No termination, default or cancellation of this lease shall release Lessee from any liability or obligation with respect to any matter occurring prior to such termination, default or cancellation, nor shall termination, default or cancellation release Lessee from its obligation and liability as described in Section 3 herein to remove its facilities and equipment and restore the Premises.

17. Lessee's Removal of Its Property. Upon the surrender of the Premises by the Lessee, the Lessee shall remove, at Lessee's sole expense, from the Premises the personal property described in paragraph 3 above, and shall restore the Premises, at Lessee's sole expense, to its original condition, ordinary and reasonable wear and tear excepted.

18. Lessor's Removal of Lessee's Property. In the event of damage to, injury in, or any taking possession of, the Premises as aforementioned, the Lessor shall have the right, but not the obligation, to remove from the Premises all of Lessee's personal property located therein, and may store the same in any place selected by the Lessor, including, but not limited to, a public warehouse at the expense and risk of the Lessee thereof. If the Lessor removes the Lessee's property as provided under this section, it shall immediately provide Lessee written notice of such removal, and notice of the Lessee's right to redeem the property after payment of any sums due the Lessor, including the Lessor's costs of removal and storage. If Lessee does not redeem the property, the Lessor shall have the right to sell such stored property. If such property has thereafter been stored for a period of thirty (30) days or more and then sold, the proceeds of such sale shall be applied first to the cost of the sale, second to the payment of the charges for storage, if any, and third to the payment of any other sums of money which may then be due from the Lessee to the Lessor under any terms hereof, the balance, if any, to be paid to the Lessee.

19. Cancellation. In the event that the Lessee determines that the Premises are unsuitable for the intended purpose as described in this lease, Lessee reserves the right to cancel this lease upon one hundred twenty days (120) written notice to the Lessor and Lessee shall comply with Section 17.

20. Indemnification and Waiver. Lessee shall place, operate and maintain all of its personal property and structures on the Premises at its own risk.

The Lessee agrees to defend, indemnify, and hold the Lessor, its officers, officials, employees and volunteers harmless from any and all claims, injuries, damages, losses or suits, including attorneys' fees, arising out of or in connection with the performance of this lease, except to the extent



said claims, injuries, damages, losses or suits arise out of or are in connection with the acts or negligence (sole or concurrent negligence) of Lessor, its officers, employees or agents.

21. Insurance. The Lessee shall procure and maintain for the duration of the lease, insurance against claims for injuries to persons or damage to the Property which may arise from or in connection with the performance of the lease by the Lessee, its agents, representatives or employees. The Lessee shall provide a Certificate of Insurance evidencing commercial general and public liability insurance written on an occurrence basis with limits no less than \$1,500,000 combined single limit per occurrence and \$2,000,000 aggregate for personal injury, bodily injury and property damage.

22. Fire and Other Casualty. In the event the Premises are destroyed or damaged by fire, earthquake or other casualty to such an extent as to render the same untenable by the Lessee in whole or in a substantial part, Lessee shall have the option to terminate the lease immediately without further liability or obligation to Lessor.

23. Condemnation. In the event of the taking of the Premises by condemnation or otherwise by any governmental, state or local authority, this Lease shall be deemed canceled as of the time of taking possession by said authority and, if the Lessee is not in default under any provisions of this Lease on that date, the Lessee shall be entitled to a prorata refund of any rental prepaid for the period beyond the date of cancellation. The Lessee shall have no claim to nor shall it be entitled to any portion of any condemnation or other award for damages to the Premises.

24. Liens and Insolvency. The Lessee shall keep the Premises free from any liens arising out of any work performed, materials furnished or obligations incurred by the Lessee. In the event the Lessee becomes insolvent, voluntarily or involuntarily bankrupt, or if a receiver, assignee or

other liquidating officer is appointed for the business of the Lessee, then the Lessor may cancel this lease at the Lessor's option.

25. Entire Agreement. The written provisions of this Agreement shall supersede all prior verbal statements of any officer or other representative of Lessor, and such statements shall not be effective or be construed as entering into, forming a part of, or altering in any manner whatsoever, this lease. The entire agreement between the parties with respect to the subject matter is contained in this lease.

26. Modification, Waiver. No waiver, alteration or modification of any of the provisions of this Agreement shall be binding unless in writing and signed by a duly authorized representative of the parties.

27. Non-Waiver of Breach. The failure of the Lessor to insist upon strict performance of any of the covenants and agreements of this lease, or to exercise any option herein conferred in any one or more instances, shall not be construed to be a waiver or relinquishment of any such covenant, agreement or option, or any other covenant, agreement or option.

28. Assignment and Subletting. The Lessee shall not, without the prior written consent of the Lessor, let or sublet the whole or any part of the Premises, nor assign this lease or any part hereof without the written consent of the Lessor. Lessor may withhold its consent to any subletting or assignment of this lease or any portion thereof.

29. Successors. Subject to the provision hereof pertaining to assignment and subletting, the covenants and agreements of this lease shall be binding upon the legal representatives, successors and assigns of any or all of the parties hereto.

30. Disputes, Governing Law. This lease shall be construed in accordance with the laws of the State of Washington. Venue and jurisdiction of any disputes as to its terms shall be with the Pierce County Superior Court, Pierce County, Washington.

31. Notices. Notices required to be in writing under this lease shall be sent by registered or certified mail as follows:

If to Lessor:

KeyBank Corporate Real Estate Dept.  
1323 34<sup>th</sup> Ave E  
Fife, WA 98424

If to Lessee:

Public Works Director  
City of Gig Harbor  
3105 Judson Street  
Gig Harbor, WA 98335

32. Severability. If any section or provision of this lease shall be held by a court of competent jurisdiction to be unenforceable, this lease shall be construed as though such section or provision had not been included in it, and the remainder of the lease shall be enforced as the expression of the parties intentions. If any section or provision of this lease is found to be subject to two constructions, one of which would render such section or provision invalid and one of which would render such section or provision valid, then the latter construction shall prevail.

IN WITNESS WHEREOF, the parties have executed this instrument on the day and year first above written.

**LESSEE:**

THE CITY OF GIG HARBOR

**LESSOR:**

\_\_\_\_\_

By \_\_\_\_\_  
Its \_\_\_\_\_

By \_\_\_\_\_  
Its \_\_\_\_\_

APPROVED AS TO FORM:

By \_\_\_\_\_  
Gig Harbor City Attorney

ATTEST:

By \_\_\_\_\_  
Gig Harbor City Clerk

STATE OF WASHINGTON )  
 ) ss.  
COUNTY OF PIERCE )

I certify that I know or have satisfactory evidence that Gretchen A. Wilbert is the person who appeared before me and said person acknowledged that he/she signed this instrument, on oath stated that he/she was authorized to execute the instrument and acknowledged it as the Mayor of the City of Gig Harbor, a Washington municipal corporation, to be the free and voluntary act of such party for the uses and purposes mentioned in the instrument.

DATED this \_\_\_\_\_ day of \_\_\_\_\_, 1997.

\_\_\_\_\_  
\_\_\_\_\_  
(print or type name)  
NOTARY PUBLIC, State of Washington,  
residing in \_\_\_\_\_  
My commission expires \_\_\_\_\_

STATE OF \_\_\_\_\_ )  
 ) ss.  
COUNTY OF \_\_\_\_\_ )

I certify that I know or have satisfactory evidence that \_\_\_\_\_ is the person who appeared before me and said person acknowledged that he/she signed this instrument, on oath stated that he/she was authorized to execute the instrument and acknowledged it as the \_\_\_\_\_ of \_\_\_\_\_, a \_\_\_\_\_ corporation, to be the free and voluntary act of such party for the uses and purposes mentioned in the instrument.

DATED this \_\_\_\_\_ day of \_\_\_\_\_, 1997.

\_\_\_\_\_  
\_\_\_\_\_  
(print or type name)  
NOTARY PUBLIC, State of Washington,  
residing in \_\_\_\_\_  
My commission expires \_\_\_\_\_

Exhibit 'A'

LEGAL DESCRIPTION

BEGINNING AT THE SOUTHWEST CORNER OF SOUTHWEST QUARTER OF NORTHEAST QUARTER OF NORTHWEST QUARTER OF SECTION 8, TOWNSHIP 21 NORTH, RANGE 2 EAST, WILLAMETTE MERIDIAN, THENCE RUNNING EAST 146.47 FEET ON THE SOUTH LINE OF SAID SOUTHWEST QUARTER OF NORTHEAST QUARTER OF NORTHWEST QUARTER OF SECTION 8, TOWNSHIP 21 NORTH, RANGE 2 EAST, WILLAMETTE MERIDIAN TO THE CENTER LINE OF PIONEER WAY ALSO KNOWN AS WOLLOCHET GIG-HARBOR COUNTY ROAD, THENCE RUNNING EAST 38.05 FEET ALONG SAME SOUTH LINE OF THE SOUTHWEST QUARTER OF NORTHEAST QUARTER OF NORTHWEST QUARTER OF SECTION 8, TOWNSHIP 21 NORTH, RANGE 2 EAST, WILLAMETTE MERIDIAN TO THE SOUTH WEST CORNER OF LOT 8 OF THE PETER SKANSI ADDITION TO GIG HARBOR, THENCE NORTHEASTERLY ALONG THE WESTERN LINE OF LOTS 8, 9 AND 10 OF THE SAME PETER SKANSI ADDITION TO GIG HARBOR, ALSO THE SOUTH SIDE OF PIONEER WAY, TO THE SOUTHWEST CORNER OF LOT 11, THE TRUE POINT OF BEGINNING, THENCE NORTHEASTERLY 100 FEET ALONG THE SAME SOUTH LINE OF PIONEER WAY, THENCE SOUTH 0° 00' 10" WEST 70.71 FEET TO THE INTERSECTION OF THE SOUTH LINE OF LOT 11 OF THE SAME PETER SKANSI ADDITION TO GIG HARBOR, THENCE 70.71 FEET WEST ALONG SAID SOUTH LINE OF LOT 11 TO BEGINNING, AND CONTAINING 0.057 ACRES MORE OR LESS.

Exhibit 'B'

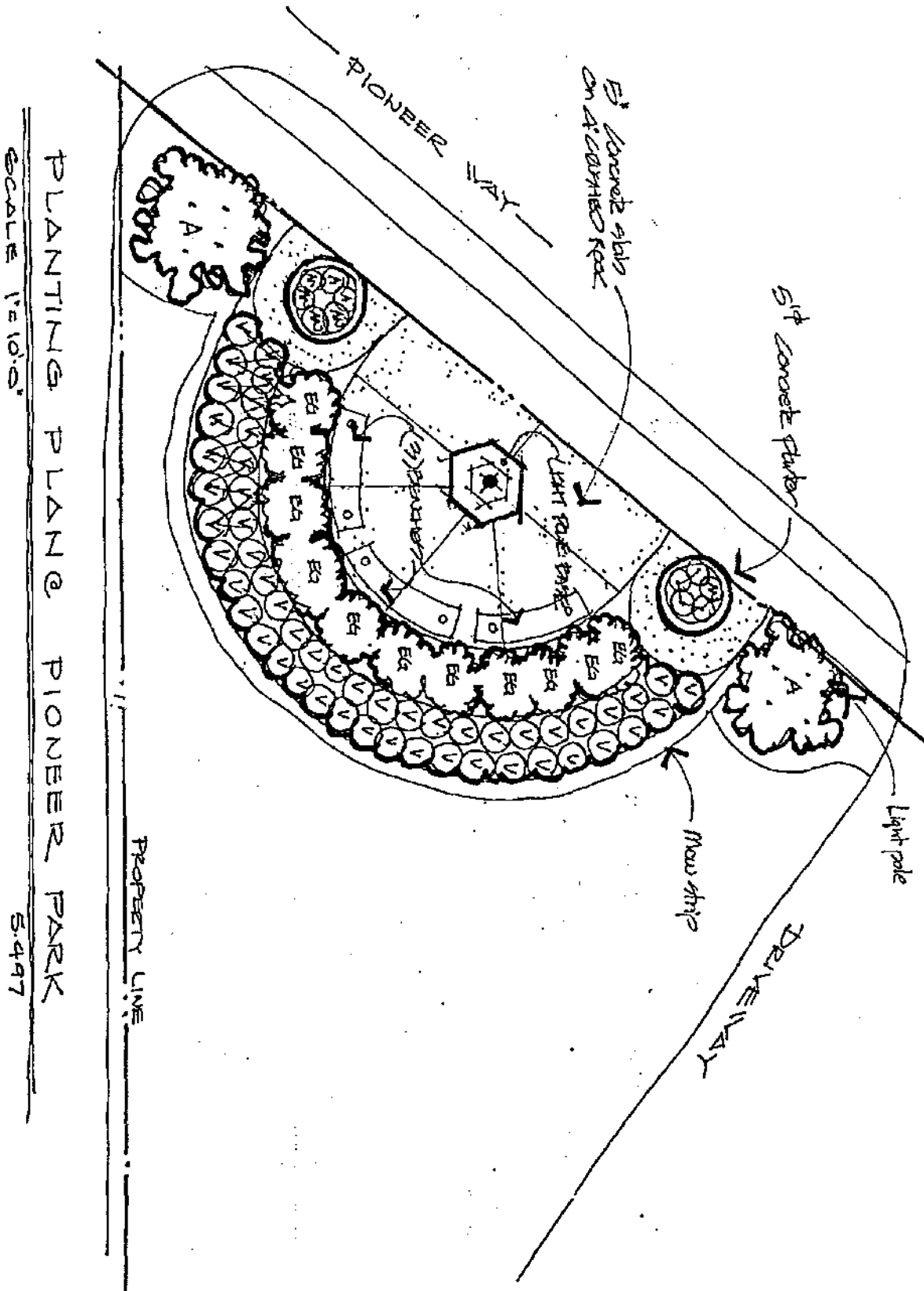

PLANTING PLANG PIONEER PARK

SCALE 1/2"=10'-0"

5497

Exhibit 'C'

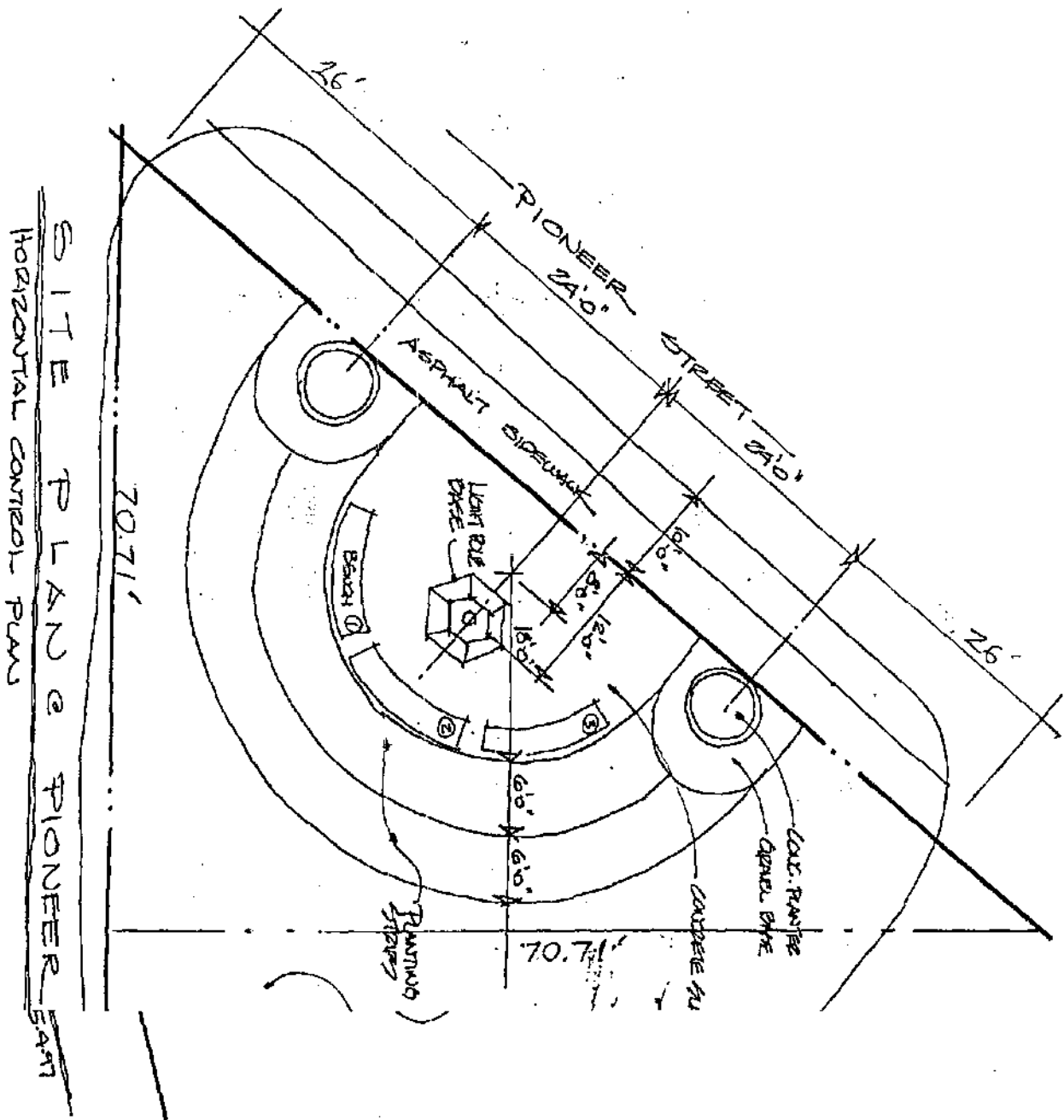

SITE PLAN of PIONEER BARN  
HORIZONTAL CONTROL PLAN





*City of Gig Harbor. The "Maritime City."*

3105 JUDSON STREET  
GIG HARBOR, WASHINGTON 98335  
(253) 851-8136

**TO: MAYOR WILBERT, CITY COUNCILMEMBERS**  
**FROM: CAROL MORRIS, CITY ATTORNEY**  
**SUBJECT: FIRST READING OF ORDINANCE - TELECOMMUNICATIONS -**  
**USE OF PUBLIC PROPERTY**  
**DATE: JULY 9, 1997**

#### **INFORMATION/BACKGROUND**

On October 29, 1996, the Gig Harbor City Council imposed a one-year moratorium on the permitting for the siting of telecommunications facilities in the City. Ordinance 739 was passed to allow the City staff, Planning Commission and City Council sufficient time to develop a telecommunications ordinance(s) consistent with the Telecommunications Act of 1996, and the City's interest in zoning and management of public rights-of-way.

#### **POLICY CONSIDERATIONS**

##### Distinction between the two proposed telecommunications ordinances.

An ordinance was developed to address siting of telecommunications facilities on private property, which has been reviewed by the City Planning Commission. The attached ordinance (adding a new Chapter 12.18 to the Gig Harbor Municipal Code) establishes requirements for telecommunication carriers' and cable operators' use of the public rights-of-way and other public property.

##### Summary of telecommunications ordinance.

The attached telecommunications ordinance requires that telecommunications carriers and cable operators obtain business licenses and that they obtain the applicable permission to use the public right-of-way, by either franchise, right-of-way permit or lease. In addition, the ordinance describes violations and contains an enforcement mechanism which includes civil and criminal penalties.

##### Consistency with Telecommunications Act of 1996.

A. Discriminatory or Prohibitory Actions. Under the Telecommunications Act, the City may not adopt a regulation which prohibits, or has the effect of prohibiting, the ability of any entity to provide any interstate or intrastate telecommunications service. (47 U.S.C. § 332(c)(7)(B)(i).

B. Compensation for Use of Public Property. Nothing in the Act affects the authority of the City to "manage the public rights-of-way or to require fair and reasonable compensation from telecommunications providers, on a competitively neutral and nondiscriminatory basis, for use of public rights-of-way on a nondiscriminatory basis, if the compensation required is publicly disclosed by such government." (Id.)

C. City Action on Applications. The City is required to act on a request for authorization to place, construct or modify personal wireless service facilities within a reasonable time. 47 U.S.C. § 332(c)(7)(B)(ii), (iii). Any decision to deny a request must be made in writing and be supported by substantial evidence contained in a written record. (Id.) A person adversely affected by the City's action or failure to act that is inconsistent with 47 U.S.C. § 332(c)(7) may seek expedited review in the courts. (47 U.S.C. § 332(c)(7)(B)(v).)

D. Regulations Based on Environmental Effects of RF Emissions Preempted. The Act expressly preempts the City's regulation of the placement, construction and modification of personal wireless service facilities on the basis of the environmental effects of radio frequency emissions to the extent that such facilities comply with the FCC's regulations concerning such emissions. 47 U.S.C. § 332(c)(7)(B)(iv).

Staff believes that the attached ordinance is consistent with the Telecommunications Act and all of the above.

#### **RECOMMENDATION**

This is the first reading of the telecommunications ordinance adopting a new chapter 12.18 to the Gig Harbor Municipal Code. No action is requested at this time.

The City's telecommunications moratorium will expire on October 29, 1997. Therefore, the City Council will be required to take final action on this ordinance at its meeting of October 22, 1997.

ORDINANCE NO. \_\_\_\_\_

**AN ORDINANCE OF THE CITY OF GIG HARBOR, WASHINGTON, RELATING TO TELECOMMUNICATIONS AND CABLE TELEVISION; ESTABLISHING REQUIREMENTS FOR TELECOMMUNICATION CARRIERS' AND CABLE OPERATORS' USE OF THE PUBLIC RIGHTS-OF-WAY AND PUBLIC PROPERTY; DESCRIBING THE PROCEDURES FOR APPLICATION AND APPROVAL OF TELECOMMUNICATION BUSINESS LICENSES, TELECOMMUNICATIONS RIGHT-OF-WAY USE PERMITS, FRANCHISES AND CABLE TELEVISION FRANCHISES; DESCRIBING VIOLATIONS AND ESTABLISHING PENALTIES; AND ADDING A NEW CHAPTER 12.18 TO THE GIG HARBOR MUNICIPAL CODE.**

---

WHEREAS, RCW 35A.11.020 grants code cities broad authority to regulate the use of the public rights-of way; and

WHEREAS, RCW 35A.47.040 grants code cities broad authority to grant non-exclusive franchise agreements; and

WHEREAS, Congress has adopted the Telecommunications Act of 1996 (hereinafter the "Act") in order to encourage the development of high-technology communications systems through increased competition among communications companies; and

WHEREAS, the Act provides for the removal of regulatory barriers, rate deregulation and relaxation of certain anti-trust provisions in an attempt to achieve this goal; and

WHEREAS, the Act is anticipated to have a significant effect on the manner in which communications services are delivered, and local telephone companies and cable television companies will all be able to provide telephone, data, video and other communications services; and

WHEREAS, the Act contains numerous provisions which directly affect local taxation, zoning, franchise authority and public rights-of-way management; and

WHEREAS, the Act will likely place additional demands on the use of the City's public rights-of-way and public property; and

WHEREAS, the City currently has regulations which do not adequately address the use of public rights-of-way for telecommunication purposes; now therefore,

Section 1. A new chapter 12.18 is hereby added to the Gig Harbor Municipal Code, to read as follows:

**CHAPTER 12.18  
TELECOMMUNICATIONS**

**ARTICLE I.  
GENERAL PROVISIONS**

<b>Sections</b>	<b>12.18.010</b>	<b>Purpose.</b>
	<b>12.18.020</b>	<b>Definitions.</b>
	<b>12.18.030</b>	<b>Business License Required.</b>
	<b>12.18.040</b>	<b>Telecommunications Right-of-Way Permit Required.</b>
	<b>12.18.050</b>	<b>Telecommunications Franchise Required.</b>
	<b>12.18.060</b>	<b>Cable Television Franchise Required.</b>
	<b>12.18.070</b>	<b>Facilities Lease Required.</b>
	<b>12.18.080</b>	<b>Construction Permit Required.</b>
	<b>12.18.090</b>	<b>Application to Existing Franchise Ordinances, Agreements, Leases, and Permits -- Effect of Other Laws.</b>
	<b>12.18.0100</b>	<b>General Penalties.</b>
	<b>12.18.0110</b>	<b>Other Remedies.</b>

**Section 12.18.0101: Purpose.** The purpose and intent of this Chapter is to:

- establish a local policy concerning telecommunications providers and service;
- establish clear local guidelines, standards and time frames for the exercise of local authority with respect to the regulation of telecommunications providers and services;
- promote competition in telecommunications;
- minimize unnecessary local regulation of telecommunications providers and services;
- encourage the provision of advanced and competitive telecommunications services on the widest possible basis to the businesses, institutions and residents of the City;
- permit and manage reasonable access to the public ways of the City for telecommunications purposes on a competitively neutral basis;

- conserve the limited physical capacity of the public ways held in public trust by the City;
- assure that the City's current and ongoing costs of granting and regulating private access to and use of the public ways are fully paid by the persons seeking such access and causing such costs;
- secure fair and reasonable compensation to the City and the residents of the City for permitting private use of the public ways;
- assure that all telecommunications carriers providing facilities or services within the City comply with the ordinances, rules and regulations of the City;
- assure that the City can continue to fairly and responsibly protect the public health, safety and welfare;
- enable the City to discharge its public trust consistent with rapidly evolving federal and state regulatory policies, industry competition and technological development.

**Section 12.18.0102: Definitions.** For the purpose of this Chapter, and the interpretation and enforcement thereof, the following words and phrases shall have the following meanings, unless the context of the sentence in which they are used shall indicate otherwise:

*"Access channels"* means channels set aside by a franchisee exclusively for noncommercial public, educational, or governmental use (commonly referred to as "PEG" channels).

*"Addressability"* means the ability of a system allowing a franchisee to authorize specific equipment to receive, change or to cancel any or all specified programming.

*"Affiliate"* means a person that (directly or indirectly) owns or controls, is owned or controlled by, or is under common ownership or control with another person.

*"Applicant"* means any person or entity that applies for any permit or franchise pursuant to this Chapter.

*"Basic cable service"* means the lowest level of service regularly provided to all Subscribers that includes the retransmission of local broadcast signals.

*"Cable Act"* shall mean the Cable Communications Policy Act of 1984, 47 U.S.C. §532, *et seq.*, as now and hereafter amended.

*"Cable facilities"* means equipment and wiring used to transmit audio and video signals to subscribers.

**"Cable operator"** means a telecommunications carrier providing or offering to provide "cable service" within the City as that term is defined in the Cable Act.

**"Cable service"** for the purpose of this Chapter shall have the same meaning provided by the Cable Act.

**"Cable system"** means a facility, consisting of a set of closed transmission paths and associated signal generation, reception, and control equipment that is designed to provide cable service and other service to subscribers.

**"Cablecast"** means the distribution of programming which originates within the facilities of the cable television system.

**"Channel" or "cable channel"** means a portion of the electromagnetic frequency spectrum which is used in a cable system and which is capable of delivering a television signal as defined by the Federal Communications Commission.

**"Character generator"** means a device used to generate alpha numerical programming to be cablecast on a cable channel.

**"City"** means the City of Gig Harbor, Washington.

**"City property"** means and includes all real property owned by the City, other than public streets and utility easements as those terms are defined herein, and all property held in a proprietary capacity by the City, which are not subject to right-of-way licensing and franchising as provided in this Chapter.

**"Council"** means the City Council of the City of Gig Harbor, Washington acting in its official capacity.

**"Data communication"** means (1) the transmission of encoded information or (2) the transmission of data from one point to another.

**"Dwelling units"** means residential living facilities as distinguished from temporary lodging facilities such as hospitals, hotel and motel rooms and dormitories, and includes single family residential units and individual apartments, condominium units, mobile homes, extended care facilities and other multiple family residential units.

**"Emergency"** means a condition of imminent danger to the health, safety, and welfare of property or persons located within the City including, without limitation, damage to persons or property from natural consequences, such as storms, earthquakes, riots or wars.

**"Excess capacity"** means the volume or capacity in any existing or future duct, conduit, manhole, handhole or other utility facility within the public way that is or will be available for use for additional telecommunications facilities.

**"FCC"** or **"Federal Communications Commission"** means the Federal administrative agency, or lawful successor, authorized to regulate and oversee telecommunications carriers, services and providers on a national level.

**"Fiber Optics"** means the technology of guiding and projecting light for use as a communications medium.

**"Franchise"** shall mean the initial authorization, or renewal thereof, issued by the franchising authority, whether such authorization is designated as a franchise, permit, Ordinance, resolution, contract, certificate or otherwise, which authorizes construction and operation of the cable system for the purpose of offering cable service or other service to subscribers.

**"Franchisee"** means the person, firm or corporation to whom or which a franchise, as herein above defined, is granted by the Council under this Chapter and the lawful successor, transferee or assignee of said person, firm or corporation subject to such conditions as may be defined in this Chapter.

**"Gross revenues"** means any and all revenues (as that term is defined by generally accepted accounting principles) received directly or indirectly from all sources which arise out of or are derived from the operation of a franchisee's cable system in the City. When the revenue of the franchisee includes gross revenues from sources outside of the City, a franchisee shall prorate the gross revenues among its sources by multiplying such gross revenues by a fraction, the numerator of which is the number of franchisee's subscribers in the City and the denominator of which is the total number of all a franchisee's subscribers. "Gross revenues" shall not include the following:

1. Fees and payments from subscribers who do not live in the City;
2. Taxes on services furnished by a franchisee, which are imposed on any subscriber or used by any governmental unit, agency or instrumentality and which are collected by a franchisee for such entity;
3. Bad debt write-offs;
4. Revenue from the sale of equipment or other assets of the cable system to persons not purchasing services from the cable system;
5. Revenue from transactions involving real property owned or leased by the franchisee;
6. Amounts collected from subscribers as a franchise fee to be paid to City.

**"Headend"** means the electronic equipment located at the start of a cable system, usually including antennas, preamplifiers, frequency converters, demodulators and related equipment.

**"Installation"** means the connection of the cable system from feeder cable to subscribers' receivers.

**"Institutional networks (I-Nets)"** means that portion of a cable system which is designated principally for the provision of non-entertainment services to public schools, or public agencies such as public libraries separate and distinct from the subscriber network, or on secured channels of the subscriber network.

**"Interactive services"** means services provided to subscribers where the subscriber (i) receives information consisting of either television or other signals and transmits signals generated by the subscriber or equipment under his/her control for the purpose of selecting what information shall be transmitted to the subscriber or for any other purpose; and (ii) has the ability to transmit signals to any other location for any purpose.

**"Office"** means the person or entity designated by the City as being responsible for the administration of a franchise for the City.

**"Operator"** means the person, firm or corporation to whom a franchise is granted pursuant to the provisions of this Chapter.

**"Other ways"** means the highways, streets, alleys, utility easements or other rights-of-way within the City, but under the jurisdiction and control of a governmental entity other than the City.

**"Overhead facilities"** means utility poles, utility facilities and telecommunications facilities located above the surface of the ground, including the underground supports and foundations for such facilities.

**"Person"** means and includes corporations, companies, associations, joint stock companies or associations, firms, partnerships, limited liability companies and individuals and includes their lessors, trustees and receivers.

**"Premium services"** means video programming offered on a pay-per-channel or pay-per-program basis.

**"Property of franchisee"** means all property owned, installed or used by a Franchisee in the conduct of its business in the City under the authority of a franchise granted pursuant to this Chapter.

**"Proposal"** means the response, by an individual or organization, to a request by the City regarding the provision of cable services; or an unsolicited plan submitted by an individual or organization seeking to provide cable services in the City.

**"Public street"** means any highway, street, alley or other public right of way for motor vehicle travel under the jurisdiction and control of the City which has been acquired,



established, dedicated or devoted to highway purposes not inconsistent with telecommunications facilities.

**"Public way** means and includes all public streets and utility easements, as those terms are defined herein, now or hereafter owned by the City, but only to the extent of the City's right, title, interest or authority to grant a license or franchise to occupy and use such streets and easements for telecommunications facilities.

**"State"** means the State of Washington.

**"Subscriber"** means a person or entity or user of the cable system who lawfully receives cable services or other service therefrom with franchisee's express permission.

**"Surplus space"** means that portion of the usable space on a utility pole which has the necessary clearance from other pole users, as required by the federal or state orders and regulations, to allow its use by a telecommunications carrier for a pole attachment.

**"Telecommunications carrier"** means and includes every person that directly or indirectly owns, controls, operates or manages plan, equipment or property within the City, used or to be used for the purpose of offering telecommunications service.

**"Telecommunications facilities"** means the plant, equipment and property, including but not limited to, cables, wires, conduits, ducts, pedestals, antennae, electronics and other appurtenances used or to be used to transmit, receive, distribute, provide or offer telecommunications services.

**"Telecommunications provider"** means and includes every person who provides telecommunications services over telecommunications facilities without any ownership or management control of the facilities.

**"Telecommunications service"** means the providing or offering for rent, sale or lease, or in exchange for other value received, of the transmittal of voice, data, image, graphic and video programming information between or among points by wire, cable, fiber optics, laser, microwave, radio, satellite or similar facilities, with or without benefit of any closed transmission medium.

**"Telecommunications system"** See **"Telecommunications facilities"**.

**"Underground facilities"** means utility and telecommunications facilities located under the surface of the ground, excluding the underground foundations or supports for overhead facilities.

**"Usable space"** means the total distance between the top of a utility pole and the lowest possible attachment point that provides the minimum allowable vertical clearance as specified in any federal or state orders and regulations.

**"Utility easement"** means any easement owned by the City and acquired, established, dedicated or devoted for public utility purposes not inconsistent with telecommunications facilities.

**"Utility facilities"** means the plant, equipment and property, including but not limited to the poles, pipes, mains, conduits, ducts, cables, wires, plant and equipment located under, on or above the surface of the ground within the public ways of the City and used or to be used for the purpose of providing utility or telecommunications services.

**Section 12.18.0103: Business License Required.** Except as otherwise provided herein, all cable operators, telecommunications carriers, and telecommunications providers engaged in the business of transmitting, supplying or furnishing of cable service or telecommunications originating or terminating in the City shall apply for and obtain a business license with the City pursuant to Article II. of this Chapter.

**Section 12.18.0104: Telecommunications Right-of-Way Use Permit Required.** Except as otherwise provided herein, any telecommunications carrier who desires to construct, install, operate, maintain, or otherwise locate telecommunications facilities in, under, over or across any public way of the City for the sole purpose of providing telecommunications service to persons and areas outside the City shall first obtain a telecommunications right-of-way use permit granting the use of such public ways from the City pursuant to Article III. of this Chapter.

**Section 12.18.0105: Telecommunications Franchise Required.** Except as otherwise provided herein, any telecommunications carrier who desires to construct, install, operate, maintain or otherwise locate telecommunications facilities in, under, over or across any public way of the City, and to also provide telecommunications service to persons or areas in the City, shall first obtain franchise granting the use of such public ways from the City pursuant to Article IV. of this Chapter.

**Section 12.18.0106: Cable Television Franchise Required.** Except as otherwise provided herein, any telecommunications carrier or other person who desires to construct, install, operate, maintain or locate cable or telecommunications facilities in any public way in the City for the purpose of providing cable service to persons in the City shall first obtain a cable franchise from the City pursuant to Article V. of this Chapter.

**Section 12.18.0107: Facilities Lease Required.** No telecommunications carrier or other entity who desires to locate telecommunications or other equipment on City property shall locate such facilities or equipment on City property unless granted a Facilities Lease from the City. The City Council reserves unto itself the sole discretion to lease City property for telecommunications and other facilities, and no vested or other right shall be created by this Section or any provision of this Chapter applicable to such Facilities Leases.

**Section 12.18.0108: Construction Permits Required.** Except as otherwise provided herein, the holder of a permit or franchise granted pursuant this Chapter shall, in addition to said permit or franchise, be required to obtain a Construction Permit from the City pursuant to Article VII. of this Chapter. No work, construction, development, excavation, or installation of any

equipment or facilities shall take place within the public ways until such time as the Construction Permit is issued.

**Section 00.00.0109: Application to Existing Franchise Ordinances, Agreements, Leases, and Permits -- Effect of other Laws.**

A. This Chapter shall have no effect on any existing franchise ordinance, franchise agreement, lease, or permit to use or occupy a public way in the City until:

1. the expiration of said franchise ordinance, agreement, lease, or permit; or
2. the amendment to an unexpired franchise ordinance, franchise agreement, lease, or permit, unless both parties agree to defer full compliance to a specific date not later than the present expiration date.

B. Nothing in this Chapter shall be deemed to create an obligation upon any person for which the City is forbidden to require a permit, license, or franchise by federal, state, or other law.

**Section 12.18.0110: General Penalties.**

**A. Penalty.**

1. Any person, and the officers, directors, managing agents, or partners of any corporation, firm, partnership or other organization or business violating or failing to comply with any of the provisions of this Chapter shall be subject to a cumulative penalty in the amount of five hundred Dollars (\$500) per day for each violation from the date set for compliance until compliance with this Chapter is achieved.

2. In addition to any penalty which may be imposed by the City, any person violating or failing to comply with any of the provisions of this Chapter shall be liable for all damage to public or private property arising from such violation, including the cost of restoring the affected area to its condition prior to the violation.

3. The penalty imposed by this section shall be collected by civil action brought in the name of the City. The City Administrator shall notify the City Attorney in writing of the name of any person subject to the penalty, and the City Attorney shall, with the assistance of the City Administrator, take appropriate action to collect the penalty.

4. The violator may show as full or partial mitigation of liability:

- a. That the violation giving rise to the action was caused by the wilful act, or neglect, or abuse of another; or

- b. That correction of the violation was commenced promptly upon receipt of the notice thereof, but that full compliance within the time specified was prevented

by inability to obtain necessary materials or labor, inability to gain access to the subject structure, or other condition or circumstance beyond the control of the violator.

**B. Criminal Penalties.**

1. Any person, and the officers, directors, managing agents, or partners of any corporation, firm, partnership or other organization or business violating or failing to comply with any of the applicable provisions of this Chapter and who has had a judgment entered against him or her pursuant to Section 12.18.100(A)(3) or its predecessors within the past five (5) years shall be subject to criminal prosecution and upon conviction of a subsequent violation shall be fined in a sum not exceeding Five Thousand Dollars (\$5,000.00) or be imprisoned for a term not exceeding one (1) year or be both fined and imprisoned. Each day of noncompliance with any of the applicable provisions of the Chapter shall constitute a separate offense.

2. The above criminal penalty may also be imposed:

a. For any other violation of this Chapter for which corrective action is not possible;

b. For any wilful, intentional, or bad faith failure or refusal to comply with the standards or requirements of this Chapter; and

c. For any violation of a stop work or other order issued pursuant to this Chapter.

3. In addition to any criminal penalty which may be imposed by the City, a violator may also be liable for damages and costs of restoration described in subsection 12.18.100(A), above.

**C. Additional Relief.** The City may request that the City Attorney seek legal or equitable relief to enjoin any acts or practices and abate any condition which constitutes or will constitute a violation of the applicable provisions of this Chapter when civil or criminal penalties are inadequate to effect compliance.

**Section 12.18.0111: Other Remedies.** Nothing in this Chapter shall be construed as limiting any judicial remedies that the City may have, at law or in equity, for enforcement of this Chapter.

**ARTICLE II.  
BUSINESS LICENSING OF TELECOMMUNICATIONS  
CARRIERS AND PROVIDERS**

<b>Section</b>	<b>12.18.0120</b>	<b>Purpose of Business License Registration.</b>
	<b>12.18.0130</b>	<b>Business License Required.</b>
	<b>12.18.0140</b>	<b>Business License Fees.</b>

**Section 12.18.0112: Purpose of Business License Registration.** The purpose of telecommunications business licensing is to:

- A.** provide the City with accurate and current information concerning the cable operators and telecommunications carriers and providers who offer or provide services within the City, or that own or operate facilities within the City;
- B.** assist the City in enforcement of this Chapter;
- C.** assist the City in the collection and enforcement of any municipal taxes, franchise fees, license fees or charges that may be due the City;
- D.** assist the City in monitoring compliance with local, State and Federal laws.

**Section 12.18.0113: Business License Required.** All cable operators, telecommunications carriers, and telecommunications providers that offer or provide any cable service or telecommunications service for a fee directly to the public, either within the City, or outside the corporate limits from cable or telecommunications facilities within the City, shall apply for and obtain a business license with the City pursuant to this Chapter on forms to be provided by the City Administrator, which shall include the following:

- A.** The identity and legal status of the applicant, including any affiliates.
- B.** The name, address, telephone number, and title of the officer, agent or employee responsible for the accuracy of the business license application statement.
- C.** A description of applicant's existing or proposed facilities within the City.
- D.** A description of the service that the applicant intends to offer or provide, or is currently offering or providing, to persons, firms, businesses or institutions within the City.
- E.** Information sufficient to determine whether the applicant is subject to the public way permitting and/or franchising requirements imposed by this Chapter.
- F.** Information sufficient to determine whether the transmission, origination or receipt of the services provided or to be provided by the applicant constitutes an occupation or

privilege subject to any municipal telecommunications tax, utility tax or other occupation tax imposed by the City.

**G.** Information sufficient to determine that the applicant has applied for and received any certificate of authority required by any federal or state agency to provide telecommunications services or facilities within the City.

**H.** Information sufficient to determine that the applicant has applied for and received any construction permit, operating license or other approvals required by the Federal Communications Commission to provide services or construct facilities within the City.

**Section 12.18.0114: Business License Fees.** Each application for a business license as a cable operator or telecommunications carrier or provider shall be accompanied by an application fee which shall be set by the City Council by resolution.

**ARTICLE III.  
TELECOMMUNICATIONS RIGHT-OF-WAY USE PERMITS**

<b>Sections</b>	<b>12.18.0150</b>	<b>Telecommunications Right-of-Way Use Permit.</b>
	<b>12.18.0160</b>	<b>Telecommunications Right-of-Way Use Permit Application.</b>
	<b>12.18.0170</b>	<b>Issuance/Denial of Telecommunications Right-of-Way Use Permit.</b>
	<b>12.18.0180</b>	<b>Agreement.</b>
	<b>12.18.0190</b>	<b>Nonexclusive Grant.</b>
	<b>12.18.0200</b>	<b>Rights Granted.</b>
	<b>12.18.0210</b>	<b>Terms of Telecommunications Right-of-Way Use Permit.</b>
	<b>12.18.0220</b>	<b>Telecommunications Right-of-Way Use Permit Route.</b>
	<b>12.18.0230</b>	<b>Service to City Users.</b>
	<b>12.18.0240</b>	<b>Compensation to the City.</b>
	<b>12.18.0250</b>	<b>Amendment of Permit.</b>
	<b>12.18.0260</b>	<b>Renewal of Telecommunications Right-of-Way Use Permit.</b>
	<b>12.18.0270</b>	<b>Standards for Renewal of Permits.</b>
	<b>12.18.0280</b>	<b>Obligation to Cure as a Condition of Renewal.</b>

**Section 12.18.0115: Telecommunications Right-of-Way Use Permit.** A telecommunications right-of-way permit shall be required of any telecommunications carrier who desires to occupy specific public ways of the City for the sole purpose of providing telecommunications services to persons or areas outside the City.

**Section 12.18.0116: Telecommunications Right-of-Way Use Permit Application.** Any person that desires a telecommunications right-of-way use permit pursuant to this Chapter shall file an application with the City which shall include the following information:

**A.** The identity of the applicant, including all affiliates of the applicant.

**B.** A description of the telecommunications services that are or will be offered or provided by the applicant over its telecommunications facilities.

**C.** A description of the transmission medium that will be used by the applicant to offer or provide such telecommunications services.

**D.** Preliminary engineering plans, specifications and a network map of the facilities to be located within the City, all in sufficient detail to identify:

- (1) the location and route requested for applicant's proposed telecommunications facilities;
- (2) the location of all overhead and underground public utility, telecommunication, cable, water, sewer drainage and other facilities in the public way along the proposed route;
- (3) the location(s), if any, for interconnection with the telecommunications facilities of other telecommunications carriers;
- (4) the specific trees, structures, improvements, facilities and obstructions, if any, that applicant proposes to temporarily or permanently remove or relocate.

**E.** If applicant is proposing to install overhead facilities, evidence that surplus space is available for locating its telecommunications facilities on existing utility poles along the proposed route.

**F.** If applicant is proposing an underground installation in existing ducts or conduits within the public ways, information in sufficient detail to identify:

- (1) the excess capacity currently available in such ducts or conduits before installation of applicant's telecommunications facilities;
- (2) the excess capacity, if any, that will exist in such ducts or conduits after installation of applicant's telecommunications facilities.

**G.** If applicant is proposing an underground installation within new ducts or conduits to be constructed within the public ways:

- (1) the location proposed for the new ducts or conduits;
- (2) the excess capacity that will exist in such ducts or conduits after installation of applicant's telecommunications facilities.

- H. A preliminary construction schedule and completion date.
- I. A preliminary traffic control plan in accordance with the City's adopted street standards.
- J. Financial statements prepared in accordance with generally accepted accounting principles demonstrating the applicant's financial ability to construct, operate, maintain, relocate and remove the facilities.
- K. Information in sufficient detail to establish the applicant's technical qualifications, experience and expertise regarding the telecommunications facilities and services described in the application.
- L. Information to establish that the applicant has obtained all other governmental approvals and permits to construct and operate the facilities, and to offer or provide the telecommunications services.
- M. All deposits or charges required pursuant to this Chapter.
- N. An application fee which shall be set by the City Council by resolution.

**Section 12.18.0117: Issuance/Denial of Telecommunications Right-of-Way Use Permit.** Within 120 days after receiving a complete application under Section 12.18.0160 hereof, the City shall issue a written determination granting or denying the permit in whole or in part. Prior to granting or denying a permit under this Article, the City Council shall conduct a public hearing and make a decision based upon the following standards. If the permit is denied, the written determination shall include the reason(s) for denial.

- A. The financial and technical ability of the applicant.
- B. The legal ability of the applicant.
- C. The capacity of the public ways to accommodate the applicant's proposed facilities.
- D. The capacity of the public ways to accommodate additional utility, cable, and telecommunications facilities if the permit is granted.
- E. The damage or disruption, if any, of public or private facilities, improvements, service, travel or landscaping if the permit is granted.
- F. The public interest in minimizing the cost and disruption of construction within the public ways.
- G. The service that applicant will provide to the community and region.



- H. The effect, if any, on public health, safety and welfare if the license is granted.
- I. The availability of alternate routes and/or locations for the proposed facilities.
- J. Applicable federal and state telecommunications laws, regulations and policies.
- K. Such other factors as may demonstrate that the grant to use the public ways will serve the community interest.

**Section 12.18.0118: Agreement.** No permit shall be deemed to have been granted hereunder until the applicant and the City have executed a written agreement setting forth the particular terms and provisions under which the permittee has been granted to right to occupy and use public ways of the City.

**Section 12.18.0119: Nonexclusive Grant.** No permit granted under this Article shall confer any exclusive right, privilege, license or franchise to occupy or use the public ways of the City for delivery of telecommunications services or any other purposes.

**Section 12.18.0120: Rights Granted.** No permit granted under this Article shall convey any right, title or interest in the public ways, but shall be deemed a permit only to use and occupy the public ways for the limited purposes and term stated in the permit. Further, no permit shall be construed as any warranty of title.

**Section 12.18.0121: Terms of Telecommunications Right-of-Way Use Permit.** Unless otherwise specified in a permit, a telecommunications permit granted hereunder shall be in effect for a term of one (1) year, which shall be revokable upon thirty (30) days notice by the City to the permittee.

**Section 12.18.0122: Telecommunications Right-of-Way Permit Route.** A telecommunications permit granted under this Article shall be limited to a grant of specific public ways and defined portions thereof.

**Section 12.18.0123: Service to City Users.** A permittee shall be permitted to offer or provide telecommunications services to persons or areas within the City upon approval of an application for a telecommunications franchise pursuant to Article IV. of this Chapter.

**Section 12.18.0124: Compensation to the City.** Each permit granted pursuant to this Article is subject to the City's right, which is expressly reserved, to annually fix a fair and reasonable compensation to be paid for the right to occupy and use the public ways of the City granted under such permits; provided, nothing in this Chapter shall prohibit the City and a permittee from agreeing to the compensation to be paid.

**Section 12.18.0125: Amendment of Permit.** A new permit application shall be required of any telecommunications carrier that desires to extend or locate its telecommunications facilities in public ways of the City which are not included in a permit previously granted under this Chapter. If ordered by the City to locate or relocate its telecommunications facilities in public ways not included in a previously granted license, the City shall grant a permit amendment without further application.

**Section 12.18.0126: Renewal of Telecommunications Right-of-Way Use Permit.** A permittee that desires to renew its permit under this Article shall, not more than 180 days nor less than 90 days before expiration of the current permit, file an application with the City for renewal of its permit which shall include the following:

- A. The information required pursuant to Section 12.18.0160 of this Chapter.
- B. Any information required pursuant to the permit agreement between the City and the permittee.
- C. All deposits or charges required pursuant to this Chapter.
- D. An application fee which shall be set by the City Council by resolution.

**Section 12.18.0127: Standards for Renewal of Permits.** Within 90 days after receiving a complete application for permit renewal, the City shall issue a written determination granting or denying the renewal application in whole or in part. Prior to granting or denying the renewal of a permit under this Article, the City Council shall conduct a public hearing and make a decision based upon the following standards. If the renewal application is denied, the written determination shall include the reasons for non-renewal.

- A. The financial and technical ability of the applicant.
- B. The continuing capacity of the public ways to accommodate the applicant's existing facilities.
- C. The applicant's compliance with the requirements of this Chapter and the permit.
- D. Applicable federal, state and local telecommunications laws, rules and policies.
- E. Such other factors as may demonstrate that the continued grant to use the public ways will serve the community interest.

**Section 12.18.0128: Obligation to Cure as a Condition of Renewal.** No permit shall be renewed until any ongoing violations or defaults in the permittee's performance of the permit, or of

the requirements of this Chapter, have been cured, or a plan detailing the corrective action to be taken by the permittee has been approved by the City.

**ARTICLE IV.  
TELECOMMUNICATIONS FRANCHISE**

<b>Sections</b>	<b>12.18.290</b>	<b>Telecommunications Franchise.</b>
	<b>12.18.300</b>	<b>Franchise Application.</b>
	<b>12.18.310</b>	<b>Determination by the City.</b>
	<b>12.18.320</b>	<b>Agreement.</b>
	<b>12.18.330</b>	<b>Nonexclusive Grant.</b>
	<b>12.18.340</b>	<b>Terms of Franchise Grant.</b>
	<b>12.18.350</b>	<b>Rights Granted.</b>
	<b>12.18.360</b>	<b>Franchise Territory.</b>
	<b>12.18.370</b>	<b>Compensation to the City.</b>
	<b>12.18.380</b>	<b>Nondiscrimination.</b>
	<b>12.18.390</b>	<b>Amendment of Franchise Grant.</b>
	<b>12.18.400</b>	<b>Renewal Application.</b>
	<b>12.18.410</b>	<b>Renewal Determination.</b>
	<b>12.18.420</b>	<b>Obligation to Cure as Condition of Renewal.</b>

**Section 12.18.0129: Telecommunications Franchise.** A telecommunications franchise shall be required of any telecommunications carrier or other person who desires to occupy public ways of the City and to provide telecommunications services to any person or area in the City.

**Section 12.18.0130: Franchise Application.** Any person that desires a telecommunications franchise pursuant to this Chapter shall file an application with the City which shall include the following:

- A. The identity of the applicant, including all affiliates of the applicant.
- B. A description of the services that are or will be offered or provided by the applicant over its existing or proposed facilities.
- C. A description of the transmission medium that will be used by the franchisee to offer or provide such services.
- D. Preliminary engineering plans, specifications and a network map of the facilities to be located within the City, all in sufficient detail to identify:
  - (1) the location and route requested for applicant's proposed facilities.

- (2) the location of all overhead and underground public utility, telecommunication, cable, water, sewer drainage and other facilities in the public way along the proposed route.
- (3) the location(s), if any, for interconnection with the facilities of other telecommunications carriers and cable operators.
- (4) the specific trees, structures, improvements, facilities and obstructions, if any, that applicant proposes to temporarily or permanently remove or relocate.

**E.** If applicant is proposing to install overhead facilities, evidence that surplus space is available for locating its facilities on existing utility poles along the proposed route.

**F.** If applicant is proposing an underground installation in existing ducts or conduits within the public ways, information in sufficient detail to identify:

- (1) the excess capacity currently available in such ducts or conduits before installation of applicant's facilities;
- (2) the excess capacity, if any, that will exist in such ducts or conduits after installation of applicant's facilities.

**G.** If applicant is proposing an underground installation within new ducts or conduits to be constructed within the public ways:

- (1) the location proposed for the new ducts or conduits;
- (2) the excess capacity that will exist in such ducts or conduits after installation of applicant's facilities.

**H.** A preliminary construction schedule and completion dates.

**I.** A preliminary traffic control plan in accordance with the City's adopted street standards.

**J.** Financial statements prepared in accordance with generally accepted accounting principles demonstrating the applicant's financial ability to construct, operate, maintain, relocate and remove the facilities.

**K.** Information in sufficient detail to establish the applicant's technical qualifications, experience and expertise regarding the facilities and services described in the application.

L. Information to establish that the applicant has obtained all other governmental approvals and permits to construct and operate the facilities and to offer or provide the telecommunications or other services.

M. Whether the applicant intends to provide cable service, video dialtone service or other video programming service, and sufficient information to determine whether such service is subject to cable franchising.

N. An accurate map showing the location of any existing telecommunications facilities in the City that applicant intends to use or lease.

O. A description of the services or facilities that the applicant will offer or make available to the City and other public, educational and governmental institutions.

P. A description of applicant's access and line extension policies.

Q. The area or areas of the City the applicant desires to serve and a schedule for build-out to the entire franchise area.

R. All fees, deposits or charges required pursuant to Article VI. of this Chapter.

S. Such other and further information as may be requested by the City Administrator.

T. An application fee which shall be set by the City Council by resolution.

**Section 12.18.0131: Determination by the City.** Within 120 days after receiving a complete application under Section 12.18.0300 hereof, the City shall issue a written determination granting or denying the application in whole or in part. Prior to granting or denying a franchise under this Article, the City Council shall conduct a public hearing and make a decision based upon the following standards. If the application is denied, the written determination shall include the reason for denial.

A. The financial and technical ability of the applicant.

B. The legal ability of the applicant.

C. The capacity of the public ways to accommodate the applicant's proposed facilities.

D. The capacity of the public ways to accommodate additional utility and telecommunications facilities if the franchise is granted.

E. The damage or disruption, if any, of public or private facilities, improvements, service, travel or landscaping if the franchise is granted.

- F. The public interest in minimizing the cost and disruption of construction within the public ways.
- G. The service that applicant will provide to the community and region.
- H. The effect, if any, on public health, safety and welfare if the franchise requested is granted.
- I. The availability of alternate routes and/or locations for the proposed facilities.
- J. Applicable federal and state telecommunications laws, regulations and policies.
- K. Such other factors as may demonstrate that the grant to use the public ways will serve the community interest.
- L. That the requirements of RCW 35A.47.040 have been complied with.

**Section 12.18.0132: Agreement.** No franchise shall be deemed to have been granted hereunder until the applicant and the City have executed a written agreement setting forth the particular terms and provisions under which the franchisee has been granted to right to occupy and use public ways of the City.

**Section 12.18.0133: Nonexclusive Grant.** No franchise granted under this Article shall confer any exclusive right, privilege, license or franchise to occupy or use the public ways of the City for delivery of telecommunications services or any other purposes.

**Section 12.18.0134: Terms of Franchise Grant.** Unless otherwise specified in a franchise agreement, a telecommunications franchise granted hereunder shall be valid for a term of ten (10) years.

**Section 12.18.0135: Rights Granted.** No franchise granted under this Article shall convey any right, title or interest in the public ways, but shall be deemed a franchise only to use and occupy the public ways for the limited purposes and term stated in the grant. Further, no franchise shall be construed as any warranty of title.

**Section 12.18.0136: Franchise Territory.** A telecommunications franchise granted under this Article shall be limited to the specific geographic area of the City to be served by the franchisee, and the specific public ways necessary to serve such areas.

**Section 12.18.0137: Compensation to the City.** Each franchise granted under this Article is subject to the City's right, which is expressly reserved, to annually fix a fair and reasonable compensation to be paid for the franchise rights granted to the franchisee; provided, nothing in this Chapter shall prohibit the City and a franchisee from agreeing to the compensation to be paid.

**Section 12.18.0138: Nondiscrimination.** A franchisee shall make its telecommunications services available to any customer within its franchise area who shall request such service, without discrimination as to the terms, conditions, rates or charges for the franchisee's services; provided, however, that nothing in this Chapter shall prohibit a franchisee from making any reasonable classifications among differently situated customers.

**Section 12.18.0139: Amendment of Franchise Grant.** A new franchise application and grant shall be required of any telecommunications carrier that desires to extend its franchise territory or to locate its telecommunications facilities in public ways of the City which are not included in a franchise previously granted under this Article. If ordered by the City to locate or relocate its telecommunications facilities in public ways not included in a previously granted franchise, the City shall grant a franchise amendment without further application.

**Section 12.18.0140: Renewal Application.** A franchisee that desires to renew its franchise under this Chapter shall, not more than 180 days nor less than 120 days before expiration of the current franchise, file an application with the City for renewal of its franchise which shall include the following:

- A. The information required pursuant to Section 12.18.0300 of this Chapter.
- B. Any information required pursuant to the franchise agreement between the City and the grantee.
- C. All deposits or charges required pursuant to this Chapter.
- D. An application fee which shall be set by the City Council by resolution.

**Section 12.18.0141: Renewal Determination.** Within 120 days after receiving a complete application for renewal under Section 12.18.0400 hereof, the City shall issue a written determination granting or denying the renewal application in whole or in part. Prior to granting or denying renewal of a franchise under this Article, the City Council shall conduct a public hearing and make a decision based upon the following standards. If the renewal application is denied, the written determination shall include the reasons for non-renewal.

- A. The financial and technical ability of the applicant.
- B. The legal ability of the applicant.
- C. The continuing capacity of the public ways to accommodate the applicant's existing facilities.
- D. The applicant's compliance with the requirements of this Chapter and the franchise agreement.

E. Applicable federal, state and local telecommunications laws, rules and policies.

F. Such other factors as may demonstrate that the continued grant to use the public ways will serve the community interest.

**Section 12.18.0142: Obligation to Cure as a Condition of Renewal.** No franchise shall be renewed until any ongoing violations or defaults in the franchisee's performance of the franchise agreement, or of the requirements of this Chapter, have been cured, or a plan detailing the corrective action to be taken by the franchisee has been approved by the City.

## ARTICLE V. CABLE TELEVISION FRANCHISE

<b>Sections</b>	<b>12.18.430</b>	<b>Cable Television Franchise.</b>
	<b>12.18.440</b>	<b>Franchise Application.</b>
	<b>12.18.450</b>	<b>Determination by City.</b>
	<b>12.18.460</b>	<b>Agreement.</b>
	<b>12.18.470</b>	<b>Nonexclusive Grant.</b>
	<b>12.18.480</b>	<b>Terms of Franchise Grant.</b>
	<b>12.18.490</b>	<b>Rights Granted.</b>
	<b>12.18.500</b>	<b>Franchise Territory.</b>
	<b>12.18.510</b>	<b>Nondiscrimination.</b>
	<b>12.18.520</b>	<b>Amendment of Franchise Grant.</b>
	<b>12.18.530</b>	<b>Renewal Application.</b>
	<b>12.18.540</b>	<b>Renewal Determination.</b>
	<b>12.18.550</b>	<b>Obligation to Cure as Condition of Renewal.</b>
	<b>12.18.560</b>	<b>Rates.</b>
	<b>12.18.570</b>	<b>Franchise Fee.</b>
	<b>12.18.580</b>	<b>Periodic Meetings.</b>
	<b>12.18.590</b>	<b>Cable System Evaluation.</b>
	<b>12.18.600</b>	<b>Public, Educational and Governmental Access.</b>
	<b>12.18.610</b>	<b>City-wide Public, Educational and Governmental Access Interconnection.</b>
	<b>12.18.620</b>	<b>Institutional Networks (I-Nets).</b>
	<b>12.18.630</b>	<b>City-wide Institutional Networks Interconnection.</b>
	<b>12.18.640</b>	<b>Access and Institutional Network Equipment.</b>
	<b>12.18.650</b>	<b>External Franchising Costs.</b>
	<b>12.18.660</b>	<b>Continuity of Service.</b>
	<b>12.18.670</b>	<b>Equalization of Civic Contributions.</b>
	<b>12.18.680</b>	<b>Subscriber Rate Complaint Process.</b>
	<b>12.18.690</b>	<b>Parental Control Devices.</b>
	<b>12.18.700</b>	<b>Discounts.</b>
	<b>12.18.710</b>	<b>Customer Service.</b>
	<b>12.18.720</b>	<b>Telephone Response.</b>



12.18.730	<b>Failure to Improve Customer Service.</b>
12.18.740	<b>Reports.</b>
12.18.750	<b>Programming.</b>
12.18.760	<b>Inconsistency.</b>

**Section 12.18.0143: Cable Television Franchise.** A cable television franchise shall be required of any telecommunications carrier, cable operator, or other person who desires to occupy the public ways of the City and to provide cable service to any person or area in the City.

**Section 12.18.0144: Franchise Application.** Any person that desires a cable television franchise pursuant to this Article shall file an application with the City which, in addition to the materials required by Section 12.18.290, shall include information whether the applicant intends to provide telecommunications service, and sufficient information to determine whether such service is subject to telecommunications franchising pursuant to this Chapter.

**Section 12.18.0145: Determination by the City.** Within 120 days after receiving a complete application under Section 12.18.0440, the City shall issue a written determination granting or denying the application in whole or in part. Prior to granting or denying a franchise under this Article, the City Council shall conduct a public hearing and make a decision based upon the standards set forth in Section 12.18.310. If the application is denied, the written determination shall include the reason(s) for denial.

**Section 12.18.0146: Agreement.** No franchise shall be deemed to have been granted hereunder until the applicant and the City have executed a written agreement setting forth the particular terms and provisions under which the franchisee has been granted to right to occupy and use public ways of the City and to provide cable service to persons or areas within the City.

**Section 12.18.0147: Nonexclusive Grant.** No franchise granted under this Article shall confer any exclusive right, privilege, license or franchise to occupy or use the public ways of the City for delivery of cable services or any other purposes.

**Section 12.18.0148: Terms of Franchise Grant.** Unless otherwise specified in a franchise agreement, a cable franchise granted hereunder shall be valid for a term of ten (10) years.

**Section 12.18.0149: Rights Granted.** A cable television franchise granted pursuant to this Article shall authorize a franchisee:

A. To engage in the business of operating and providing cable service and services and the distribution and sale of such services to subscribers within the City; and

B. To erect, install, construct, repair, replace, reconstruct, maintain and retain in, on, over, under, upon, across and along any public way, such amplifiers and appliances, lines, cables, conductors, vaults, manholes, pedestals, attachments, supporting structures, and other property as may be necessary and appropriate to the cable system.

Provided, however, that no privilege or exemption shall be granted or conferred upon a franchisee by any franchise except as specifically prescribed therein, and any use of any public way shall be consistent with any prior lawful occupancy of the public way or any subsequent improvement or installation therein. Provided further, that no franchise granted pursuant to this Article shall convey any right, title or interest in the public ways, but shall be deemed a franchise only to use and occupy the public ways for the limited purposes and term stated in the grant. No franchise shall be construed as any warranty of title.

**Section 12.18.0150: Franchise Territory.** A cable television franchise granted under this Article shall be limited to the specific geographic area of the City to be served by the franchisee, and the specific public ways necessary to serve such areas.

**Section 12.18.0151: Nondiscrimination.** A franchisee shall make its telecommunications services available to any customer within its franchise area who shall request such service, without discrimination as to the terms, conditions, rates or charges for grantee's services; provided, however, that nothing in this Chapter shall prohibit a franchisee from making any reasonable classifications among differently situated customers. Provided further, that nothing in this Ordinance shall be deemed to prohibit the establishment of a graduated scale of charges and classified rate schedules to which any customer coming within such classification would be entitled, and that connection and/or service charges may be waived or modified during promotional campaigns of a franchisee. A franchisee will not deny access to cable service to any group of potential residential subscribers because of the income of the residents of the local area in which the group resides.

**Section 12.18.0152: Amendment of Franchise Grant.** Except as otherwise provided by 47 U.S.C. § 545, a new franchise application and grant shall be required of any cable operator that desires to extend its franchise territory, to locate its cable facilities in public ways of the City which are not included in a franchise previously granted under this Article, or to otherwise modify its franchise or franchise agreement. If ordered by the City to locate or relocate its cable facilities in public ways not included in a previously granted franchise, the City shall grant a franchise amendment without further application.

**Section 12.18.0153: Renewal Application.** A franchisee that desires to renew its franchise under this Chapter shall, not more than 180 days nor less than 120 days before expiration of the current franchise, file an application with the City for renewal of its franchise which shall include the following:

- A. The information required pursuant to Section 12.18.0440 of this Chapter.
- B. Any information required pursuant to the franchise agreement between the City and the grantee.
- C. Any information required pursuant to the Cable Act.
- D. All deposits or charges required pursuant to this Chapter.

E. An application fee which shall be set by the City Council by resolution.

**Section 12.18.0154: Renewal Determination.** Within 120 days after receiving a complete application under Section 12.18.530, the City shall issue a written determination granting or denying the renewal application in whole or in part. Prior to granting or denying renewal of a franchise under this Article, the City Council shall conduct a public hearing and make a decision based upon the standards set forth in the Cable Act, its implementing regulations, and the standards set forth in Section 12.18.410. If the renewal application is denied, the written determination shall include the reason(s) for non-renewal.

**Section 12.18.0155: Obligation to Cure as a Condition of Renewal.** No franchise shall be renewed until any ongoing violations or defaults in the franchisee's performance of the franchise agreement, or of the requirements of this Chapter, have been cured, or a plan detailing the corrective action to be taken by the franchisee has been approved by the City.

**Section 12.18.0156: Rates.** Within thirty (30) days after the grant of franchise pursuant to this Article, a franchisee shall file with the City a complete schedule of all present rates charged to all subscribers. Prior to implementation of any change in rates or charges for any service or equipment provided by a franchisee, a franchisee shall provide the City and all subscribers a minimum of thirty (30) days prior written notice of such change. Subject to 47 U.S.C. § 543 and applicable FCC regulations, the City may regulate the rates or charges for providing cable service and other equipment and may establish rate regulation review procedures as delegated by Federal law.

**Section 12.18.0157: Franchise Fee.** As permitted by 47 U.S.C. § 542, a franchisee shall pay the City a franchise fee equal to five percent (5%) or greater of its gross revenues as defined in this Chapter. The franchise fee shall be paid quarterly, on or before the thirtieth (30th) day of each January, April, July, and October. Such remittances shall be accompanied by forms furnished by the City to report reasonably detailed information as to the sources of such revenues.

**Section 12.18.0158: Periodic Meetings.** Upon request, but not more than once during any calendar year, a franchisee shall meet with designated City officials and/or designated representative(s) of the City to review the performance of a franchisee for the preceding period. The franchisee shall be given not less than thirty (30) days' prior written notice of any such meeting. The subjects may include, but are not limited to, those items covered in the periodic reports and performance tests.

**Section 12.18.0159: Cable System Evaluation.** In addition to periodic meetings, and with written notice of not less than five (5) business days so that a franchisee can arrange to have necessary personnel present, the City may require reasonable evaluation sessions at any time during the term of a franchise. It is intended that such evaluations cover areas such as customer service, response to the community's cable-related needs, and a franchisee's performance under and compliance with the terms of a franchise.

**Section 12.18.0160: Public, Educational and Governmental Access.** As permitted by 47 U.S.C. § 531, the City may require, as a condition of a franchise granted pursuant to this Article, provisions for Public, Educational and Government (PEG) Access.

**Section 12.18.0161: City-wide Public, Educational and Government Access Interconnection.** As permitted by 47 U.S.C. § 531, the City may request a franchisee to begin negotiations to interconnect PEG access channels of a cable television system with any and all other contiguous and compatible cable systems. Interconnection of system may be accomplished by direct cable connection, microwave link, or other technically feasible method. Upon receiving request of the City to interconnect, if a franchisee has not already done so, a franchisee shall initiate negotiations with other affected system(s), and shall report to the City the results of such negotiations no later than sixty (60) days after such initiation. Any costs of interconnection may be passed through to subscribers by a franchisee.

**Section 12.18.0162: Institutional Networks (I-Nets).** A franchisee's cable system shall have the capability of serving designated educational and public buildings with uni- or bi-directional video/audio signals. The linkage may be by cable, microwave or other means deemed appropriate by a franchisee. If required, suitable encoding and decoding devices shall be made available by a franchisee to assure transmission security. A public entity desiring the activation of such service shall make application thereof to a franchisee. Activation of such services to a public entity shall not be unduly denied. As provided by the Cable Act, a public entity in the City denied such service may request a public hearing to evaluate such denial. Both the requestor and the franchisee shall be provided the opportunity to present the reasons for the request and the reasons for the denial. Upon a finding by the City Council that these services are reasonably required to meet community needs, taking into account the cost of meeting such needs, the City Council may require the activation of such services for the public entity in a reasonable time and on the same basis that other public entities in the City receive the same service.

**Section 12.18.0163: City-wide Institutional Networks Interconnection.** A franchise agreement may require a franchisee to make such interconnections as necessary to connect certain designated institutions on a City-wide basis. The same conditions as enumerated in Section 12.18.0620 shall apply to such interconnections.

**Section 12.18.0164: Access and Institutional Network Equipment.** A franchise agreement may require a franchisee to contribute either specified goods and services and/or a specified sum of money for the purpose of providing facilities and equipment for PEG access programming and the Institutional Networks.

**Section 12.18.0165: External Franchising Costs.** Prior to expenditure of capital for any franchise related requirements that would be treated as an external cost passed through to customers, the franchisee shall notify the City of its intent to exercise its right and the amount to be passed through to customers. The City may waive the franchise related requirement if, in the City's opinion, the increase in rates would be a burden on City rate payers.

**Section 12.18.0166: Continuity of Service.** It shall be the right of all subscribers to continue receiving service so long as their financial and other obligations to a franchisee are fulfilled. In this regard a franchisee shall act so far as it is reasonably within its control to provide all subscribers with continuous uninterrupted service during the term of the franchise, subject to applicable law. In the event a franchisee fails to operate a system for seventy-two (72) continuous and consecutive hours without prior notification to and approval of the City Council or without just cause such as an impossibility to operate the system because of the occurrence of an act of God or other circumstances reasonably beyond a franchisee's control, the City may, after notice and an opportunity for a franchisee to commence operations at its option, operate the emergency alert system or designate someone to operate the emergency alert system until such time as a franchisee restores service or a replacement franchisee is selected. If the City is required to fulfill this obligation for a franchisee, a franchisee shall reimburse the City for all reasonable costs or damages that are the result of a franchisee's failure to perform.

**Section 12.18.0167: Equalization of Civic Contributions.** In the event of one or more new franchises being granted, the City may require that such subsequent franchisees pay to the City an amount proportionally equal to franchising costs contributed by the initial franchisee. These costs may include but are not limited to such features as access and institutional network costs, bi-directional or equivalent cable installed to municipal buildings and similar expenses. Additional franchisees shall provide all PEG access channel(s) currently available to the subscribers of existing franchisees. In order to provide these access channels, additional franchisees shall interconnect, at their cost, with existing franchisees, subject to any reasonable terms and conditions that the existing franchisee providing the interconnection may require. These interconnection agreements shall be made directly between the franchisees. The City Council, in such cases of dispute of award, may be called upon to arbitrate regarding these arrangements. Additional franchisees shall contribute towards costs of PEG access paid by a prior franchisee by paying to the prior franchisee on each anniversary of the grant of the subsequent franchise an amount equal to a proportionate share of the amount contributed by the prior franchisee for PEG access costs in constant dollars. This proportionate share shall be based upon the number of subscribers in the City held by each franchise and shall be contributed until such time as equal contributions towards the cost of PEG access have been made.

**Section 12.18.0168: Subscriber Rate Complaint Process.** As provided by 47 U.S.C. § 543, any subscriber aggrieved by a cable rate increase shall file its cable rate complaint with the City within ninety (90) days of the effective date of such an increase. Such complaints shall be submitted upon a form prescribed by the City Administrator. If the City receives cable rate complaints from cable subscribers, it may, in its sole discretion, file a cable rate complaint with the FCC, seeking review of any such rate increase.

**Section 12.18.0169: Parental Control Devices.** A franchisee shall make available at its cost, including applicable handling fees, a device by which the subscriber can prohibit viewing of a particular cable service during periods selected by that subscriber.

**Section 12.18.0170: Discounts.** A franchisee shall offer a discount of thirty percent (30%) from the normal charge for basic services and installation to those individuals age sixty-two (62) or

older or disabled who are the legal owner or lessee/tenant of their residence provided that their combined disposal income from all sources does not exceed the median income level Housing and Urban Development (HUD) standards for the Seattle-Everett area for the preceding calendar year. The City or its designee shall be responsible for certifying to a franchisee that such applicants conform to the specified criteria.

**Section 12.18.0171: Customer Service.**

**A.** A franchisee shall render repair service to restore the quality of the signal at approximately the same standards existing prior to the failure or damage of the component causing the failure and make repairs promptly and interrupt service only for good cause and for the shortest time possible. Such interruptions, insofar as possible, shall be preceded by notice and shall occur during a period of minimum use of the system. A log of all service interruptions shall be maintained for a period of at least one (1) year. The City, after two (2) working days' notice, may inspect such logs.

**B.** An employee of a franchisee shall answer and respond to all individual complaints received up until 5:00 p.m. weekdays. A franchisee may use an answering service to receive complaints after 5:00 p.m. weekdays and on weekends and holidays and shall respond to any system outage affecting more than five (5) subscribers regardless of day and hour. A copy of the instructions to the answering service by a franchisee shall be furnished to the City or its designee.

**C.** A technician shall be on call seven (7) days a week, twenty-four (24) hours a day. A franchisee shall respond immediately to service complaints in an efficient manner.

**D.** A franchisee shall maintain a sufficient repair force to respond to individual requests for repair service within two (2) working days after receipt of the complaint or request, except Saturday, Sunday and legal holidays. All complaints shall be resolved within seven (7) days, to the extent reasonable. If a subscriber has notified a franchisee of an outage, no charge for the period of the outage shall be made to the subscriber if the subscriber was without service for a period exceeding twenty-four (24) hours.

**E.** A franchisee shall supply at the time of a new connection, and periodically at least once a year, the title, address and telephone number of the city official or his/her designee, to whom subscribers may direct their concerns.

**F.** In no case will a franchisee's service standards fall below the standards established below the National Cable Television Association (NCTA) which are attached hereto as Appendix A, and incorporated by this reference as though completely set forth herein.

**Section 12.18.0172: Telephone Response.**

**A.** A franchisee shall maintain an adequate force of customer service representatives as well as incoming trunk lines so that telephone inquiries are met promptly and responsively. A franchisee shall have in place procedures for utilization of other manpower and/or

recording devices for handling the flow of telephone calls at peak periods of large outages or other major causes of subscriber concern. A copy of such procedures and/or policies shall be made available to the City.

**B.** In order that the City may be informed of a franchisee's success in achieving satisfactory customer relations in its telephone answering functions, a franchisee shall, upon request by the City, and routinely each quarter, provide the City with a summary that provides the following:

- (1) Total number of calls received in recording periods;
- (2) Time taken to answer;
- (3) Average talk time;
- (4) Number of calls abandoned by the caller;
- (5) Average hold time;
- (6) Percentage of time all lines busy;
- (7) An explanation of any abnormalities.

**C.** This data will be compared to the minimum standards of the NCTA, or any amendment thereto increasing such standards, and shall be monitored by the City.

**D.** Calls for service generated during periods of system outages due to emergencies affecting more than twenty-five (25) customers may be excluded from the service response calculations. The City shall have the sole determination as to what constitutes a system failure due to emergency and which calls shall be excluded from the service level calculations.

**Section 12.18.0173: Failure to Improve Customer Service.** The City or its designee shall review telephone response and customer service information with a franchisee. Improvements will be made by the franchisee in the appropriate categories which are found deficient from the last reporting period. Failure to do so may result in action being taken pursuant to Section 12.18.1050 of this Chapter.

**Section 12.18.0174: Reports.** A franchisee shall furnish, upon request, a report of its activities as appropriate. Such report shall include:

- A.** A copy of the franchisee's most recent annual report;
- B.** A copy of the franchisee's 10-K Report, if required by the Securities and Exchange Commission;
- C.** The number of homes passed by the franchisee's cable system;

- D. The number of subscribers with basic services;
- E. The number of subscribers with premium services;
- F. The number of hook-ups in the reporting period;
- G. The number of disconnects in the reporting period;
- H. The total number of miles of cable under the franchisee's control within the City;
- I. A summary of complaints received by category, length of time taken to resolve each complaint, and action taken to provide resolution;
- J. A copy of the franchisee's current billing practices, and a sample copy of the franchisee's current bill format;
- K. A copy of the franchisee's current subscriber service agreement;
- L. Any other such reports with respect to the franchisee's local operations, affairs, transactions, or property that the City may deem to be appropriate.

**Section 12.18.0175: Programming.** For informational purposes, a franchisee shall file a listing of its programming and the tiers in which they are placed. A franchisee shall consider the City's suggestions of general programming categories as determined from time to time in residential questionnaire polls. The results of such surveys, when performed, shall be appended to the respective franchise agreements.

**Section 12.18.0176: Inconsistency.** If any portion of this Article should be inconsistent or conflict with any rule or regulation now or hereafter adopted by the FCC or other Federal law, then to the extent of the inconsistency or conflict, the rule or regulation of the FCC or other Federal law shall control for so long, but only for so long, as such rule, regulation, or law shall remain in effect; provided the remaining provisions of this Article shall not be effected thereby.

## ARTICLE VI. CONDITIONS OF PERMITS AND FRANCHISES

<b>Sections</b>	<b>12.18.770</b>	<b>Purpose.</b>
	<b>12.18.780</b>	<b>Acceptance.</b>
	<b>12.18.790</b>	<b>Police Power.</b>
	<b>12.18.800</b>	<b>Rules and Regulations by City.</b>
	<b>12.18.810</b>	<b>Location of Facilities.</b>
	<b>12.18.820</b>	<b>Compliance with One Call Locator Service.</b>
	<b>12.18.830</b>	<b>Construction Permits.</b>
	<b>12.18.840</b>	<b>Interference with the Public Ways.</b>



12.18.850	Damage to Property.
12.18.860	Notice of Work.
12.18.870	Repair and Emergency Work.
12.18.880	Maintenance of Facilities.
12.18.890	Relocation or Removal of Facilities.
12.18.900	Building Moving.
12.18.910	Removal of Unauthorized Facilities.
12.18.920	Emergency Removal or Relocation of Facilities.
12.18.930	Damage to Facilities.
12.18.940	Restoration of Public Ways, Other Ways and City Property.
12.18.950	Facilities Maps.
12.18.960	Duty to Provide Information.
12.18.970	Leased Capacity.
12.18.980	Insurance.
12.18.990	General Indemnification.
12.18.1000	Performance and Construction Surety.
12.18.1010	Security Fund.
12.18.1020	Construction and Completion Bond.
12.18.1030	Coordination of Construction Activities.
12.18.1040	Assignments or Transfers of Grant.
12.18.1050	Transactions Affecting Control of Grant.
12.18.1060	Revocation or Termination of Grant.
12.18.1070	Notice and Duty to Cure.
12.18.1080	Hearing.
12.18.1090	Standards for Revocation or Lesser Sanctions.
12.18.1100	Incorporation by Reference.
12.18.1110	Notice of Entry on Private Property.
12.18.1120	Safety Requirements.

**Section 12.18.0177: Purpose.** The purpose of this Article is to set forth certain terms and conditions which are common to all Telecommunications Right-of-Way Use Permits, Telecommunications Franchises, and Cable Television Franchises. Except as otherwise provided in this Chapter or in such a permit or franchise, the provisions of this Article apply to all such permits and franchises approved or granted by the City Council.

**Section 12.18.0178: Acceptance.** No permit or franchise granted pursuant to the provisions of this Chapter shall become effective unless and until the ordinance granting the same has become effective. Within thirty (30) days after the effective date of the Ordinance granting a permit or awarding a franchise, or within such extended period of time as the Council in its discretion may authorize, a franchisee shall file with the City Administrator its written acceptance of the permit or franchise, in a form satisfactory to the City Attorney, together with the bonds, insurance policies, and security fund required by this Article.

**Section 12.18.0179: Police Power.** In accepting any permit or franchise, the permittee or franchisee acknowledges that its rights hereunder are subject to the legitimate rights of the police power of the City to adopt and enforce general ordinances necessary to protect the safety and welfare of the public and it agrees to comply with all applicable general laws enacted by the City pursuant to such power.

**Section 12.18.0180: Rules and Regulations by the City.** In addition to the inherent powers of the City to regulate and control any permit or franchise it issues, the authority granted to it by the Cable Act and the Telecommunications Act of 1996, and those powers expressly reserved by the City, or agreed to and provided for in any permit or franchise, the right and power is hereby reserved by the City to promulgate such additional regulations as it may find necessary in the exercise of its lawful powers giving due regard to the rights of permittee and franchisee's. Except as provided in this Chapter, the foregoing does not allow for amendment by the City of material terms of any permit or franchise it issues without the consent of the permittee or franchisee. The City Council reserves the right to delegate its authority for permit and franchise administration to a designated agent.

**Section 12.18.0181: Location of Facilities.** All facilities shall be constructed, installed and located in accordance with the following terms and conditions, unless otherwise specified in a permit or franchise agreement.

**A.** A permittee or franchisee grantee shall install its cable or telecommunications facilities within an existing underground duct or conduit whenever excess capacity exists within such utility facility.

**B.** A permittee or franchisee with permission to install overhead facilities shall install its cable or telecommunications facilities on pole attachments to existing utility poles only, and then only if surplus space is available.

**C.** Whenever any existing electric utilities, cable facilities or telecommunications facilities are located underground within a public way of the City, a permittee or franchisee with permission to occupy the same public way must also locate its cable or telecommunications facilities underground.

**D.** Whenever any new or existing electric utilities, cable facilities or telecommunications facilities are located or relocated underground within a public way of the City, a permittee or franchisee that currently occupies the same public way shall relocate its facilities underground. Absent extraordinary circumstances or undue hardship as determined by the City Public Works Director, such relocation shall be made concurrently to minimize the disruption of the public ways. No extension granted by the Director of Public Works under this Subsection shall exceed a period of twelve (12) months.

**E.** Whenever new cable or telecommunications facilities will exhaust the capacity of a public street or utility easement to reasonably accommodate future cable or telecommunications carriers or facilities, the permittee or franchisee and all other occupants of the

public way shall provide additional ducts, conduits, manholes and other facilities for nondiscriminatory access to future operators and carriers.

**Section 12.18.0182: Compliance with One Call Locator Service.** All permittees and franchisees shall, before commencing any construction in the public ways, comply with all regulations of Chapter 19.122 RCW, the One Call Locator Service.

**Section 12.18.0183: Construction Permits.** All permittees and franchisees are required to obtain construction permits for cable and telecommunications facilities as required in Article VII. of this Chapter. However, nothing in this Chapter shall prohibit the City and a permittee or franchisee from agreeing to alternative plan review, permit, and construction procedures for a permit or franchise agreement, provided such alternative procedures provide substantially equivalent safeguards for responsible construction practices.

**Section 12.18.0184: Interference with the Public Ways.** No permittee or franchisee may locate or maintain its cable or telecommunications facilities so as to unreasonably interfere with the use of the public ways by the City, by the general public or by other persons authorized to use or be present in or upon the public ways. All such facilities shall be moved by the permittee or franchisee, at the permittee or franchisee's cost, temporarily or permanently, as determined by the City Public Works Director.

**Section 12.18.0185: Damage to Property.** No permittee or franchisee nor any person acting on a permittee or franchisee's behalf shall take any action or permit any action to be done which may impair or damage any City property, public ways of the City, other ways or other property, whether publicly or privately owned, located in, on or adjacent thereto.

**Section 12.18.0186: Notice of Work.** Unless otherwise provided in a permit or franchise agreement, no permittee or franchisee, nor any person acting on the permittee's or franchisee's behalf, shall commence any non-emergency work in or about the public ways of the City or other ways without ten (10) working days' advance notice to the City.

**Section 12.18.0187: Repair and Emergency Work.** In the event of an unexpected repair or emergency, a permittee or franchisee may commence such repair and emergency response work as required under the circumstances, provided the permittee or franchisee shall notify the City as promptly as possible, before such repair or emergency work commences or as soon thereafter as possible if advance notice is not practicable.

**Section 12.18.0188: Maintenance of Facilities.** Each permittee or franchisee shall maintain its facilities in good and safe condition and in a manner that complies with all applicable federal, state and local requirements.

**Section 12.18.0189: Relocation or Removal of Facilities.** Within thirty (30) days following written notice from the City, a permittee or franchisee shall, at its own expense, temporarily or permanently remove, relocate, change or alter the position of any cable or

telecommunications facilities within the public ways whenever the City Public Works Director shall have determined that such removal, relocation, change or alteration is reasonably necessary for:

A. The construction, repair, maintenance or installation of any City or other public improvement in or upon the public ways.

B. The operations of the City or other governmental entity in or upon the public ways.

**Section 12.18.0190: Building Moving.** Whenever any person shall have obtained permission from the City to use any street or public way for the purpose of moving any building, a permittee or franchisee, upon seven (7) days' written notice from the City, shall raise or remove, at the expense of the person desiring to move the building, any of the permittee or franchisee's facilities which may obstruct the removal of such building; provided that the person desiring to move the building shall comply with all requirements of the City for the movement of buildings.

**Section 12.18.0191: Removal of Unauthorized Facilities.** Within thirty (30) days following written notice from the City, any permittee, telecommunications carrier, or other person that owns, controls or maintains any unauthorized cable or telecommunications system, facility or related appurtenances within the public ways of the City shall, at its own expense, remove such facilities or appurtenances from the public ways of the City. A cable or telecommunications system or facility is unauthorized and subject to removal in the following circumstances:

A. Upon expiration or termination of the permittee or franchisee's permit or franchise.

B. Upon abandonment of a facility within the public ways of the City. Any property of a permittee or franchisee shall be deemed abandoned if left in place ninety (90) days after expiration or termination of a permit or franchise.

C. If the system or facility was constructed or installed without the prior grant of a permit or franchise.

D. If the system or facility was constructed or installed without the prior issuance of a required construction permit.

E. If the system or facility was constructed or installed at a location not permitted by the permittee or franchisee's permit or franchise.

Provided, however, that the City may, in its sole discretion, allow a permittee, franchisee, or other such persons who may own, control, or maintain cable or telecommunications facilities within the public ways of the City to abandon such facilities in place. No facilities of any type may be abandoned in place without the express written consent of the City. Any plan for abandonment or removal of a permittee or franchisee's facilities must be first approved by the Public Works Director, and all necessary permits must be obtained prior to such work. Upon permanent abandonment of

the property of such persons in place, the property shall become that of the City, and such persons shall submit to the City Administrator an instrument in writing, to be approved by the City Attorney, transferring to the City the ownership of such property. The provisions of this Section shall survive the expiration, revocation, or termination of a permit or franchise granted under this Chapter.

**Section 12.18.0192: Emergency Removal or Relocation of Facilities.** The City retains the right and privilege to cut or move any cable telecommunications facilities located within the public ways of the City, as the City may determine to be necessary, appropriate or useful in response to any public health or safety emergency. The City shall not be liable to any cable operator, telecommunications carrier, or any other party for any direct, indirect, or any other such damages suffered by any person or entity of any type as a direct or indirect result of the City's actions under this Section.

**Section 12.18.0193: Damage to Facilities.** Unless directly and proximately caused by the willful, intentional or malicious acts by the City, the City shall not be liable for any damage to or loss of any cable or telecommunications facility upon City property or within the public ways of the City as a result of or in connection with any public works, public improvements, construction, excavation, grading, filling, or work of any kind on such City property or within the public ways by or on behalf of the City.

**Section 12.18.0194: Restoration of Public Ways, Other Ways and City Property.**

**A.** When a permittee or franchisee, or any person acting on its behalf, does any work in or affecting any public ways, other ways or City property, it shall, at its own expense, promptly remove any obstructions therefrom and restore such ways or property to as good a condition as existed before the work was undertaken, unless otherwise directed by the City.

**B.** If weather or other conditions do not permit the complete restoration required by this Section, the permittee or franchisee shall temporarily restore the affected ways or property. Such temporary restoration shall be at the permittee or franchisee's sole expense and the permittee or franchisee shall promptly undertake and complete the required permanent restoration when the weather or other conditions no longer prevent such permanent restoration.

**C.** A permittee, franchisee or other person acting in its behalf shall use suitable barricades, flags, flagmen, lights, flares and other measures as required for the safety of all members of the general public and to prevent injury or damage to any person, vehicle or property by reason of such work in or affecting such ways or property.

**Section 12.18.0195: Facilities Maps.** Each permittee or franchisee shall provide the City with an accurate map or maps certifying the location of all telecommunications facilities within the public ways. Each permittee or franchisee shall provide the City with updated maps annually.

**Section 12.18.0196: Duty to Provide Information.** Within ten (10) days of a written request from the City Administrator, each permittee or franchisee shall furnish the City with information sufficient to demonstrate:

A. That permittee or franchisee has complied with all requirements of this Chapter.

B. That all sales, utility and/or telecommunications taxes due the City in connection with the cable or telecommunications services and facilities provided by the permittee have been properly collected and paid by the permittee or franchisee.

C. All books, records, maps and other documents, maintained by the permittee or franchisee with respect to its facilities within the public ways shall be made available for inspection by the City at reasonable times and intervals.

Provided, however, that nothing in this section shall be construed to require a permittee or franchisee to violate state or federal law regarding subscriber privacy, nor shall this section be construed to require a permittee or franchisee to disclose proprietary or confidential information without adequate safeguards for its confidential or proprietary nature.

**Section 12.18.0197: Leased Capacity.** A permittee or franchisee shall have the right, without prior City approval, to offer or provide capacity or bandwidth to its customers consistent with such permit or franchise; provided:

A. The permittee or franchisee shall furnish the City with a copy of any such lease or agreement between the permittee or franchisee and the customer or lessee; and

B. The customer or lessee complied, to the extent applicable, with the requirements of this Chapter.

**Section 12.18.0198: Insurance.** Unless otherwise provided in a permit or franchise agreement, each permittee or franchisee shall, as a condition of the permit or grant, secure and maintain the following liability insurance policies insuring both the permittee or franchisee and the City, and its elected and appointed officers, officials, agents and employees as co-insureds:

A. Comprehensive general liability insurance with limits not less than

(1) Five Million Dollars (\$5,000,000) for bodily injury or death to each person;

(2) Five Million Dollars (\$5,000,000) for property damage resulting from any one accident; and

(3) Five Million Dollars (\$5,000,000) for all other types of liability.

B. Automobile liability for owned, non-owned and hired vehicles with a limit of Three Million Dollars (\$3,000,000) for each person and Three Million Dollars (\$3,000,000) for each accident.

C. Worker's compensation within statutory limits and employer's liability insurance with limits of not less than One Million Dollars (\$1,000,000).

D. Comprehensive form premises-operations, explosions and collapse hazard, underground hazard and products completed hazard with limits of not less than Three Million Dollars (\$3,000,000).

E. The liability insurance policies required by this section shall be maintained by the permittee or franchisee throughout the term of the permit or franchise, and such other period of time during which the permittee or franchisee is operating without a franchise or permit hereunder, or is engaged in the removal of its telecommunications facilities. Each such insurance policy shall contain the following endorsement:

It is hereby understood and agreed that this policy may not be cancelled nor the intention not to renew be stated until 90 days after receipt by the City, by registered mail, of a written notice addressed to the City Administrator of such intent to cancel or not to renew.

F. Within sixty (60) days after receipt by the City of said notice, and in no event later than thirty (30) days prior to said cancellation or intent not to renew, the permittee or franchisee shall obtain and furnish to the City replacement insurance policies meeting the requirements of this Section.

**Section 12.18.0199: General Indemnification.** No permit or franchise shall be deemed to be granted under this Chapter unless it includes an indemnity clause substantially conforming to the following:

The permittee or franchisee hereby releases, covenants not to bring suit and agrees to indemnify, defend and hold harmless the City, its officers, employees, agents and representatives from any and all claims, costs, judgments, awards or liability to any person, including claims by the permittee or franchisee's own employees to which the permittee or franchisee might otherwise be immune under Title 51 RCW, arising from injury or death of any person or damage to property of which the negligent acts or omissions of the permittee or franchisee, its agents, servants, officers or employees in performing under this permit or franchise are the proximate cause. The permittee or franchisee further releases, covenants not to bring suit and agrees to indemnify, defend and hold harmless the City, its officers and employees from any and all claims, costs, judgments, awards or liability to any person including claims by the permittee or franchisee's own employees, including those claims to which the permittee or franchisee might otherwise have immunity under Title 51 RCW, arising against the City solely by virtue of the City's ownership or control of the rights-of-way or other public properties, by virtue of the permittee or franchisee's exercise of the rights granted herein, or by virtue of the City's permitting the permittee or franchisee's use of the City's rights-of-way or other public property, based upon the City's inspection or lack of inspection of work performed by the permittee or

franchisee, its agents and servants, officers or employees in connection with work authorized on the City's property or property over which the City has control, pursuant to this permit or franchise or pursuant to any other permit or approval issued in connection with this permit or franchise. This covenant of indemnification shall include, but not be limited by this reference, claims against the City arising as a result of the negligent acts or omissions of the permittee or franchisee, its agents, servants, officers or employees in barricading, instituting trench safety systems or providing other adequate warnings of any excavation, construction, or work in any public right-of-way or other public place in performance of work or services permitted under this permit or franchise.

Inspection or acceptance by the City of any work performed by the permittee or franchisee at the time of completion of construction shall not be grounds for avoidance of any of these covenants of indemnification. Said indemnification obligations shall extend to claims which are not reduced to a suit and any claims which may be compromised prior to the culmination of any litigation or the institution of any litigation.

In the event that the permittee or franchisee refuses the tender of defense in any suit or any claim, said tender having been made pursuant to the indemnification clauses contained herein, and said refusal is subsequently determined by a court having jurisdiction (or such other tribunal that the parties shall agree to decide the matter), to have been a wrongful refusal on the part of the permittee or franchisee, then the permittee or franchisee shall pay all of the City's costs for defense of the action, including all reasonable expert witness fees and reasonable attorneys' fees and the reasonable costs of the City, including reasonable attorneys' fees of recovering under this indemnification clause.

In the event of liability for damages arising out of bodily injury to persons or damages to property caused by or resulting from the concurrent negligence of the permittee or franchisee and the City, its officers, employees and agents, the permittee or franchisee's liability hereunder shall be only to the extent of the permittee or franchisee's negligence. It is further specifically and expressly understood that the indemnification provided herein constitutes the permittee or franchisee's waiver of immunity under Title 51 RCW, solely for the purposes of this indemnification. This waiver has been mutually negotiated by the parties.

The provisions of this Section shall survive the expiration or termination of this franchise agreement.

Notwithstanding any other provisions of this Section, the permittee or franchisee assumes the risk of damage to its facilities located in the City's public ways, rights-of-way, and easements from activities conducted by the City, its officers, agents, employees and contractors. The permittee or franchisee releases and waives any and all claims against the City, its officers, agents, employees or contractors for damage



to or destruction of the permittee or franchisee's facilities caused by or arising out of activities conducted by the City, its officers, agents, employees and contractors, in the public ways, rights-of-way, and easements subject to this permit or franchise, except to the extent any such damage or destruction is caused by or arises from the sole negligence or any wilful or malicious action on the part of the City, its officers, agents, employees or contractors. The permittee or franchisee further agrees to indemnify, hold harmless and defend the City against any claims for damages, including, but not limited to, business interruption damages and lost profits, brought by or under users of the permittee or franchisee's facilities as the result of any interruption of service due to damage or destruction of the User's facilities caused by or arising out of activities conducted by the City, its officers, agents, employees or contractors, except to the extent any such damage or destruction is caused by or arises from the sole negligence or any wilful or malicious actions on the part of the City, its officers, agents, employees or contractors.

**Section 12.18.01100: Performance and Construction Surety.** Before a permit or franchise granted pursuant to this Chapter is effective, and as necessary thereafter, the permittee or franchisee shall provide and deposit such monies, bonds, letters of credit or other instruments in form and substance acceptable to the City as may be required by this Chapter or by an applicable permit or franchise agreement.

**Section 12.18.01101: Security Fund.** Each permittee or franchisee shall establish a permanent security fund with the City by depositing the amount of \$50,000 with the City in cash, an unconditional letter of credit, or other instrument acceptable to the City, which fund shall be maintained at the sole expense of the permittee or franchisee so long as any of the permittee or franchisee's cable or telecommunications facilities are located within the public ways of the City.

**A.** The fund shall serve as security for the full and complete performance of this Chapter, including any costs, expenses, damages or loss the City pays or incurs, including civil penalties, because of any failure attributable to the permittee or franchisee to comply with the codes, ordinances, rule, regulations or permits of the City.

**B.** Before any sums are withdrawn from the security fund, the City shall give written notice to the permittee or franchisee:

- (1) describing the act, default or failure to be remedied, or the damages, cost or expenses which the City has incurred by reason of permittee or franchisee's act or default;
- (2) providing a reasonable opportunity for permittee or franchisee to first remedy the existing or ongoing default or failure, if applicable;

- (3) providing a reasonable opportunity for permittee or franchisee to pay any monies due the City before the City withdraws the amount thereof from the security fund, if applicable;
- (4) that the permittee or franchisee will be given an opportunity to review the act, default or failure described in the notice with the City Administrator or his or her designee.

C. Grantees shall replenish the security fund within fourteen (14) days after written notice from the City that there is a deficiency in the amount of the fund.

**Section 12.18.01102: Construction and Completion Bond.** Unless otherwise provided in a permit or franchise agreement, a performance bond written by a corporate surety acceptable to the City equal to at least 100% of the estimated cost of constructing the permittee or franchisee's cable or telecommunications facilities within the public ways of the City shall be deposited before construction is commenced.

A. The construction bond shall remain in force until sixty (60) days after substantial completion of the work, as determined by the City Public Works Director, including restoration of public ways and other property affected by the construction.

B. The construction bond shall guarantee, to the satisfaction of the City:

- (1) timely completion of construction;
- (2) construction in compliance with applicable plans, permits, technical codes and standards;
- (3) proper location of the facilities as specified by the City;
- (4) restoration of the public ways and other property affected by the construction;
- (5) the submission of 'as-built' drawings after completion of the work as required by this Chapter.
- (6) timely payment and satisfaction of all claims, demands or liens for labor, material or services provided in connection with the work.

**Section 12.18.01103: Coordination of Construction Activities.** Section 12.18.090 notwithstanding, all permittees and franchisees are required to cooperate with the City and with each other.

A. By February 1 of each year, permittees and franchisees shall provide the City with a schedule of their proposed construction activities in, around, or that may affect the public ways.

B. Each permittee and franchisee shall meet with the City, other permittees and franchisees and users of the public ways annually or as determined by the City to schedule and coordinate construction in the public ways.

C. All construction locations, activities and schedules shall be coordinated, as ordered by the City Public Works Director, to minimize public inconvenience, disruption or damages.

**Section 12.18.01104: Assignments or Transfers of Grant.** Ownership or control of a cable or telecommunications system, license, permit, or franchise may not, directly or indirectly, be transferred, assigned or disposed of by sale, lease, merger, consolidation or other act of the grantee, by operation of law or otherwise, without the prior written consent of the City, which consent shall not be unreasonably withheld or delayed, except as expressed by ordinance and then only on such reasonable conditions as may be prescribed therein.

A. No permit, franchise, or other grant shall be assigned or transferred in any manner within twelve (12) months after the initial grant of the permit or franchise, unless otherwise provided in the permit or franchise agreement.

B. Absent extraordinary and unforeseeable circumstances, no grant, system or integral part of a system shall be assigned or transferred before construction of the telecommunications system has been completed.

C. The permittee or franchisee and the proposed assignee or transferee of the grant or system shall provide and certify the following information to the City not less than one hundred and fifty (150) days prior to the proposed date of transfer:

- (1) Complete information setting forth the nature, terms and condition of the proposed transfer or assignment;
- (2) All information required of a permit or franchise applicant pursuant to Articles III., IV. and V. of this Chapter with respect to the proposed transferee or assignee;
- (3) Any other information reasonably required by the City.
- (4) An application fee which shall be set by the City Council by resolution.

**D.** No transfer shall be approved unless the assignee or transferee has the legal, technical, financial and other requisite qualifications to own, hold and operate the cable or telecommunications system pursuant to this Chapter.

**E.** Unless otherwise provided in a license or franchise agreement, the permittee or franchisee shall reimburse the City for all direct and indirect costs and expenses reasonably incurred by the City in considering a request to transfer or assign a permit or franchise. No approval shall be deemed approved until all such costs and expenses have been paid.

**F.** Any transfer or assignment of a permit, franchise, system or integral part of a system without prior written approval of the City under this Section or pursuant to a permit or franchise agreement shall be void and is cause for revocation of the grant.

**Section 12.18.01105: Transactions Affecting Control of Grant.** Any transactions which singularly or collectively result in a change of fifty percent (50%) or more of the ownership or working control of the permittee or franchisee, of the ownership or working control of a cable or telecommunications system, of the ownership or working control of affiliated entities having ownership or working control of the permittee or franchisee or of a telecommunications system, or of control of the capacity or bandwidth of the permittee or franchisee's cable or telecommunication system, facilities or substantial parts thereof, shall be considered an assignment or transfer requiring City approval pursuant to Section 12.18.01040 hereof. Transactions between affiliated entities are not exempt from City approval. A franchisee shall promptly notify the City prior to any proposed change in, or transfer of, or acquisition by any other party of control of a franchisee's company. Every change, transfer, or acquisition of control of a franchisee's company shall cause a review of the proposed transfer. In the event that the City adopts a resolution denying its consent and such change, transfer or acquisition of control has been effected, the City may cancel the franchise. Approval shall not be required for mortgaging purposes or if said transfer is from a franchisee to another person or entity controlling, controlled by, or under common control with a franchisee.

**Section 12.18.01106: Revocation or Termination of Grant.** A permit or franchise granted by the City to use or occupy public ways of the City may be revoked for the following reasons:

**A.** Construction or operation in the City or in the public ways of the City without a permit or franchise grant of authorization.

**B.** Construction or operation at an unauthorized location.

**C.** Unauthorized substantial transfer of control of permittee or franchisee.

**D.** Unauthorized assignment of a permit or franchise.

**E.** Unauthorized sale, assignment or transfer of a permittee or franchisee's franchise, permit, assets, or a substantial interest therein.

F. Misrepresentation or lack of candor by or on behalf of a permittee or franchisee in any application or written or oral statement upon which the City relies in making the decision to grant, review or amend any permit or franchise pursuant to this Chapter.

G. Abandonment of cable or telecommunications facilities in the public ways.

H. Failure to relocate or remove facilities as required in this Chapter.

I. Failure to pay taxes, compensation, fees or costs when and as due the City.

J. Insolvency or bankruptcy of the permittee or franchisee.

K. Violation of any material provision of this Chapter.

L. Violation of the material terms of a permit or franchise agreement.

**Section 12.18.01107: Notice and Duty to Cure.** In the event that the City Administrator believes that grounds exist for revocation of a permit or franchise, he or she shall give the permittee or franchisee written notice of the apparent violation or noncompliance, providing a short and concise statement of the nature and general facts of the violation or noncompliance, and providing the permittee or franchisee a reasonable period of time not exceeding thirty (30) days to furnish evidence:

A. That corrective action has been, or is being actively and expeditiously pursued, to remedy the violation or noncompliance.

B. That rebuts the alleged violation or noncompliance.

C. That it would be in the public interest to impose some penalty or sanction less than revocation.

**Section 12.18.01108: Hearing.** In the event that a permittee or franchisee fails to provide evidence reasonably satisfactory to the City Administrator as provided in Section 12.18.1070 hereof, the City Administrator shall refer the apparent violation or non-compliance to the City Council. The City Council shall provide the permittee or franchisee with notice and a reasonable opportunity to be heard concerning the matter.

**Section 12.18.01109: Standards for Revocation or Lesser Sanctions.** If the City Council determines that a permittee or franchisee willfully violated or failed to comply with any of the provisions of this Chapter or a permit or franchise granted under this Chapter, or through willful misconduct or gross negligence failed to heed or comply with any notice given the permittee or franchisee by the City under the provisions of this Chapter, then the permittee or franchisee shall, at the election of the City Council, forfeit all rights conferred hereunder and the permit or franchise may be revoked or annulled by the City Council. The City Council may elect, in lieu of the above and without any prejudice to any of its other legal rights and remedies, to pursue other remedies,

including obtaining an order from the superior court having jurisdiction compelling the permittee or franchisee to comply with the provisions of this Chapter and any permit or franchise granted hereunder, and to recover damages and costs incurred by the City by reason of the permittee or franchisee's failure to comply. The City Council shall utilize the following factors in analyzing the nature, circumstances, extent and gravity of the violation and in making its determination under this Section:

- A. Whether the misconduct was egregious.
- B. Whether substantial harm resulted.
- C. Whether the violation was intentional.
- D. Whether there is a history of prior violations of the same or other requirements.
- E. Whether there is a history of overall compliance.
- F. Whether the violation was voluntarily disclosed, admitted or cured.

**Section 12.18.01110: Incorporation By Reference.** The provisions of this Chapter shall be incorporated by reference in any permit or franchise approved hereunder. The provisions of any proposal submitted and accepted by the City shall be incorporated by reference in the applicable permit or franchise. However, in the event of any conflict between the proposal, this Chapter, and the permit or franchise, the permit or franchise shall be the prevailing document.

**Section 12.18.01111: Notice of Entry on Private Property.** At least twenty-four (24) hours prior to entering private property or streets or public easements adjacent to or on such private property to perform new construction or reconstruction, a notice indicating the nature and location of the work to be performed shall be physically posted upon the affected property by the permittee or franchisee. A door hanger may be used to comply with the notice and posting requirements of this Section. A franchisee shall make a good faith effort to comply with the property owner/resident's preferences, if any, on location or placement of underground installations (excluding aerial cable lines utilizing existing poles and existing cable paths), consistent with sound engineering practices.

**Section 12.18.01112: Safety Requirements.** A permittee or franchisee, in accordance with applicable National, State, and Local safety requirements shall, at all times, employ ordinary care and shall install and maintain and use commonly accepted methods and devices for preventing failures and accidents which are likely to cause damage, injury, or nuisance to the public. All structures and all lines, equipment and connections in, over, under, and upon the streets, sidewalks, alleys, and public ways or places of a permit or franchise area, wherever situated or located, shall at all times be kept and maintained in a safe, suitable condition, and in good order and repair. The City reserves the general right to see that the system of a permittee or franchisee is constructed and maintained in a safe condition. If a violation of the National Electrical Safety Code or other applicable regulation is found to exist by the City, the City will, after discussions with a permittee

or franchisee, establish a reasonable time for a franchisee to make necessary repairs. If the repairs are not made within the established time frame, the City may make the repairs itself or have them made and collect all reasonable costs thereof from a permittee or franchisee.

## VII. CONSTRUCTION STANDARDS

Sections	12.18.1130	General Construction Standards.
	12.18.1140	Construction Codes.
	12.18.1150	Construction Permits.
	12.18.1160	Applications.
	12.18.1170	Engineer's Certification.
	12.18.1180	Traffic Control Plan.
	12.18.1190	Issuance of Permit.
	12.18.1200	Construction Schedule.
	12.18.1210	Compliance with Permit.
	12.18.1220	Display of Permit.
	12.18.1230	Survey of Underground Facilities.
	12.18.1240	Noncomplying Work.
	12.18.1250	Completion of Construction.
	12.18.1260	As-Built Drawings.
	12.18.1270	Restoration of Improvements.
	12.18.1280	Landscape Restoration.
	12.18.1290	Construction Surety.
	12.18.1300	Exceptions.
	12.18.1310	Responsibilities of the Owner.

**Section 12.18.01113: General Construction Standards.** No person shall commence or continue with the construction, installation or operation of cable or telecommunications facilities within the City except as provided in this Chapter.

**Section 12.18.01114: Construction Codes.** Cable and telecommunications facilities shall be constructed, installed, operated and maintained in accordance with all applicable federal, state and local codes, rules and regulations.

**Section 12.18.01115: Construction Permits.** No person shall construct or install any cable or telecommunications facilities within the City without first obtaining a construction permit therefor, provided, however:

A. No permit shall be issued for the construction or installation of cable or telecommunications facilities within the City unless the cable operator or telecommunications carrier has filed an application for a business license with the City pursuant to Article II of this Chapter.

B. No permit shall be issued for the construction or installation of telecommunications facilities in the public ways unless the cable operator or telecommunications carrier has applied for and received a permit or franchise pursuant to this Chapter.

C. No permit shall be issued for the construction or installation of cable or telecommunications facilities without payment of the construction permit fee established by a resolution adopted by the City Council for this purpose.

**Section 12.18.01116: Applications.** Applications for permits to construct cable or telecommunications facilities shall be submitted upon forms to be provided by the City and shall be accompanied by drawings, plans and specifications in sufficient detail to demonstrate:

A. That the facilities will be constructed in accordance with all applicable codes, rules and regulations.

B. The location and route of all facilities to be installed on existing utility poles.

C. The location and route of all facilities to be located under the surface of the ground, including the line and grade proposed for the burial at all points along the route which are within the public ways.

D. The location of all existing underground utilities, conduits, ducts, pipes, mains and installations which are within the public ways along the underground route proposed by the applicant.

E. The location of all other facilities to be constructed within the City, but not within the public ways.

F. The construction methods to be employed for protection of existing structures, fixtures, and facilities within or adjacent to the public ways.

G. The location, dimension and types of all trees within or adjacent to the public ways along the route proposed by the applicant, together with a landscape plan for protecting, trimming, removing, replacing and restoring any trees or areas to be disturbed during construction.

**Section 12.18.01117: Engineer's Certification.** All permit applications shall be accompanied by the certification of a registered professional engineer that the drawings, plans and specifications submitted with the application comply with applicable technical codes, rules and regulations.

**Section 12.18.01118: Traffic Control Plan.** All permit applications which involve work on, in, under, across or along any public ways shall be accompanied by a traffic control plan demonstrating the protective measures and devices that will be employed, consistent with Uniform Manual of Traffic Control Devices, to prevent injury or damage to persons or property and to minimize disruptions to efficient pedestrian and vehicular traffic.

**Section 12.18.01119: Issuance of Permit.** Within forty-five (45) days after submission of all plans and documents required of the applicant and payment of the permit fees required by this



Article, the City's Public Works Director, if satisfied that the applications, plans and documents comply with all requirements of this Chapter, shall issue a permit authorizing construction of the facilities, subject to such further conditions, restrictions or regulations affecting the time, place and manner of performing the work as he may deem necessary or appropriate.

**Section 12.18.01120: Construction Schedule.** The permittee shall submit a written construction schedule to the City Public Works Director ten (10) working days before commencing any work in or about the public ways. The permittee shall further notify the City Public Works Director not less than two (2) working days in advance of any excavation or work in the public ways.

**Section 12.18.01121: Compliance with Permit.** All construction practices and activities shall be in accordance with the permit and approved final plans and specifications for the facilities. The City Public Works Director and his or her representatives shall be provided access to the work and such further information as he or she may require to ensure compliance with such requirements.

**Section 12.18.01122: Display of Permit.** The permittee shall maintain a copy of the construction permit and approved plans at the construction site, which shall be displayed and made available for inspection by the City Public Works Director or his or her representatives at all times when construction work is occurring.

**Section 12.18.01123: Survey of Underground Facilities.** If the construction permit specifies the location of facilities by depth, line, grade, proximity to other facilities or other standard, the permittee shall cause the location of such facilities to be verified by a state-registered land surveyor. The permittee shall relocate any facilities which are not located in compliance with permit requirements.

**Section 12.18.01124: Noncomplying Work.** Upon order of the City Public Works Director, all work which does not comply with the permit, the approved plans and specifications for the work, or the requirements of this Chapter, shall be removed.

**Section 12.18.01125: Completion of Construction.** The permittee shall promptly complete all construction activities so as to minimize disruption of the public and other ways and other public and private property. All construction work authorized by a permit within public and other ways, including restoration, must be completed within one hundred twenty (120) days of the date of issuance.

**Section 12.18.01126: As-Built Drawings.** Within sixty (60) days after completion of construction, the permittee shall furnish the City with two (2) complete sets of plans, drawn to scale and certified to the City as accurately depicting the location of all cable or telecommunications facilities constructed pursuant to the permit.

**Section 12.18.01127: Restoration of Improvements.** Upon completion of any construction work, the permittee shall promptly repair any and all public and private property improvements, fixtures, structures and facilities in the public or other ways or otherwise damaged during the course

of construction, restoring the same as nearly as practicable to its condition before the start of construction.

**Section 12.18.01128: Landscape Restoration.**

A. All trees, landscaping and grounds removed, damaged or disturbed as a result of the construction, installation maintenance, repair or replacement of cable or telecommunications facilities, whether such work is done pursuant to a franchise or permit shall be replaced or restored as nearly as may be practicable, to the condition existing prior to performance of work.

B. All restoration work within the public ways shall be done in accordance with landscape plans approved by the City Public Works Director.

**Section 12.18.01129: Construction Surety.** Prior to issuance of a construction permit, the permittee shall provide a performance bond, as provided in Section 12.18.1020 of this Chapter.

**Section 12.18.01130: Exceptions.** Unless otherwise provided in a permit or franchise agreement, all cable operations and telecommunications carriers are subject to the requirements of this Article.

**Section 12.18.01131: Responsibilities of the Owner.** The owner of the facilities to be constructed and, if different, the permittee or franchisee, are responsible for performance of and compliance with all provisions of this Article.

**Section 2. Severability.** If any section, subsection, sentence, clause, phrase, or other portion of this Chapter, or its application to any person, is, for any reason, declared invalid, in whole or in part by any court or agency of competent jurisdiction, said decision shall not affect the validity of the remaining portions hereof.

Section 4. Effective date. This ordinance, being an exercise of a power specifically delegated to the City legislative body, is not subject to referendum. This ordinance shall take effect five (5) days after passage of publication of an approved summary thereof consisting of the title.

PASSED and ADOPTED by the Gig Harbor City Council this \_\_\_ day of \_\_\_\_\_, 1997.

CITY OF GIG HARBOR

\_\_\_\_\_  
GRETCHEN WILBERT, MAYOR

ATTEST/AUTHENTICATED:

By: \_\_\_\_\_  
Molly Towslee, City Clerk

APPROVED AS TO FORM:  
OFFICE OF THE CITY ATTORNEY:

By: \_\_\_\_\_  
Carol A. Morris, City Attorney

FILED WITH THE CITY CLERK: 10/8/97  
PASSED BY THE CITY COUNCIL:  
PUBLISHED:  
EFFECTIVE DATE:  
ORDINANCE NO. \_\_\_\_\_

**SUMMARY OF ORDINANCE NO. \_\_\_\_\_**

of the City of \_\_\_\_\_, Washington

---

On the \_\_\_ day of \_\_\_\_\_, 199\_, the City Council of the City of \_\_\_\_\_, passed Ordinance No. \_\_\_\_\_. A summary of the content of said ordinance, consisting of the title, provides as follows:

AN ORDINANCE OF THE CITY OF GIG HARBOR, WASHINGTON, RELATING TO TELECOMMUNICATIONS AND CABLE TELEVISION; ESTABLISHING REQUIREMENTS FOR TELECOMMUNICATION CARRIERS' AND CABLE OPERATORS' USE OF THE PUBLIC RIGHTS-OF-WAY AND PUBLIC PROPERTY; DESCRIBING THE PROCEDURES FOR APPLICATION AND APPROVAL OF TELECOMMUNICATION BUSINESS LICENSES, TELECOMMUNICATIONS RIGHT-OF-WAY USE PERMITS, FRANCHISES AND CABLE TELEVISION FRANCHISES; DESCRIBING VIOLATIONS AND ESTABLISHING PENALTIES; AND ADDING A NEW CHAPTER 12.18 TO THE GIG HARBOR MUNICIPAL CODE.

The full text of this Ordinance will be mailed upon request.

DATED this \_\_\_\_\_ day of \_\_\_\_\_, 199\_.

---

Molly Towslee, City Clerk



City of Gig Harbor. The "Maritime City."

3105 JUDSON STREET  
GIG HARBOR, WASHINGTON 98335  
(253) 851-8136

**TO: MAYOR WILBERT AND CITY COUNCIL MEMBERS**  
**FROM: MARK HOPPEN, CITY ADMINISTRATOR** *MH*  
**SUBJECT: TALMO STREET VACATION REQUEST**  
**DATE: SEPTEMBER 29, 1997**

#### **INTRODUCTION/BACKGROUND**

Talmo, Inc. proposes to build a bowling center and related facilities immediately south of the Wollochet Interchange, including portions of Wollochet Drive and 38th Avenue NW through vacation. Parcel "A" on Wollochet Drive and Parcels "B", "C", and "D" on 38th Avenue Northwest (see attached map) are proposed for vacation. Parcels "A" and "B" are to be vacated to Talmo, Inc., James O. Tallman, President. Parcels "C" and "D" are to be vacated to Burton Park Associates, David R. Morris, Managing Partner. Burton Park Associates will transfer Parcels "C", "D", and "E" through private arrangement to Talmo, Inc. in order to enable the private development and public roadway improvements associated with the development of the bowling center. Talmo, Inc. will be required to dedicate Parcel "E" for the purposes of public right-of-way improvements.

#### **POLICY CONSIDERATIONS**

The proposed vacations are consistent with the future right-of-way interests of the City of Gig Harbor and Washington state.

#### **PLANNING DEPARTMENT CONSIDERATIONS**

The Planning/Building Department indicates that three code provisions affecting the project necessitate enlarging the site through acquisition of easement. (1) The concomitant zoning agreement for the Tallman Annexation stipulates that impervious coverage shall not exceed 60%. The initial plan reviewed by City staff indicated approximately 75% impervious coverage. Coverage requirements could be met if the requested right-of-way were conveyed to the site. (2) The Design Manual requires screening and buffering along parcels abutting SR-16. Without the requested right-of-way, buffering would be difficult without significantly reducing the scale of the project. (3) The proposed bowling alley is part of a larger project which will include retail space. The combined uses will require a significant number of parking stalls. It would be difficult to provide the required parking and also conform to current setback standards without conveyance of the requested right-of-way.

As explained by the applicant, a bowling alley must be built upon undisturbed earth to avoid lane settling. Fill has been placed over portions of the site and final grading will require additional fill. This forces the building to the location indicated on the submitted site plan. *The previous requirements, (1), (2), and (3), can therefore not be met by any major adjustments in the building location, or without significantly reducing the scale of the project.*

## **PUBLIC WORKS CONSIDERATIONS**

After reviewing the proposed development with both Talmo, Inc. and the Washington State Department of Transportation (WSDOT), and after reviewing the City's Transportation Plan, the Public Works Director has determined that the right-of-way proposed for vacation is surplus to the City's needs.

WSDOT has confirmed that connection of the 38th Avenue right-of-way to the SR-16 right-of-way is not essential to future state plans for improvements to the SR-16 corridor. However, a business located within the SR-16 right-of-way north of 38th Avenue, south of Wollochet Drive, and east of the Talmo properties, has a lease with WSDOT, and has access along the western edge of the SR-16 right-of-way from the eastern terminus of 38th Avenue. This access will need to be maintained until such time as the lease expires, WSDOT needs the area for SR-16 improvements, and/or other arrangements are made for this business. The access rights of this business will need to be recognized in any right-of-way vacation.

WSDOT has also confirmed that their plans for improvements to the Wollochet Drive/SR-16 interchange will not be affected by the proposed vacation of a portion of the Wollochet Drive right-of-way. WSDOT's primary concern is that adequate provisions be in place to restrict drainage onto the SR-16 right-of-way, and further, not to restrict drainage from the SR-16 right-of-way.

The calculation of area along Wollochet Drive which would be surplus to the City's needs is based upon a five-lane section with bike lane, 4.5-ft. wide planter strip and 5.5-ft. wide sidewalk. This calculation resulted in a 45-ft. wide improved street section plus side slopes. The current site plan appears to have eliminated any need for a retaining wall at the base of the slope. However, at such time as improvements are constructed on Wollochet Drive, a construction easement may be necessary to complete the improvements. *The street vacations for Parcel "A" should reflect the need for the proponent to construct and maintain sufficient storm drainage through Talmo, Inc. property to prevent damage to WSDOT and city rights-of-way, and to reserve a construction easement for Wollochet Drive improvements.*

## **FISCAL CONSIDERATIONS**

The \$150 fee for processing this application as required by GHMC 12.14.004 has been paid. Additionally, if the City Council approves the vacation petition, \$500 will be deposited for the estimated cost of vacation property appraisal. If the appraisal cost is less than the amount deposited, then the vacation compensation shall be reduced by the difference between the deposit and the actual cost. If the cost of appraisal is more than the amount deposited, the vacation compensation payable to the city will be increased by the difference between the deposit and the actual cost.

The property proposed for vacation was not acquired at public expense. Therefore, a sum equal to one-half the fair market value, as shown in the appraisal, must be paid to the city prior to the passage of a vacation ordinance, which will occur after the required public hearing on the vacation.

**RECOMMENDATION**

Staff recommends that the City Council fix a time when the petition for vacation will be heard and determined that is not more than 60 days nor less than 20 days after the passage of the attached resolution. The resolution is presented for approval.

**CITY OF GIG HARBOR**

**RESOLUTION NO. \_\_\_\_\_**

**A RESOLUTION OF THE CITY COUNCIL OF THE CITY OF GIG HARBOR, WASHINGTON, ESTABLISHING NOVEMBER 10, 1997 AS THE DATE FOR A PUBLIC HEARING TO CONSIDER THE VACATION OF A PORTION OF WOLLOCHET DRIVE NORTHWEST AND 38<sup>TH</sup> AVE NW.**

---

WHEREAS, the City has received a petition signed by the owners of more than two-thirds (2/3) of the property abutting upon a portion of Wollochet Drive Northwest, lying south and west of State Route-16, and along the northwesterly frontage of Pierce County Short Plat No. 80-211; and all of that portion of 38<sup>th</sup> Avenue Northwest lying south of State Route 16, and generally north of the south line of Pierce County Short Plat No. 80-211, requesting that said right-of-way be vacated, and

WHEREAS, the City Council has considered the petition and has determined to hold a public hearing on the same, as provided in RCW 35.79.010 and Section 12.14.008 of the Gig Harbor Municipal Code; NOW, THEREFORE,

THE CITY COUNCIL OF THE CITY OF GIG HARBOR, WASHINGTON, HEREBY RESOLVES AS FOLLOWS:

Section 1. Hearing Set. Pursuant to RCW 35.79.010 and Section 12.14.008 of the Gig Harbor Municipal Code, the date and time of November 10, 1997 at 7:00 p.m., or soon thereafter as the matter may be heard, is hereby established as the date on which the Gig Harbor City Council will hold a public hearing to consider the vacation of certain right-of-way commonly known as a portion of Wollochet Drive Northwest, lying south and west of State Route-16, and along the northwesterly frontage of Pierce County Short Plat No. 80-211; and all of that portion of 38<sup>th</sup> Avenue Northwest



lying south of State Route 16, and generally north of the south line of Pierce County Short Plat No. 80-211, as depicted on the map attached hereto as Map 'A' and Map 'B', and incorporated herein by this reference as if set forth in full. The hearing will be held in the Gig Harbor City Council chambers at 3105 Judson Street, Gig Harbor, Washington 98335.

Section 2. Notice. The City Clerk is hereby directed to post written notice of the hearing in three (3) of the most public places in the City and a like notice in a conspicuous place on the right-of-way proposed to be vacated, as required by RCW 35.79.020 and Section 12.14.008 of the Gig Harbor Municipal Code. The notice shall be posted at least twenty (20) days in advance of the hearing.

RESOLVED this \_\_\_\_\_ day of \_\_\_\_\_, 1997.

APPROVED:

\_\_\_\_\_  
Gretchen A. Wilbert, Mayor

ATTEST / AUTHENTICATED:

\_\_\_\_\_  
Molly M. Towslee, City Clerk

Filed with the City Administrator: 10/1/97  
Passed by the City Council:  
Resolution No.

IMPORTANT- This is not a copy of Survey. It is furnished as a convenience to locate the land indicated herein with reference to streets and other land. No liability is assumed by reason of reliance hereon.

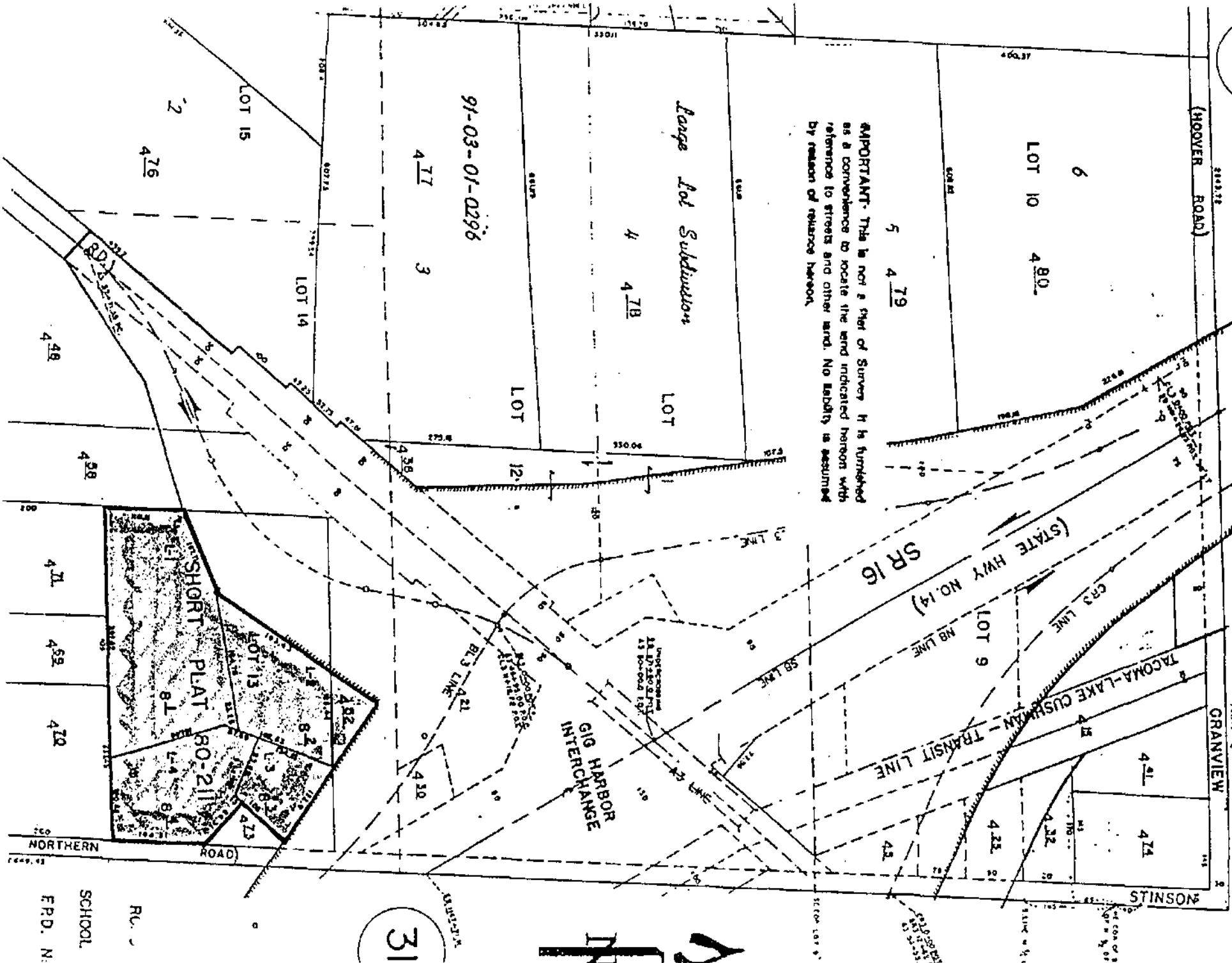

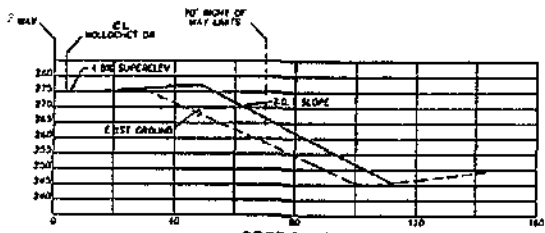

SECTION A-A  
SCALE: H - 1" = 20"  
V - 1" = 20"

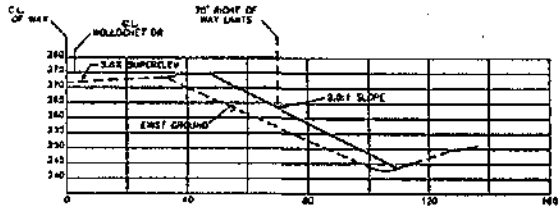

SECTION C-C  
SCALE: H - 1" = 20"  
V - 1" = 20"

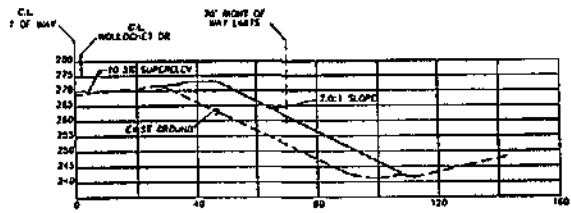

SECTION B-B  
SCALE: H - 1" = 20"  
V - 1" = 20"

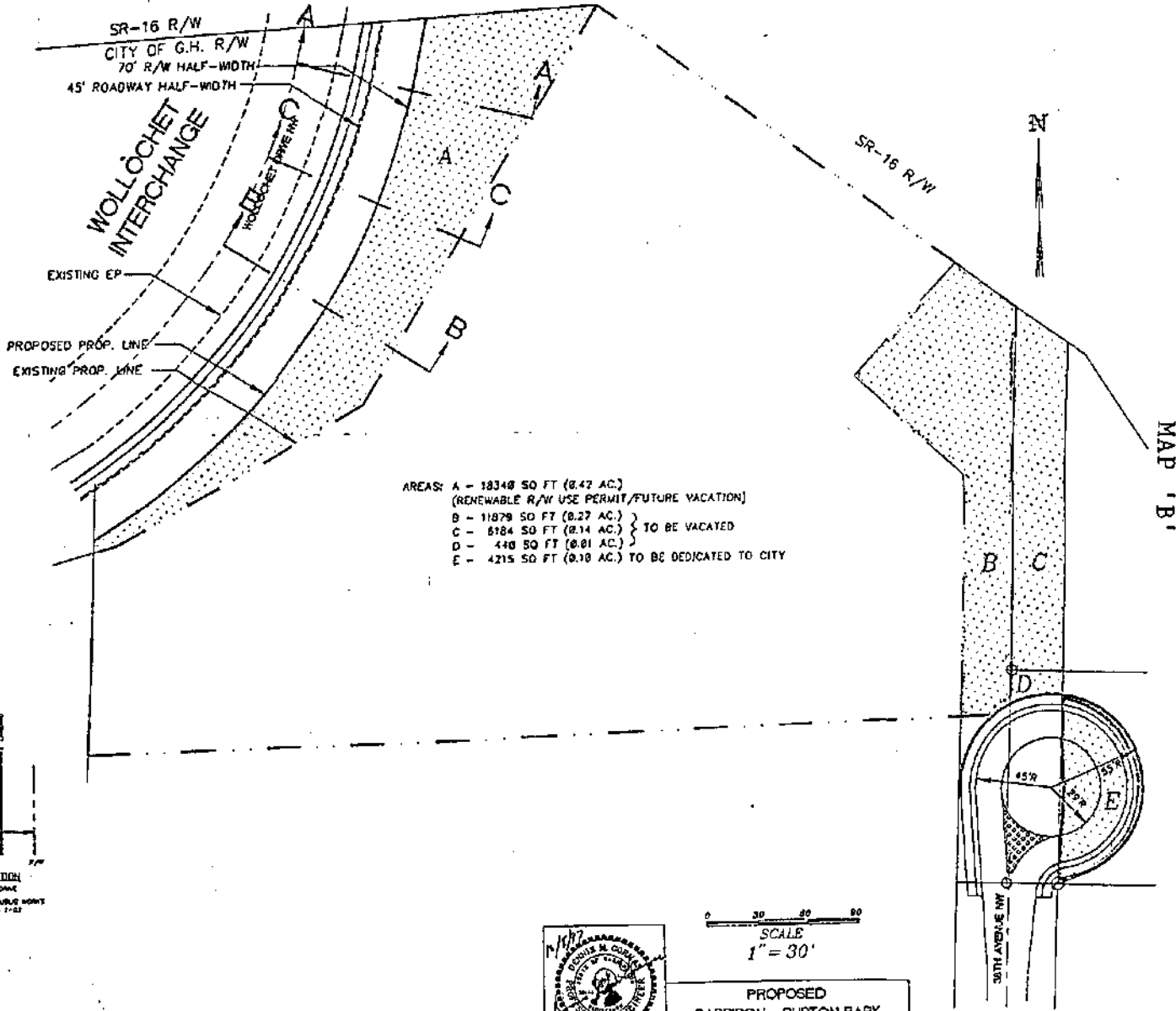
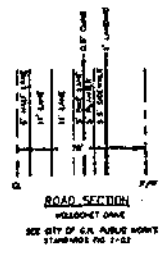

- AREAS: A - 18348 SQ FT (0.42 AC.)  
 (RENEWABLE R/W USE PERMIT/FUTURE VACATION)  
 B - 11879 SQ FT (0.27 AC.)  
 C - 6184 SQ FT (0.14 AC.) } TO BE VACATED  
 D - 448 SQ FT (0.01 AC.) }  
 E - 4215 SQ FT (0.10 AC.) TO BE DEDICATED TO CITY

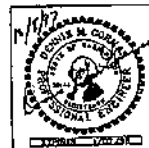

SCALE  
1" = 30'

PROPOSED  
GARRISON - BURTON PARK  
RIGHT OF WAY REVISION

OCT 8, 1997 EX-HBT SP 092497

MAP 'B'



A NATURAL RESOURCE CORPORATION

(206) 858-8444  
P.O. BOX 492, GIG HARBOR, WA 98335 (206) 858-8448 FAX

City of Gig Harbor  
3105 Judson Street  
Gig Harbor, WA 98335

Attention: City Clerk

September 12, 1997

#### PETITION FOR VACATION

Talmo, Inc. and Burton Park Associates, as the owners of real estate abutting city street right of way, is petitioning the Gig Harbor City Council to vacate parcels A, B, C, and D as shown on attached exhibit "SP091297". Also included as attachments are the legal descriptions of the above mentioned parcels as prepared by, Michael N. Sprouffske, SP-RO-UM-N596ND, a licensed surveyor.

This petition has been signed by all of the owners of the abutting properties. Please see attached exhibits "A", "B", "C", and "D".

Included is a \$ 150.00 prehearing fee to defray the administrative costs that will be incurred in processing this petition.

Talmo, Inc. And Burton Park Associates are aware that at such a time as the City Council recommends granting a vacation petition, \$ 500.00 shall be deposited with the public works director, which shall be the City's estimated cost of doing a full appraisal. In the event that the appraisal cost is less than the amount deposited, the vacation compensation payable to the City shall be reduced by the difference between the deposit and the actual cost. In the event the cost of the appraisal is more than the amount deposited, the vacation compensation payable to the City shall be increased by the difference between the deposit and the actual cost.

Compensation for the vacations shall be made in accordance with Section 12.14.018 of the Gig Harbor Municipal Code.

Talmo, Inc. is aware that the vacation ordinance will contain provisions requiring improvements be made to the City right of way on Wollochet Drive, abutting parcel A of exhibit "SP091297". These improvements will be done at such a time as Wollochet Drive is improved. All improvements will meet current design standards and codes.

Burton Park Associates is prepared to deed to the City, parcel E as seen on attached exhibit "SP091297", a portion of Pierce County Tax Parcel 0221083087. Please see the attached exhibit "E" and the attached legal description of parcel E prepared by our licensed surveyor. Burton Park Associates would like to include the value of parcel E in the final calculation of value of the vacation of parcels C and D. If possible, Burton Park Associates would like to take care of the vacations and the deed back all in the same process.

Please contact Scott Wagner at Talmo, Inc., 858-8444, with any questions or comments.



# Exhibit "A"

## Parcel A

Properties Abutting Parcel A: Pierce County Washington Tax Parcel 0221074052  
Owner Talmo, Inc.

Pierce County Washington Tax Parcel 0221078001  
Owner Talmo, Inc.

Pierce County Washington Tax Parcel 0221078002  
Owner Talmo, Inc.

DATED September 12, 1997

Talmo, Inc., A Washington Corporation

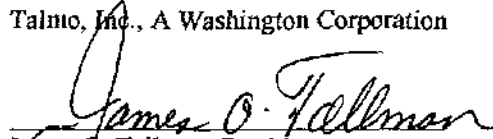
  
James O. Tallman, President

STATE OF WASHINGTON }  
COUNTY OF PIERCE }

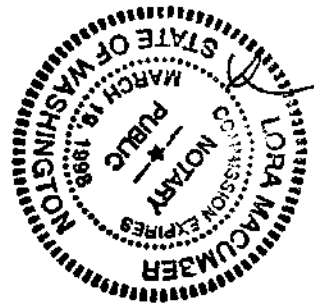

On September 24, 1997, before me the undersigned, a Notary Public in and for the State of Washington, duly commissioned and sworn, personally appeared James O. Tallman to me known to be the President of TALMO, INC., the corporation that executed the forgoing instrument, and acknowledged the instrument to be the free and voluntary act and deed of said corporation, for the uses and purposes therein mentioned, and on oath stated that he is authorized to execute the said instrument.

Witness my hand and official seal hereto affixed the day and year first written above.

  
Lora Macumber

Notary Public in and for the  
State of Washington, residing at Gig Harbor  
Commission expires 3/19/98

# Exhibit "B"

## Parcel B

Properties Abutting Parcel B: Pierce County Washington Tax Parcel 0221078003  
Owner Talmo, Inc.

Pierce County Washington Tax Parcel 0221078004  
Owner Talmo, Inc.

DATED September 12, 1997

Talmo, Inc., A Washington Corporation

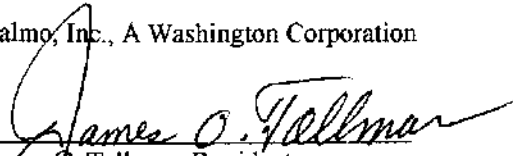
  
James O. Tallman, President

STATE OF WASHINGTON }  
COUNTY OF PIERCE }

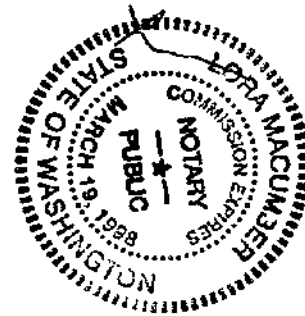

On September 24<sup>th</sup>, 1997, before me the undersigned, a Notary Public in and for the State of Washington, duly commissioned and sworn, personally appeared James O. Tallman to me known to be the President of TALMO, INC., the corporation that executed the forgoing instrument, and acknowledged the instrument to be the free and voluntary act and deed of said corporation, for the uses and purposes therein mentioned, and on oath stated that he is authorized to execute the said instrument.

Witness my hand and official seal hereto affixed the day and year first written above.

  
Lora Macumber  
Notary Public in and for the  
State of Washington, residing at Gig Harbor  
Commission expires 3/19/98

Exhibit "C"  
Parcel C

Properties Abutting Parcel C: Pierce County Washington Tax Parcel 0221083089  
Owner Burton Park Associates

DATED September 12, 1997

Burton Park Associates, A General Partnership

  
\_\_\_\_\_  
David R. Morris, Managing Partner

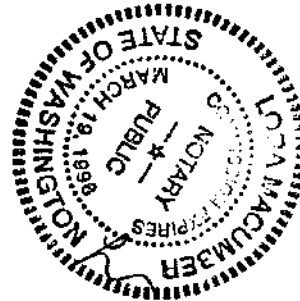

STATE OF WASHINGTON }  
COUNTY OF PIERCE }

On September 12, 1997, before me the undersigned, a Notary Public in and for the State of Washington, duly commissioned and sworn, personally appeared David R. Morris to me known to be the Managing Partner of Burton Park Associates, the general partnership that executed the forgoing instrument, and acknowledged the instrument to be the free and voluntary act and deed of said general partnership, for the uses and purposes therein mentioned, and on oath stated that he is authorized to execute the said instrument.

Witness my hand and official seal hereto affixed the day and year first written above.

  
\_\_\_\_\_  
Lora Macumber  
Notary Public in and for the  
State of Washington, residing at Gig Harbor  
Commission expires 3/19/98

# Exhibit "D"

## Parcel D

Properties Abutting Parcel D: Pierce County Washington Tax Parcel 0221083087  
Owner Burton Park Associates

DATED September 12, 1997

Burton Park Associates, A General Partnership

  
\_\_\_\_\_  
David R. Morris, Managing Partner

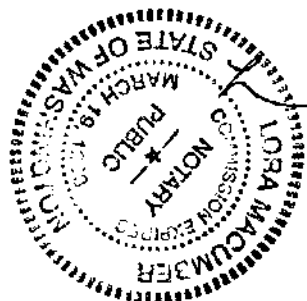

STATE OF WASHINGTON)  
COUNTY OF PIERCE}

On September 24<sup>th</sup>, 1997, before me the undersigned, a Notary Public in and for the State of Washington, duly commissioned and sworn, personally appeared David R. Morris to me known to be the Managing Partner of Burton Park Associates, the general partnership that executed the forgoing instrument, and acknowledged the instrument to be the free and voluntary act and deed of said general partnership, for the uses and purposes therein mentioned, and on oath stated that he is authorized to execute the said instrument.

Witness my hand and official seal hereto affixed the day and year first written above.

  
\_\_\_\_\_  
Lora Macumber  
Notary Public in and for the  
State of Washington, residing at Gig Harbor  
Commission expires 3/19/98



# Exhibit "E"

Parcel E

Property To Be Deeded, Parcel E, A Portion Of:

Pierce County Washington Tax Parcel 0221083087  
Owner Burton Park Associates

DATED September 12, 1997

Burton Park Associates, A General Partnership

  
\_\_\_\_\_  
David R. Morris, Managing Partner



STATE OF WASHINGTON }  
COUNTY OF PIERCE }

On September ~~24~~<sup>12</sup>, 1997, before me the undersigned, a Notary Public in and for the State of Washington, duly commissioned and sworn, personally appeared David R. Morris to me known to be the Managing Partner of Burton Park Associates, the general partnership that executed the forgoing instrument, and acknowledged the instrument to be the free and voluntary act and deed of said general partnership, for the uses and purposes therein mentioned, and on oath stated that he is authorized to execute the said instrument.

Witness my hand and official seal hereto affixed the day and year first written above.

  
\_\_\_\_\_  
Lora Macumber  
Notary Public in and for the  
State of Washington, residing at Gig Harbor  
Commission expires 3/19/98

**PARCEL A**

All that portion of the right-of-way of Wollochet Drive Northwest Conveyed to Pierce County by Governor's Deed dated January 29th, 1974 and recorded under Auditor's fee No. 2541145, which lies southerly and easterly of the following described line:

**Commencing** at the intersection of the West line of Lot 13 of Section 7, Township 21 North, Range 2 East, Willamette Meridian, of the Gig Harbor Abandoned Military Reserve with the A-3 line of Wollochet Drive Northwest, as shown on Sheet 9 of that certain Map of Definite Location entitled SR16, Narrows Bridge to Olympic Drive;  
thence along said A-3 line and the centerline of Wollochet Drive, N 66°04'39" E for 48.38 feet; to a curve whose station is 41+46.76, the radius point of which bears N 23°55'21" W, 350.00 feet;  
thence northeasterly along said curve through a central angle of 06°49'55", for 41.73 feet;  
thence S 30°45'16" E for 75.98 feet to the **POINT OF BEGINNING** of this described line  
thence returning N 30°45'16" W 5.98 feet to a curve, the radius point of which bears N 30°45'16" W, 420.00 feet;  
thence northeasterly along said curve through a central angle of 47°40'05", for 349.43 feet, more or less, to the Turnback Line as depicted on said Sheet 9 and the **terminus** of this described line.

PARCEL B

All that portion of the right-of-way of SR16 Conveyed to Pierce County by Governor's Deed dated January 29th, 1974 and recorded under Auditor's fee No. 2541145, and all that portion of 38th Street Northwest described as follows: Commencing at a point opposite Highway Engineer's Station BL-3 6+00 and 55 feet southwesterly therefrom, when measured at right angles and/or radially to the BL-3 line of SR16, MP 8.34 to MP 18.87, Narrows Bridge to Olympic Drive; thence northwesterly to a point opposite Highway Engineer's Station BL-3 2+00 and 100 feet southwesterly therefrom; thence returning southeasterly along the last course, hereinafter to be referred to as the "Turnback Line," to a point opposite Highway Engineer's station BL-3 4+85 , when measured at right angles and/or radially to the BL-3 line of said highway, and the **POINT OF BEGINNING** of this described tract;

thence to a point opposite Highway Engineer's Station BL-3 4+85 and 90 feet southwesterly from the point of beginning; thence turning an angle of 90 degrees and running southeasterly in a straight line to the westerly right-of-way line of the 38th Street Northwest, extended northerly; thence southerly along said westerly right-of-way to a point 860 feet north of the section corner common to sections 7 and 8, T21N, R2E, said measurement along said section line and perpendicular to said section line; then easterly along said line to the section line; then northerly along said section line to the Turnback line; thence northwesterly along said Turnback line to the point of beginning.

**EXCEPT** any portion which lies within a circle with a radius of 50 feet whose center is 819.69 feet northerly, as measured along the section line, of the section corner common to sections 7 and 8 of T21N, R2E, W.M., and 24.72 feet easterly of said section line, measured perpendicular to said section line

**PARCEL C**

All that portion of the following described tract which lies within section 8, Township 21 North, Range 2 East, Willamette Meridian;

All that portion of the right-of-way of SR16 Conveyed to Pierce County by Governor's Deed dated January 29th, 1974 and recorded under Auditor's fee No. 2541145, described as follows: Commencing at a point opposite Highway Engineer's Station BL-3 6+00 and 55 feet southwesterly therefrom, when measured at right angles and/or radially to the BL-3 line of SR16, MP 8.34 to MP 18.87, Narrows Bridge to Olympic Drive; thence northwesterly to a point opposite Highway Engineer's Station BL-3 2+00 and 100 feet southwesterly therefrom; thence returning southeasterly along the last course, hereinafter to be referred to as the "Turnback Line," to a point opposite Highway Engineer's station BL-3 4+85 , when measured at right angles and/or radially to the BL-3 line of said highway, and the **POINT OF BEGINNING** of this described tract;

thence to a point opposite Highway Engineer's Station BL-3 4+85 and 90 feet southwesterly from the point of beginning; thence turning an angle of 90 degrees and running southeasterly in a straight line to the westerly right-of-way line of the 38th Street Northwest, extended northerly; thence southerly along said westerly right-of-way to a point 860 feet north of the section corner common to sections 7 and 8, T21N, R2E, said measurement along said section line and perpendicular to said section line; then easterly along said line to the easterly right-of-way line of 38th Street Northwest; then northerly along said right-of-way line to the Turnback line; thence northwesterly along said Turnback line to the point of beginning.

**EXCEPT** the south 27.70 feet thereof.

PARCEL D

The south 27.70 feet of the following described tract:

All that portion of the following described tract which lies within section 8, Township 21 North, Range 2 East, Willamette Meridian;

All that portion of the right-of-way of SR16 Conveyed to Pierce County by Governor's Deed dated January 29th, 1974 and recorded under Auditor's fee No. 2541145, described as follows: Commencing at a point opposite Highway Engineer's Station BL-3 6+00 and 55 feet southwesterly therefrom, when measured at right angles and/or radially to the BL-3 line of SR16, MP 8.34 to MP 18.87, Narrows Bridge to Olympic Drive; thence northwesterly to a point opposite Highway Engineer's Station BL-3 2+00 and 100 feet southwesterly therefrom; thence returning southeasterly along the last course, hereinafter to be referred to as the "Turnback Line," to a point opposite Highway Engineer's station BL-3 4+85, when measured at right angles and/or radially to the BL-3 line of said highway, and the **POINT OF BEGINNING** of this described tract;

thence to a point opposite Highway Engineer's Station BL-3 4+85 and 90 feet southwesterly from the point of beginning; thence turning an angle of 90 degrees and running southeasterly in a straight line to the westerly right-of-way line of the 38th Street Northwest, extended northerly; thence southerly along said westerly right-of-way to a point 860 feet north of the section corner common to sections 7 and 8, T21N, R2E, said measurement along said section line and perpendicular to said section line; then easterly along said line to the easterly right-of-way line of 38th Street Northwest; then northerly along said right-of-way line to the Turnback line; thence northwesterly along said Turnback line to the point of beginning.

**EXCEPT** any portion which lies within a circle with a radius of 50 feet whose center is 819.69 feet northerly, as measured along the section line, of the section corner common to sections 7 and 8 of T21N, R2E, W.M., and 24.72 feet easterly of said section line, measured perpendicular to said section line

**PARCEL E**

All that portion of the following described tract which lies within a circle with a radius of 50 feet whose center is 819.69 feet northerly, as measured along the section line, of the section corner common to sections 7 and 8 of T21N, R2E, W.M., and 24.72 feet easterly of said section line, measured perpendicular to said section line:

The west 60 feet of the north 125.34 feet of the south 225.34 feet of Lot 8 of Gig Harbor Abandoned Military Reserve in Section 8, T21N R2E



*City of Gig Harbor. The "Maritime City."*

3105 JUDSON STREET  
GIG HARBOR, WASHINGTON 98335  
(253) 851-8136

**TO: MAYOR WILBERT AND CITY COUNCIL**  
**FROM: MARK HOPPEN, CITY ADMINISTRATOR** *MMA*  
**SUBJECT: First Reading of Ordinance - PART-TIME PERSONNEL BENEFITS**  
**DATE: SEPTEMBER 29, 1997**

#### **INFORMATION/BACKGROUND**

The attached ordinance responds to Council's direction at the last meeting to provide regulation with respect to benefits for employees who work part-time. This policy has been reviewed and approved by Legal Counsel.

#### **POLICY CONSIDERATIONS**

This ordinance allows employees who work part-time to receive benefits by paying a pre-determined share of benefits costs based on the number of hours worked per week, as averaged throughout a quarter year. Temporary employees are not eligible for benefits. Employees working less-than-20 hours per week are not eligible for benefits. Employees working from 20 up to 30 hours per week may purchase all benefits at 50% of benefits cost. Employees working from 30 up to 40 hours per week may purchase all benefits by paying 25% of benefits cost. Regular employees working 40 hours or more receive full benefits. Again, these proportions are determined on quarterly averages.

#### **FISCAL CONSIDERATIONS**

The city employs few part-time employees. Thus, the current fiscal ramifications of this policy are not particularly significant. This policy, however, clarifies these situations.

#### **RECOMMENDATION**

Staff recommends approval of the ordinance at the second reading.

ORDINANCE NO. \_\_\_\_\_

**AN ORDINANCE OF THE CITY OF GIG HARBOR, WASHINGTON,  
ESTABLISHING CRITERIA FOR ELIGIBILITY IN THE CITY'S HEALTH,  
VISION, DENTAL AND OTHER PAYROLL DEDUCTION PLANS AND  
FIXING A TIME WHEN THE SAME SHALL BECOME EFFECTIVE.**

---

WHEREAS, from time to time the City employs persons working part time or other alternative work schedules; and

WHEREAS, the City Council finds it to be in the public interest to establish rules for participation which would allow part time employees to receive benefits commensurate with the services they provide in order to maximize the use of public funds while permitting employees working lesser numbers of hours the protections and advantages of being involved in group health insurance plans and other benefit programs, NOW, THEREFORE

BE IT ORDAINED by the City Council of the City of Gig Harbor, Washington as follows:

Section 1. Regular employees of the City who, on a quarterly basis, work an average of less than the forty hour per week for weekly employees, or a proportionately adjusted number of hours for shift employees shall be eligible for participation in the City's benefit programs under the following terms and conditions:

- A. Employees working less than 20 hours per week shall not be eligible and may not participate in the City's benefit programs.
- B. Employees working from 20 up to 30 hours per week on a quarterly basis shall be eligible for participation in the benefit program by paying 50% benefit programs costs attributable to themselves and/or their families with the City paying the remaining 50% of the benefit program costs.
- C. Employees working from 30 up to 40 hours per week on a quarterly basis shall be eligible for participation in the benefit program by paying 25% of benefit program costs attributable to themselves and/or their families with the City paying the remaining 75% of the benefit program costs.
- D. Employees working 40 hours or more per week shall receive full benefits.



Section 2. As used herein, the following terms shall be given the definition shown:

- A. **Benefit Program.** Health, Vision, and Dental and other benefit programs, provided to regular full time employees of the City.
- B. **Program Costs.** The cost which the City pays on behalf of its full time employees.
- C. **Full Time Employee.** An employee working an average of 40 hours or more per week on a monthly basis, provided, however, that shift employees such as police officers who work a schedule calculated at greater than 40 hours per week shall have their eligibility determined on a proportionate basis by comparing the shift-worker's weekly work schedule with 40 hours per week.
- D. **Eligibility.** A part time employee shall be eligible for participation in the program after completing one full calendar quarter (3 months). A full time employee shall be eligible for participation in the program on the first day of the month following the date of employment.

Section 3. The benefits established pursuant to this program shall be interpreted and applied in accordance with the plan, requirements or insurance policy of a particular benefit program. For example, if the City has a program such as deferred compensation which the employee designates a portion of his or her salary, and the City has no cost, an employee may participate regardless of the number of hours, the provisions of the program shall apply. In the event of conflict with any individual employment contract or labor collective bargaining agreement, the provisions of the contract or the collective bargaining agreement shall control.

Section 4. Severability. If any section, subsection, paragraph, sentence, clause or phrase of this ordinance is declared unconstitutional or invalid for any reason, such invalidity shall not affect the validity or effectiveness of the remaining portions of this ordinance.

Section 5. Effective Date. This ordinance shall take effect and be in full force and effect five (5) days after its passage, approval and publication as required by law.

PASSED by the City Council of the City of Gig Harbor, this \_\_\_\_ day of October, 1997.

APPROVED:

---

Gretchen A. Wilbert, Mayor

ATTEST:

---

Molly M. Towslee, City Clerk

File with City Clerk: 9/30/97  
Passed by City Council:  
Date Published:  
Date Effective:

**SUMMARY OF ORDINANCE NO. \_\_\_\_\_  
of the City of Gig Harbor, Washington**

On \_\_\_\_\_, 1997, the City Council of the City of Gig Harbor, Washington, approved Ordinance No. \_\_\_\_\_, the summary of text of which is as follows:

**AN ORDINANCE OF THE CITY OF GIG HARBOR, WASHINGTON,  
ESTABLISHING CRITERIA FOR ELIGIBILITY IN THE CITY'S HEALTH,  
VISION, DENTAL AND OTHER PAYROLL DEDUCTION PLANS AND  
FIXING A TIME WHEN THE SAME SHALL BECOME EFFECTIVE.**

BE IT ORDAINED BY THE CITY COUNCIL OF THE CITY OF GIG HARBOR:

The full text of this ordinance will be mailed upon request.

APPROVED by the City Council at their regular meeting of \_\_\_\_\_, 1997.

BY: \_\_\_\_\_  
Molly M. Towslee, City Clerk





*City of Gig Harbor. The "Maritime City"*

DEPARTMENT OF PLANNING & BUILDING SERVICES  
3125 JUDSON STREET  
GIG HARBOR, WASHINGTON 98335  
(253) 851-4278

**TO: MAYOR WILBERT AND CITY COUNCIL MEMBERS**  
**FROM: PLANNING STAFF**  
**SUBJECT: SUB 94-01 (PUD) -- Rod Nilsson - Planned unit development consisting of 14 residential condominiums at 7502 Pioneer Way - Extension Request**  
**DATE: OCTOBER 13, 1997**

### **INTRODUCTION/BACKGROUND**

The Chapel Hill Townhomes received PUD approval by the Council on October 24, 1994, as per Resolution # 431 (copy attached). Condition #7 of the resolution stipulated the following:

Pursuant to GHMC section 17.90.060.[B], within three (3) years of the preliminary approval date, the applicant shall file with the City Council a final development plan in the form of a final condominium plat for the PUD which contains the information required in the preliminary plan including a 40-foot wide right-of-way dedicated to the City. Prior to or in conjunction with the final plat approval, the PUD portion of the site (as illustrated) and the single family residence portion of the site (fronting on Pioneer Way) shall be formally short platted as separate parcels.

The section of the zoning code referenced in this requirement (17.90.060[B]) was amended in March 1997 to allow a five-year period for completing the development plans. However, because the three-year deadline was stipulated in the resolution approving the Chapel Hill PUD, the five-year deadline cannot be assumed without an amendment.

### **POLICY CONSIDERATIONS**

The current code stipulates that PUD decisions shall be rendered by the Hearing Examiner rather than the City Council. However, this project was approved by the City Council by Resolution prior to adoption of the current PUD review standards. Amendments to the Resolution granting approval of this project must therefore be approved by the City Council.

### **FINDINGS AND RECOMMENDATION**

The staff finds that the project is well underway and that there have been no substantive changes in policies which would affect or alter the final design of this project. The staff therefore recommends approval of the requested amendment to apply the five year time limit on the completion of the development plan, as stipulated in GHMC Section 17.90.060(B). The staff has prepared a draft resolution approving the requested amendment for the Council's consideration.

**CITY OF GIG HARBOR  
RESOLUTION NO. \_\_\_\_**

**RESOLUTION OF THE CITY COUNCIL OF THE CITY OF GIG HARBOR,  
WASHINGTON, RELATING TO THE FINDINGS, CONCLUSIONS AND  
DECISION OF THE CITY COUNCIL ON THE APPLICATION FOR AN  
AMENDMENT TO SUB 94-01 (PUD) ALLOWING A TIME EXTENSION TO  
REFLECT CURRENT CODE REQUIREMENTS.**

---

**WHEREAS**, GHMC Section 17.90 defines review procedures for planned unit developments (PUD's).

**WHEREAS**, the City Council granted Mr. Rod Nilsson approval on October 24, 1994 for a PUD condominium project located at 7502 Pioneer Way as per Resolution # 431; and,

**WHEREAS**, Mr. Nilsson has requested an amendment to his PUD approval allowing application of current code deadlines for PUD development plans as stipulated in GHMC Section 17.90.060(B); and,

**WHEREAS**, the Planning Department for the City of Gig Harbor has recommended approval of the requested PUD amendment allowing application of current code deadlines for PUD development plans, in a staff report dated October 13, 1997, which states the staff's findings that there have been no substantive changes in policies which would affect or alter the final design of the previously approved PUD; and,

**WHEREAS**, the City Council agrees with the findings of the Planning Staff and adopts them herein by reference;

**NOW, THEREFORE, BE IT RESOLVED** by the City Council of the City of Gig Harbor, Washington, as follows:

That the Chapel Hill Planned Unit Development, as approved by Resolution #431, is hereby amended to allow current code deadlines for submittal of PUD development plans as stipulated in GHMC Section 17.90.060(B), which establishes a new deadline of October 24, 1999.

**PASSED** by the City Council of the City of Gig Harbor, Washington, and approved by its Mayor at a regular meeting of the Council held on this 13<sup>th</sup> day of October, 1997.

---

Gretchen A. Wilbert, Mayor

ATTEST:

---

Mark E. Hoppen  
City Administrator/Clerk

Filed with City Clerk: 10/8/97  
Passed by City Council: 10/13/97

**CITY OF GIG HARBOR  
RESOLUTION NO. 431**

**WHEREAS**, Rod Nilsson of Rikson Development has requested approval for a planned unit development (PUD) for the construction of 14 residential units at 7502 Pioneer Way; and,

**WHEREAS**, the Gig Harbor City Council has adopted guidelines for the reviewing of planned unit developments as outlined in GHMC section 17.90; and,

**WHEREAS**, the Planning Department for the City of Gig Harbor has recommended conditional approval of the PUD, in a staff report dated September 21, 1994; and

**WHEREAS**, the City of Gig Harbor Hearing Examiner conducted a public hearing on the application on September 21, 1994 to accept public comment on; and,

**WHEREAS**, the City of Gig Harbor Hearing Examiner has made specific findings and conclusions and has recommended conditional approval of said PUD in his report dated October 5, 1994; and,

**WHEREAS**, the City Council, during its regular meeting of October 24, 1994 reviewed the proposed PUD and the findings and recommendation of the Hearing Examiner; and,

**WHEREAS**, the City Council has determined that the PUD and the recommendation of the Hearing Examiner to be consistent with City codes and policies regulating Planned Unit Developments; and

**WHEREAS**, the City Council has determined that the development would provide significant public benefits including the dedication and improvement of a public road, an alternative housing choice in the downtown area, and a design which preserves and enhances the architectural character of the downtown/Millville area, in exchange for the increased density and other code exceptions as defined on the site plan and elevation drawings;

**NOW, THEREFORE, BE IT RESOLVED** by the City Council of the City of Gig Harbor, Washington, as follows:

That the findings, conclusions and recommendations of the Hearing Examiner in his report dated October 5, 1994 are hereby adopted and the Planned Unit Development is approved subject to the following conditions:

1. Fire flow must be provided to within 300 FT of the front entrance to each parcel and within 150 FT of each portion of each tri-plex in accordance with the Section 10.401, 1991 Uniform Fire Code. The minimum fire hydrant spacing on Edwards is at each street intersection, at the entrance to the PUD and every 600 FT.
2. Fire flow must be provided to the building in accordance with the Section 10.401, 1991 Uniform Fire Code (Appendix III-A & B) or as required by the Uniform Fire Code as adopted by the City of Gig Harbor.



3. An auto-fire sprinkler system must be included in the tri-plexes if the entire structure exceeds 5000 square feet in area.
4. The sidewalks must match the existing sidewalks on Edwards Drive which include 5'-6" sidewalk width and a 6" curb width as per Public Works Department standards.
5. Utility locations must be reviewed upon submittal of construction plans.
6. A 6-foot privacy fence shall be installed along the Coho Street frontage behind units 9 through 14; along the 66 foot portion of the eastern property boundary beside unit 1; and along the portion of the eastern property between unit 14 and the Benum property.
7. Pursuant to GHMC section 17.90.060.C, within three (3) years of the preliminary approval date, the applicant shall file with the City Council a final development plan in the form of a final condominium plat for the PUD which contains the information required in the preliminary plan including a 40-foot wide right-of-way dedicated to the City. Prior to or in conjunction with the final plat approval, the PUD portion of the site (as illustrated) and the single family residence portion of the site (fronting on Pioneer Way) shall be formally short platted as separate parcels.
8. Maintenance of all privately owned common facilities within the PUD, including fences along the periphery of the PUD, shall be the responsibility of the developer or a home owners association. If common facilities are to be maintained by a home owners association, the association shall be established and incorporated prior to final plat approval. A copy of the association's bylaws shall be submitted with the final plat and shall include, at a minimum, the following authorities and responsibilities:
  - A. The enforcement of covenants imposed by the landowner or developer.
  - B. The levying and collection of assessments against all lots to accomplish the association's responsibilities.
  - C. The collection of delinquent assessments through the courts.
  - D. The letting of contracts to build, maintain and manage common facilities.
9. A final landscaping plan for the common areas within the plat shall be submitted to the Planning Department prior to finalization of the plat. The plan shall comply with the provisions of Section 17.78.080 of the Gig Harbor Zoning Code along the eastern portion of the subject property between the Lentz property and parking/circulation area of the proposed project. The plan shall also make provisions for a triangular shaped landscape area in the center of the common court. Said landscape area shall be the maximum possible size while still allowing for convenient and safe vehicular and fire access. The plan shall include provisions for a mechanical irrigation system. Landscaping shall be installed prior to final occupancy of last three units.

10. In lieu of construction of required improvements prior to final plat approval, a bond equal to an amount of 130% of the contractors bid for all improvements required under the preliminary plat approval shall be posted with the City. If accepted by the City, the bond shall have a term not to exceed eighteen (18) months from the filing of the plat with the Pierce County auditor. Required improvements shall be installed within twelve months of the date of the filing of the plat. Failure to construct or install the required improvements within the time specified to City standards shall result in the City's foreclosure of the bond. Upon foreclosure, the City shall construct, or may contract to construct and complete, the installation of the required improvements.
11. Prior to permit issuance, the applicant shall submit to the Staff a final color palette which shall provide modest variation from unit to unit in order to emphasize the individuality of each unit and maintain the character of the single family neighborhood. To allow buyers choices of colors, the color palette does not have to be unit-specific, provided that contiguous units are not the same color.
12. Prior to building permit issuance a grading and drainage plan, including provisions for storm water collection and retention, shall be submitted to the Public Works Department for review and approval.
13. The pavement on Edwards Street in this portion be increased from 25 to 28 feet to allow for an eight foot parking lane and two ten foot lanes.
14. The applicant may execute a voluntary agreement with the City of Gig Harbor within the next 60 days to provide a left turn lane at the intersection of Pioneer way and the new street.

**PASSED** by the City Council of the City of Gig Harbor, Washington, and approved by its Mayor at a regular meeting of the Council held on this 24th day of October, 1994.

  
Gretchen A. Wilbert, Mayor

ATTEST:

  
Mark E. Hoppen  
City Administrator/Clerk

Filed with City Clerk: 10/14/94  
Passed by City Council: 10/24/94



City of Gig Harbor. The "Maritime City."

3105 JUDSON STREET  
GIG HARBOR, WASHINGTON 98335  
(253) 851-8136

**TO: MAYOR WILBERT AND CITY COUNCIL MEMBERS**  
**FROM: WES HILL, P.E., PUBLIC WORKS DIRECTOR** *Wes Hill*  
**SUBJECT: UNDERGROUND STORAGE TANK REMOVAL – CONTRACT AWARD**  
**DATE: OCTOBER 8, 1997**

### INTRODUCTION/BACKGROUND

In 1987, the City installed two, 1,000-gallon fuel storage tanks at the City Shop. The tanks conformed with the Underground Storage Tank (UST) regulations in effect at that time. In the interim, more stringent requirements have become effective, including insurance provisions (\$1,000,000 coverage for UST's at \$2,000 per year plus initial soils testing at approximately \$3,500 to obtain the insurance), additional monitoring and testing (e.g., annual tank tightness testing at \$500/year), and an annual licensing fee (\$150/year). For these reasons, the tanks have essentially been out of service for the past three years, with the only use being during last winter's power outage when fuel was not available at the commercial fuel outlet. The Department of Ecology has advised this Department that the two underground storage tanks must be removed, or the fueling system upgraded to conform with current regulations.

Considering the additional costs to upgrade system, annual compliance, the limited usage, and viable fueling alternatives, this Department has obtained price quotations for decommissioning and removal of the two fuel tanks in accordance with the City's Small Works Roster procedures. Four price quotations were received, and are summarized below:

<u>Contractor</u>	<u>Price Quotation</u>
Kleen Environmental Technologies, Inc.	\$8,051.40
Don Golden Company, Inc.	\$8,841.42
Clean Service Company	\$8,974.80
Gecon Corporation	\$9,720.00

The lowest price quotation received was from Kleen Environmental Technologies, Inc., in the corrected amount of \$8,051.40, including sales tax (\$0.40 discrepancy in computed sales tax). As can be seen from the price quotations, there was excellent competition for the work. It is anticipated that the work will be completed within four weeks after contract award, weather permitting.

### ISSUES/FISCAL IMPACT

Funds are available for this work.

### RECOMMENDATION

Staff recommends that Council move and approve award and execution of the contract for the decommissioning and removal of the underground storage fuel storage tanks at the City shop to Kleen Environmental Technologies, Inc., as the lowest responsible respondent, for their corrected

**MAYOR WILBERT AND CITY COUNCIL**

**October 8, 1997**

**Page 2**

price quotation proposal amount of eight-thousand fifty-one dollars and forty cents (\$8,051.40), including sales tax, subject to their compliance with the contract provisions.



*City of Gig Harbor. The "Maritime City."*

3105 JUDSON STREET  
GIG HARBOR, WASHINGTON 98335  
(253) 851-8136

**TO: MAYOR WILBERT AND CITY COUNCIL**  
**FROM: MOLLY TOWSLEE, CITY CLERK**  
**SUBJECT: CONSOLIDATION OF COPIER MAINTENANCE CONTRACTS**  
**DATE: OCTOBER 1, 1997**

#### **INFORMATION/BACKGROUND**

Last month, Council approved the renewal of the annual maintenance contract for the copier in the Planning Department. A few days later, the renewal notice arrived for the copier upstairs at City Hall. Rather than bringing four separate contracts for approval on a yearly basis, Minolta was asked to consolidate all four machines onto one maintenance contract with a monthly billing. This contract will include all labor and supplies (except paper and staples), and will utilize the State contract amount of .0115 per copy.

#### **FISCAL IMPACTS**

The 20,000 copies per month for all four machines amount was chosen by averaging the use over the past few months. The actual usage during the month of September was 26,927 copies. The figure of 20,000 may be on the low side, but any overages will be charged at the same State contract rate of .0115 as the base contract. It is more prudent to contract at the lower rate and pay overages than to choose a higher amount and pay the contract amount even though you do not actually use the copies.

The first billing will include the overages from the two expired contracts from the Planning Department machine and the upstairs City Hall machine.

#### **RECOMMENDATION**

Move to authorize the Mayor to sign the attached consolidated copier service contract in the amount of \$230.00 per month and any copies over the 20,000 would be billed at the .0115 State contract amount.



# SUPPLY/SERVICE CONTRACT

RETURN THIS ENTIRE CONTRACT AND PAYMENT TO:  
MINOLTA BUSINESS SYSTEMS, INC.

Attention Tara Dahl  
Address 1300 Southcenter Blvd #110  
City/State/Zip Tukwila, WA 98188

Account Number 7201421

BILL TO:  
Company City of Gig Harbor  
Attention Molly  
Address 3105 Judson St.  
City/State/Zip Gig Harbor, WA 98335  
Phone 857-8136

SHIP TO:  
Company \_\_\_\_\_  
Attention \_\_\_\_\_  
Address \_\_\_\_\_  
City/State/Zip \_\_\_\_\_  
Phone \_\_\_\_\_

Commencement Meter \_\_\_\_\_

Commencement Date \_\_\_\_\_

Model Aggr: Serial # Aggr:

M/A Meter Expiration \_\_\_\_\_

Comments This includes 4 minolta copiers

### TERMS AND CONDITIONS

CHECK ONE:

ANNUAL CONTRACT for a period of one year or \_\_\_\_\_ copies, whichever comes first.

ANNUAL CONTRACT billed monthly, for a period of one year, based upon minimum monthly volume of 20,000 copies (not less than 10,000) at a charge of -.0115 per copy.

This contract includes all labor, supplies (based upon published yields) as specified below, parts, and photoconductor (drum); excludes paper and staples.

INC bottles/cartridges of black toner INC bottles of black starter.

Comments: This Contract will cover the following machines: EP6000 SN# 3112948  
EP6000 SN# 3113093, EP4233 SN# 312885  
EP3050 SN# 312885

### AMOUNT DUE

SUBTOTAL \$310.00

SALES TAX Billed Monthly

TOTAL DUE \_\_\_\_\_

S/R \_\_\_\_\_  
S.O. # \_\_\_\_\_

by \_\_\_\_\_ DATE \_\_\_\_\_  
CUSTOMER SIGNATURE

by \_\_\_\_\_ DATE \_\_\_\_\_  
MBS CREDIT MANAGER

Title \_\_\_\_\_

by \_\_\_\_\_ DATE \_\_\_\_\_  
MBS SERVICE MANAGER

When this Agreement is signed by the Customer and the Branch Service Manager, it shall constitute a binding Agreement.

See Reverse Side for Additional Terms and Conditions.

SSC1/88



RETURN TO: WASHINGTON STATE LIQUOR CONTROL BOARD  
 License Division - 1025 E. Union, P.O. Box 43075  
 Olympia, WA 98504-3075  
 (360) 664-0012

TO: CITY OF GIG HARBOR

DATE: 9/30/97

AMENDED

RE: NEW APPLICATION

RECEIVED

OCT 1 - 1997

CITY OF GIG HARBOR

License: 080669 - 2E County: 27  
 Tradename: HARBOR HUMIDOR  
 Loc Addr: 313 56TH ST NW STE 5  
 GIG HARBOR WA 98335  
 Mail Addr: 3123 56TH ST NW STE 5  
 GIG HARBOR WA 98335-1363  
 Phone No.: 253-853-6372 CHRIS MARTIN

APPLICANTS:  
 HARBOR HUMIDOR INC.  
 ARENDS, KNEELAND REX 05-07-64 533-84-3476  
 MARTIN, CHRIS 11-28-63 538-82-5831

Classes Applied For:

- D Beer by open bottle only - on premises
- E Beer by bottle or package - off premises
- F Wine by bottle or package - off premises

As required by RCW 66.24.010(8), you are notified that application has been made to the Washington State Liquor Control Board for a license to conduct business. If return of this notice is not received in this office within 20 DAYS from the date above, it will be assumed that you have no objection to the issuance of the license. If additional time is required you must submit a written request for an extension of up to 20 days. An extension of more than 20 days will be approved only under extraordinary circumstances.

- |  | YES                      | NO                       |
|--|--------------------------|--------------------------|
| 1. Do you approve of applicant ? .....   | <input type="checkbox"/> | <input type="checkbox"/> |
| 2. Do you approve of location ? .....  | <input type="checkbox"/> | <input type="checkbox"/> |
| 3. If you disapprove and the Board contemplates issuing a license, do you want a hearing before final action is taken? ..... | <input type="checkbox"/> | <input type="checkbox"/> |

If you have indicated disapproval of the applicant, location or both, please submit a statement of all facts upon which such objections are based.

DATE

SIGNATURE OF MAYOR, CITY MANAGER, COUNTY COMMISSIONERS OR DESIGNEE

WASHINGTON STATE LIQUOR CONTROL BOARD-License Services  
1025 E Union - P O Box 43075  
Olympia WA 98504-3075

RECEIVED

OCT 1 - 1997

CITY OF GIG HARBOR

TO: MAYOR OF GIG HARBOR

September 30, 1997

SPECIAL OCCASION # 090826

CLASS: GJ

KNIGHTS OF COLUMBUS  
GIG HARBOR WA 98335

DATE: OCTOBER 26, 1997

TIME: NOON TO 6 PM

PLACE: ST. NICHOLAS CHURCH HALL, ROSEDALE ST., GIG HARBOR

CONTACT: JAMES WAINWRIGHT 253-857-4465

SPECIAL OCCASION LICENSES

- \* G    License to sell beer on a specified date for consumption at specific place.
- \* J    License to sell wine on a specific date for consumption at a specific place.  
   Wine in unopened bottle or package in limited quantity for off premises consumption.
- \* K    Spirituous liquor by the individual glass for consumption at a specific place.

If return of this notice is not received in this office within 20 days (10 days notice given for Class I) from the date above, we will assume you have no objection to the issuance of the license. If additional time is required please advise.

1. Do you approve of applicant? YES\_\_\_ NO\_\_\_
2. Do you approve of location? YES\_\_\_ NO\_\_\_
3. If you disapprove and the Board contemplates issuing a license, do you want a hearing before final action is taken? YES\_\_\_ NO\_\_\_

<u>OPTIONAL CHECK LIST</u>	<u>EXPLANATION</u>	
LAW ENFORCEMENT	_____	YES___ NO___
HEALTH & SANITATION	_____	YES___ NO___
FIRE, BUILDING, ZONING	_____	YES___ NO___
OTHER:	_____	YES___ NO___

If you have indicated disapproval of the applicant, location or both, please submit a statement of all facts upon which such objections are based.

---

DATE SIGNATURE OF MAYOR, CITY MANAGER, COUNTY COMMISSIONERS OR DESIGNER



C090080-2

WASHINGTON STATE LIQUOR CONTROL BOARD

DATE:10/03/97

LICENSED ESTABLISHMENTS IN INCORPORATED AREAS CITY OF GIG HARBOR  
FOR EXPIRATION DATE OF 12/31/97

LICENSEE	BUSINESS NAME AND ADDRESS	LICENSE NUMBER	CLASSES
1 BAYVIEW GROCERY AND DELI, INC.	BAYVIEW GROCERY AND DELI 8812 N HARBORVIEW DR GIG HARBOR WA 98335 0000	351392	E F
2 CUZZETTO, MICHAEL CUZZETTO, ROBERTA	GIG PUB AND GRILL 3226 HARBORVIEW DR GIG HARBOR WA 98332 0000	358890	H
3 OLYMPIC VILLAGE BP, INC.	OLYMPIC VILLAGE BP 5555 SOUNDVIEW DR NW GIG HARBOR WA 98335 0000	071544	E F

RECEIVED

OCT - 6 1997

CITY OF GIG HARBOR



RECEIVED

OCT 3 - 1997

CITY OF GIG HARBOR

STATE OF WASHINGTON

WASHINGTON STATE LIQUOR CONTROL BOARD

1025 E Union • PO Box 43075 • Olympia WA 98504-3075 • (360) 753-6262

October 1, 1997

Mayor of Gig Harbor

This is to notify you that:

THE CAPTAIN'S MATE, INC.  
7807 PIONEER WAY  
GIG HARBOR, WA 98335-1133

THE CAPTAIN'S KEEP  
7807 PIONEER WAY  
GIG HARBOR, WA 98335  
License No. 079385-2E  
UBI No. 601 493 563 001 0001

discontinued sales and service of liquor at the above location on  
September 30, 1997.

This is for your information and records.

LESTER C. DALRYMPLE, Supervisor  
Licensing Services

Connie Allsup, Support Specialist  
Licensing Support Unit  
360-664-8228

X095149

cc: 2E D. Harrison - Bremerton Office





**MITCH BARKER**  
Chief of Police

*City of Gig Harbor Police Dept.*  
3105 JUDSON STREET  
GIG HARBOR, WASHINGTON 98335  
(206) 851-2236

**TO: MAYOR WILBERT AND CITY COUNCIL**  
**FROM: MITCH BARKER, CHIEF OF POLICE**  
**SUBJECT: SEPTEMBER INFORMATION FROM PD**  
**DATE: OCTOBER 7, 1997**

Attached are the activity statistics for September 1997. As we discussed last month, we are seeing an increase in traffic infractions and DUI enforcement. This is due to three new officers on the road, and the resulting free time of their training officers.

The Explorers accounted for 60 hours of service in September. This time was split between two regular meetings, and providing traffic control at a PHS Boosters auction. Three new members joined the post in September.

The Reserves contributed 77 hours of service in September. We have had a hard time getting patrol car riding time for the Reserves due to the officers in training. With the cars freed up, they will be able to provide more service time in the coming months. We will be adding three new Reserve Officers in October.

The Marine Services Unit had 20 hours of service in September. Fifteen hours were spent on patrol with five for other duties. The boat will be pulled from the water for the season in October. It will be used for some scheduled events during the winter.

We have three new officers in the field on their own now. This leaves just off Douglas on active field training status. He is scheduled out on his own by early December.



MITCH BARKER  
Chief of Police

City of Gig Harbor Police Dept.  
3105 JUDSON STREET  
GIG HARBOR, WASHINGTON 98335  
(206) 851-2236

## GIG HARBOR POLICE DEPARTMENT

### MONTHLY ACTIVITY REPORT

#### September 1997

	<u>SEPT</u> <u>1997</u>	<u>YTD</u> <u>1997</u>	<u>YTD</u> <u>1996</u>	<u>%chg to</u> <u>1996</u>
CALLS FOR SERVICE	<u>329</u>	<u>2994</u>	<u>2344</u>	<u>+ 27</u>
CRIMINAL TRAFFIC	<u>19</u>	<u>129</u>	<u>118</u>	<u>+ 9</u>
TRAFFIC INFRACTIONS	<u>125</u>	<u>512</u>	<u>540</u>	<u>- 5</u>
DUI ARRESTS	<u>8</u>	<u>44</u>	<u>26</u>	<u>+ 69</u>
FELONY ARRESTS	<u>3</u>	<u>51</u>	<u>23</u>	<u>+ 121</u>
MISDEMEANOR ARRESTS	<u>7</u>	<u>110</u>	<u>126</u>	<u>- 12</u>
WARRANT ARRESTS	<u>7</u>	<u>40</u>	<u>48</u>	<u>- 16</u>
CASE REPORTS	<u>84</u>	<u>817</u>	<u>618</u>	<u>+ 32</u>
REPORTABLE VEHICLE ACCIDENTS	<u>11</u>	<u>109</u>	<u>71</u>	<u>+ 53</u>